

CARRIER PIPE (IN.)	MINIMUM O.D. CASING PIPE (IN.)
4	10
6	12
8	16
10	18
12	20
14	24
15	26
16	30
18	32
20	34
21	36
24	36
30	42

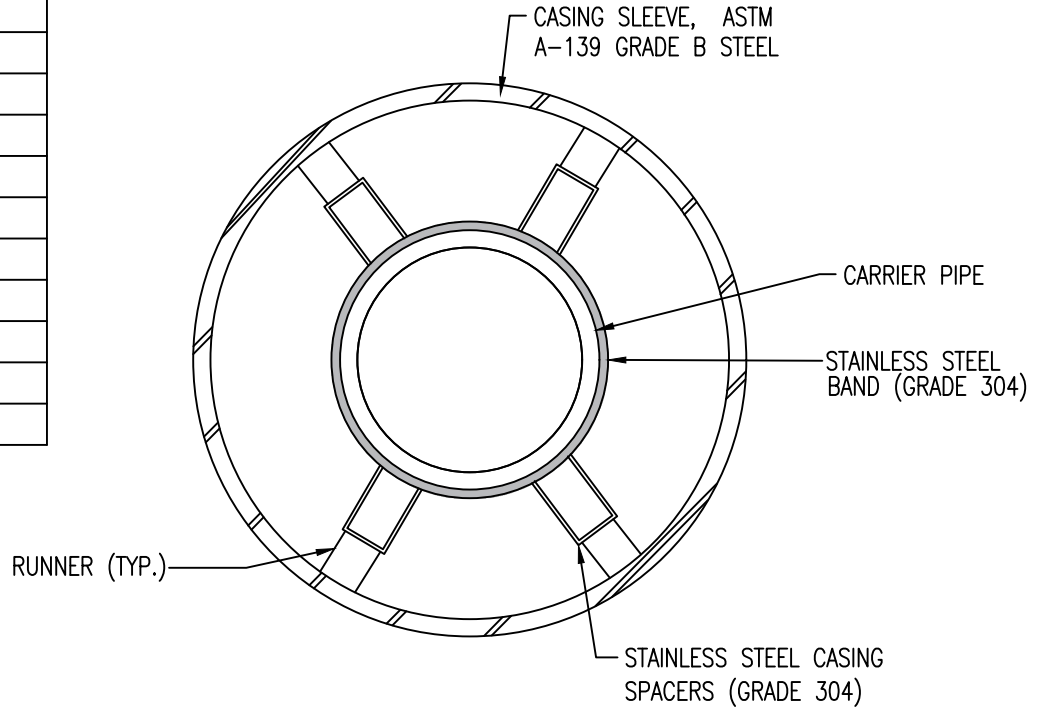

**NOTES:**

1. DETAIL APPLIES TO BOTH JACK AND BORE AND OPEN CUT INSTALLATIONS.
2. END SEAL SHALL BE INSTALLED ON EACH END OF CASING PIPE.
3. CASING SPACERS SHALL BE INSTALLED 1' (MAX.) FROM EACH SIDE OF ANY CARRIER PIPE JOINT, AND A MINIMUM OF 6' ON CENTER ALONG THE CARRIER PIPE IN BETWEEN JOINTS.
4. PREFERRED CONFIGURATION IS WITH CARRIER PIPE CENTERED WITHIN CASING PIPE. OFF-CENTERED CONFIGURATION MAY BE UTILIZED DEPENDING ON SITE CONDITIONS AS APPROVED BY THE COUNTY.
5. SEE TABLE ABOVE FOR MINIMUM CASING PIPE SIZE. IF RESTRAINED JOINTS ARE USED, CASING PIPE DIAMETER SHALL BE MODIFIED AS REQUIRED TO ACCOMMODATE THE PIPE RESTRAINTS.



SUSSEX COUNTY  
ENGINEERING DEPARTMENT

APPROVED: *[Signature]*  
SUSSEX COUNTY ENGINEER

**CASING SLEEVE  
INSTALLATION**

DETAIL  
S-3.03

DATE ISSUED:  
12/30/2021