

CONCRETE COLLAR (MIN. 4,000 PSI) AROUND ENTIRE PERIMETER OF MANHOLE FRAME AND COVER. CONCRETE COLLAR IS ONLY REQUIRED IF MANHOLE IS NOT IN PAVEMENT (SEE NOTE 6)

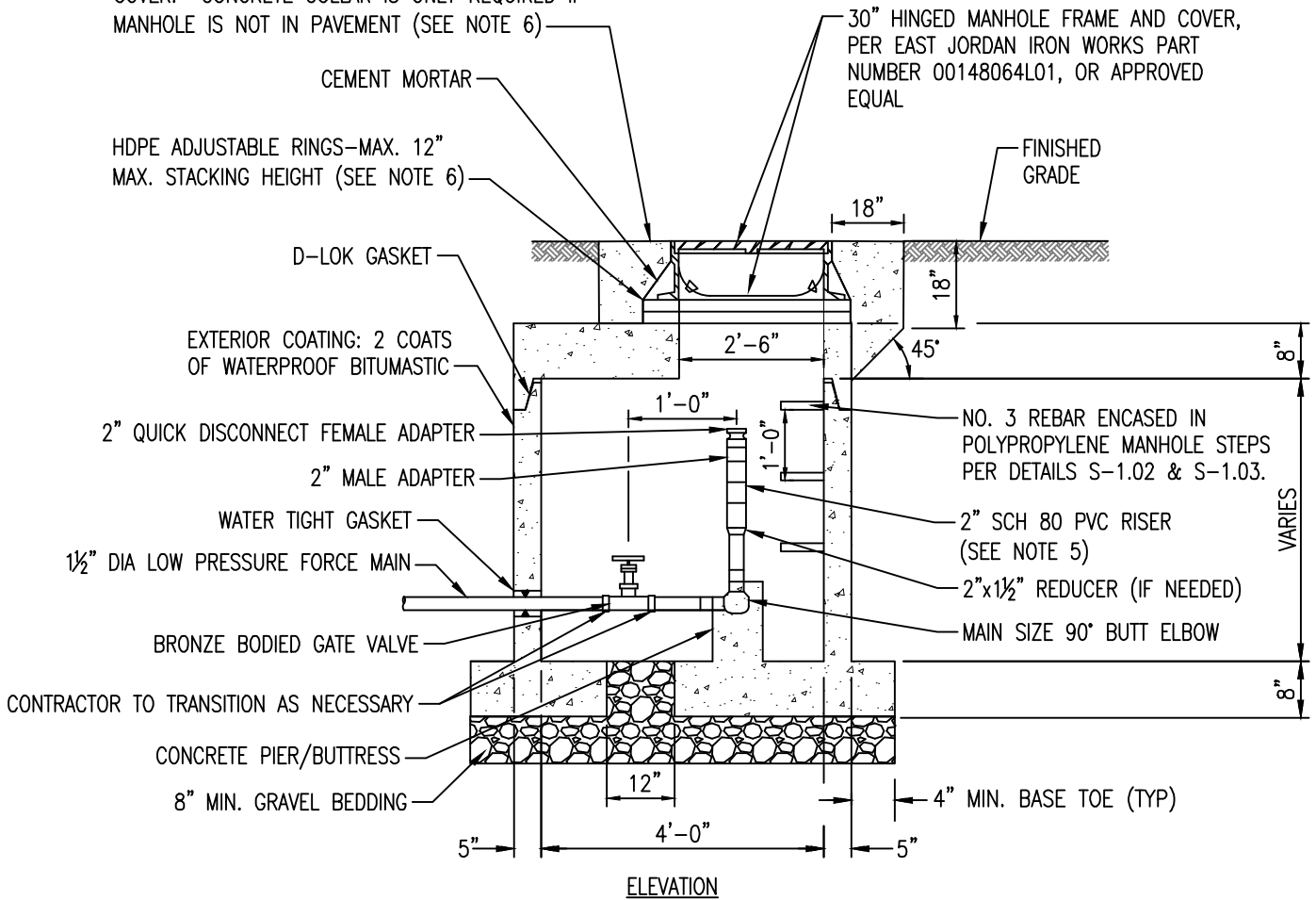

NOTES:

1. MANHOLE RISER SECTION SHALL CONFORM TO DETAIL S-1.01.
2. ALL CONNECTIONS WITHIN MANHOLE SHALL BE SOLVENT WELD OR THREADED.
3. ALL THREADED PIPE AND FITTINGS SHALL BE SCHEDULE 80 PVC.
4. PROVIDE GREEN COATED 12-GAUGE SOLID COPPER DETECTION WIRE TAPED TO TOP OF FORCE MAIN PIPE. PROVIDE 18" OF SLACK ABOVE TOP OF MANHOLE AND WRAP TO TOP MANHOLE STEP.
5. RISER PIPE SHALL BE Laterally SUPPORTED FROM MANHOLE WALLS.
6. FOR MANHOLE LOCATIONS IN DELDOT MAINTAINED ROADWAYS REFER TO CURRENT DELDOT REQUIREMENTS WITH RESPECT TO CONCRETE COLLAR PLACEMENT AND ALLOWABLE MATERIALS FOR GRADE ADJUSTMENT RINGS.
7. IF LOW PRESSURE SEWER MAIN IS DIFFERENT IN SIZE TO THAT SHOWN, PROVIDE THE APPROPRIATELY SIZED FITTINGS TO MAKE TRANSITIONS.
8. GROUT BOTTOM OF MANHOLE TO SLOPE TOWARD 12" DRAIN HOLE.

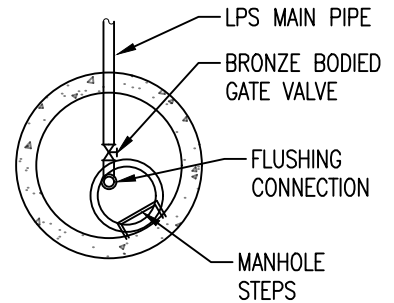

PLAN VIEW



SUSSEX COUNTY
ENGINEERING DEPARTMENT

APPROVED: *[Signature]*
SUSSEX COUNTY ENGINEER

**TERMINAL FLUSHING
CONNECTION**

DETAIL
S-5.05

DATE ISSUED:
09/09/2022