

COUNTY COUNCIL

MICHAEL H. VINCENT, PRESIDENT
JOHN L. RIELEY, VICE PRESIDENT
CYNTHIA C. GREEN
DOUGLAS B. HUDSON
MARK G. SCHAEFFER



Sussex County

DELAWARE
sussexcountye.gov
(302) 855-7743

SUSSEX COUNTY COUNCIL

AGENDA

October 29, 2024

12:30 P.M.

Call to Order

Approval of Agenda

Approval of Minutes - October 15, 2024

[Draft Minutes 101524](#)

Reading of Correspondence

Public Comments

Todd Lawson, County Administrator

1. **Recognition – Delaware Team Award of the Year**
2. **Recognition of Retiree – Raymond Alt**
3. **Administrator’s Report**

Gina Jennings, Finance Director

1. **Discussion and Possible Introduction of a Proposed Ordinance entitled “AN ORDINANCE TO AMEND CHAPTER 103, ARTICLE VI (“LODGING TAX”) OF THE CODE OF SUSSEX COUNTY TO INCLUDE THE IMPOSITION OF A LODGING TAX OF THREE PERCENT (3%) OF THE RENT FOR SHORT-TERM RENTALS IN THE UNINCORPORATED AREAS OF SUSSEX COUNTY IN ACCORDANCE WITH 9DEL. C.§ 8112(c) AND 30 DEL. C. § 6201”**

[Short Term Rental Proposed Ordinance](#)



Mike Harmer, County Engineer

1. **JP Court Annex, Project C25-06**
 - A. **Tevebaugh Architects – Expansion Feasibility Study**
[Tevebaugh Proposal](#)

Robert Bryant, Airport Manager

1. **Construct Parallel Taxiway B, Phase II, Project A24-15**
 - A. **Recommendation to Award**
 - B. **Delta Airport Consultants – Task Order 5**
[Construct Taxiway B](#)

Hans Medlarz, Project Engineer

1. **IBRWF – Loop Project, Project No. S24-01**
 - A. **Delmarva Power Agreement**
[IBRWF Loop Project DPL](#)
2. **South Coastal WRF Treatment Process Upgrade No.3 &**
 - A. **B.W. Electric – Change Order 28, Electrical Construction Project C19-17**
[SC CO No. 28](#)
3. **Approval of the revised Wastewater Service Agreement between the City of Seaford and the Unified Sanitary Sewer District**
[Revised Seaford County Agreement](#)

Grant Requests

1. **Greater Lewes Foundation for their Shaffer Foundation 4th Annual Rally for Responders**
[Greater Lewes Foundation](#)
2. **SODELO (Southern Delaware Orchestra) for their 2024 winter concerts**
[SODELO](#)
3. **Town of Georgetown for the Mayor’s Return Day reception**
[Town of Georgetown](#)
4. **Mariner Middle School (BPA) for their Business Professional of America program**
[Mariner Middle School \(BPA\)](#)
5. **Town of Greenwood for policing equipment**
[Town of Greenwood](#)
6. **Laurel Lions Club Foundation for a recreation complex**
[Laurel Lions Club Foundation](#)

7. **Grace-N-Mercy Ministries for their Thanksgiving community dinner**
[Grace N Mercy Ministries Inc](#)
8. **Bridgeville Public Library for a Mini-Library**
[Bridgeville Public Library](#)
9. **Cornerstone Community Center for their kids against tobacco program**
[Cornerstone Community Center](#)
10. **Town of Blades for their annual kids Christmas party**
[Town of Blades](#)
11. **Nanticoke Senior Center for an educational media center**
[Nanticoke Senior Center](#)
12. **Seaford Tomorrow for their Friday Night Live event**
[Seaford Tomorrow](#)
13. **First State Community Action Agency for their Anniversary Celebration**
[First State Community Action Agency](#)

Introduction of Proposed Zoning Ordinances

[Ord Intros CU2555 CU2520 CU2501 CU2458 CU2544](#)

Council Members' Comments

Executive Session - Land Acquisition pursuant to 29 Del.C.§10004(b)

Possible action on Executive Session Items

1:30 p.m. Public Hearings

1. **Leeward Chase II Annexation of the Sussex County Unified Sanitary Sewer District (Airpark Area)**
[Public Hearing Leeward Chase II](#)
2. **Woods at Agnola Beach Annexation of the Sussex County Unified Sanitary Sewer District (Angola Neck Area)**
[Public Hearing Woods at Angola Beach](#)
3. **[Conditional Use No. 2523 filed on behalf of Tayra Trinidad](#)**

“AN ORDINANCE TO GRANT A CONDITIONAL USE OF LAND IN AN AR-1 AGRICULTURAL RESIDENTIAL DISTRICT FOR A NAIL SALON BUSINESS TO BE LOCATED ON A CERTAIN PARCEL OF LAND LYING AND BEING IN BALTIMORE HUNDRED, SUSSEX COUNTY, CONTAINING 0.55 ACRE, MORE OR LESS” (property lying on the east side of Powell Farm Road [S.C.R. 365], approximately 384 feet north of Burbage Road [S.C.R. 353]) (911 Address: 32379 Powell Farm Road, Frankford) (Tax Map Parcel: 134-11.00-219.03) (Zoning: AR-1 [Agricultural Residential District])

[Public Hearing CU2523](#)

4. **[Change of Zone No. 2018 filed on behalf of James Yerkie, II](#)**

“AN ORDINANCE TO AMEND THE COMPREHENSIVE ZONING MAP OF SUSSEX

COUNTY FROM AN MR MEDIUM RESIDENTIAL DISTRICT TO AN AR-1 AGRICULTURAL RESIDENTIAL DISTRICT FOR A CERTAIN PARCEL OF LAND LYING AND BEING IN CEDAR CREEK HUNDRED, SUSSEX COUNTY, CONTAINING 1.53 ACRES, MORE OR LESS” (property lying on the east side of Old Shawnee Road [S.C.R. 619] approximately 0.35-mile northeast of Shawnee Road [Rt. 36]) (911 Address: N/A) (Tax Map Parcel: 130-3.00-170.04) (Zoning: MR [Medium Density Residential District])

[Public Hearing CZ2018](#)

5. **Ordinance No. 23-01**

AN ORDINANCE TO AMEND THE SUSSEX COUNTY SEWER TIER MAP OF THE COMPREHENSIVE PLAN FROM THE TIER 4 AREA (SYSTEM OPTIONAL AREAS) TO THE TIER 2 (SUSSEX COUNTY PLANNING AREA) IN RELATION TO TAX PARCELS 433-11.00-17.00 and 433-11.00-17.01. The properties are lying on the east side of Dupont Boulevard (Route 113) on the north and south sides of Delaware Avenue (S.C.R. 54A), at the intersection of Dupont Boulevard (Route 113) and Delaware Avenue (S.C.R. 54A). 911 Addresses: 34910 & 33913 Delaware Avenue, Frankford. Tax Map Parcels: 433-11.00-17.00 & 17.01. Zoning: C-1 (General Commercial District).

[Public Hearing Sewer Tier Amendment](#)

Adjourn

-MEETING DETAILS-

In accordance with 29 Del.C. §10004(e)(2), this Agenda was posted on October 22, 2024 at 4:15 p.m. and at least seven (7) days in advance of the meeting.

This Agenda was prepared by the County Administrator and is subject to change to include the addition or deletion of items, including Executive Sessions, which arise at the time of the meeting.

Agenda items may be considered out of sequence.

The meeting will be streamed live at <https://sussexcountyde.gov/council-chamber-broadcast>.

The County provides a dial-in number for the public to comment during the appropriate time of the meeting. **Note, the on-line stream experiences a 30-second delay.**

Any person who dials in should listen to the teleconference audio to avoid the on-line stream delay.

To join the meeting via telephone, please dial:

Conference Number: 1-302-394-5036

Conference Code: 570176

Members of the public joining the meeting on the telephone will be provided an opportunity to make comments under the Public Comment section of the meeting and during the respective Public Hearing.

The Council meeting materials, including the “packet”, are electronically accessible on the County’s website at: <https://sussexcountyde.gov/agendas-minutes/county-council>.

SUSSEX COUNTY COUNCIL - GEORGETOWN, DELAWARE, OCTOBER 15, 2024

A regularly scheduled meeting of the Sussex County Council was held on Tuesday, October 15, 2024, at 10:00 a.m., in Council Chambers, with the following present:

Michael H. Vincent	President
John L. Rieley	Vice President
Cynthia C. Green	Councilwoman
Douglas B. Hudson	Councilman
Mark G. Schaeffer	Councilman
Todd F. Lawson	County Administrator
Gina A. Jennings	Finance Director
J. Everett Moore	County Attorney

The Invocation and Pledge of Allegiance were led by Mr. Vincent.

**Call to
Order**

Mr. Vincent called the meeting to order.

**M 526 24
Approve
Agenda**

A Motion was made by Mr. Hudson, seconded by Mr. Rieley, to approve the agenda as presented.

Motion Adopted: 4 Yeas, 1 Absent

**Vote by Roll Call: Mrs. Green, Yea; Mr. Schaeffer, Absent;
Mr. Hudson, Yea; Mr. Rieley, Yea;
Mr. Vincent, Yea**

Minutes

The minutes of the October 1, 2024, meeting were approved by consent.

Correspondence

Mr. Moore reported that correspondence was received from Unique Minds Changing Lives, Inc. thanking Council for their donation.

**Public
Comments**

There were no public comments.

**Adminis-
trator's
Report**

Mr. Lawson read the following information for his Administrator's Report:

1. Projects Receiving Substantial Completion

Per the attached Engineering Department Fact Sheets, the following projects have received Substantial Completion: Ashton Oaks effective September 26th; Plover Point (FKA Oak Landing) – Phase 3 (Construction Record) effective September 27th, Peninsula Lakes – Phase 15 (Construction Record) effective October 1st, Peninsula Lakes Phase 20 & Park & Ride Facility (Construction Record) effective October 1st, and The Knoll effective October 3rd.

**Adminis-
trator's
Report
(continued)**

2. Council Meeting Schedule

A reminder that Council will not meet on Tuesday, October 22nd. The next regularly scheduled Council meeting will be held on Tuesday, October 29th at 10:00 a.m.

[Attachments to the Administrator's Report are not attachments to the minutes.]

**Reassess-
ment Update
& Discussion**

Gina Jennings, Finance Director and Chris Keeler, Director of Assessment provided Council with an update regarding the tax reassessment. Mrs. Jennings reminded Council that this reassessment project started back in 2021 when the court mandated that we must move forward with reassessment. Mrs. Jennings reported that data mailers have been sent out to improved residential properties. There has been 198,771 images uploaded into the CAMA system. There has been 4,500 income and expense forms sent to improved commercial properties with a 21% response rate. Currently, Tyler is working on their review and value analysis that will be on the tentative value notices that will be mailed next month. There is a series of three short videos that will be shared to aid property owners in understanding what is reassessment; why is it being done, how the reassessment process works and how it may or may not impact your taxes and steps of the appeals process.

Mr. Keeler provided Council with a future timeline of the reassessment project as follows:

- Tentative notices will be mailed in November 2024**
- Informal appeals process with Tyler Technologies will be from November 2024 – January 2025**
- Assessment Rolls will be finalized in February 2025**
- Formal Appeals Process will be March – May 2025**
- Tax bills with the new assessed values and the new tax rate will be distributed in August 2025**

Mr. Keeler showed examples of the tentative value notices; three separate notices will be mailed: Residential/Commercial, Farmland in an agricultural program and farmland not in an Agricultural program. Mr. Keeler reported that the new tentative assessment is based on 100% of the current assessed value of your property as of July 1, 2023. The assessed values have been developed using recent valid market sales and economic data. The tax rates will change therefore, do not multiply your new tentative value by the current tax rate. Informal hearings are available to any property owner who desires to have their property value reviewed by Tyler Technologies.

**Reassess-
ment Update
& Discussion
(continued)**

Mr. Keeler reviewed the appeal process. Procedures and guidelines for the informal review process will be included on the back of each notice. The informal review process will be handled by Tyler Technologies which will be held at the West Complex starting on November 11, 2024, through January 31, 2025. He noted that scheduling does not begin until November 7th and notice must be received before scheduling an appointment. Any errors and omissions identified during the informal process will be resolved by Tyler Technologies before the formal assessment rolls are established on February 15th.

If an agreement cannot be reached during the informal appeal process, property owners have the opportunity for a formal appeal. To enter the formal appeal process, property owners must file an application with the Board of Assessment Review. Once filed, the process will have two steps. First, referees will meet one-on-one with property owner and second, a public hearing with the Board of Assessment review will be held. During the referee meeting, they will meet one-on-one with the appellant and review supporting evidence provided by appellant. A recommendation will then be made to the Board of Assessment Review. If an agreement is reached, a stipulation form is completed and forwarded to the Board of Assessment Review for review and decision. If an agreement cannot be reached, property owners will have the opportunity to participate in formal hearings regarding the assessed value of their property. The Board of Assessment Review will preside over the formal appeal hearings. These hearings will include a County attorney, County staff and board members that will be held in Council Chambers and open to the public. The Board will review recommendations from the Referee meetings as well as hear Formal Appeal from property owners. If an agreement cannot be reached property owners can appeal the Board of Assessment Review decision to Superior Court per State Code Title 9 §8312(c).

Mrs. Jennings reviewed the next steps for the project. Currently, the County is seeking Referees to review formal appeals with property owners appealing their value from Tyler Technologies. In addition, Council will need to appoint the members of the Board of Assessment Review.

**M 527 24
Approve
Board of
Assessment
Review
criteria**

A Motion was made by Mr. Hudson, seconded by Mr. Rieley, that be it moved that the Sussex County Council establish the following criteria for the Board of Assessment Review: members shall serve a term of 2 or 3 years, be residents of Sussex County, preferably have knowledge of assessment, real estate and/or the appraisal process, be generally available to sit on the board from March 1st through May 31st and not be an incumbent candidate or candidate elect for County, State or Federal office.

Motion Adopted: 5 Yeas

**Vote by Roll Call: Mrs. Green, Yea; Mr. Schaeffer, Yea;
Mr. Hudson, Yea; Mr. Rieley, Yea;**

Mr. Vincent, Yea

Stormwater BMP CO 1 Mark Parker, Assistant County Engineer presented change order no. 1 for stormwater BMP O&M on-call contract for Council's consideration.

M 528 24 Approve CO No. 1/ Stormwater BMP A Motion was made by Mr. Rieley, seconded by Mr. Hudson, be it moved based upon the recommendation of the Sussex County Engineering Department that the unit price of \$400.00 per hour for a three-person crew and change order no. 1 for contract G24-03, Stormwater BMP on-call contract be approved in the not to exceed amount of \$64,000.00.

Motion Adopted: 5 Yeas

Vote by Roll Call: Mrs. Green, Yea; Mr. Schaeffer, Yea; Mr. Hudson, Yea; Mr. Rieley, Yea; Mr. Vincent, Yea

MOT Services Award Mark Parker, Assistant County Engineer presented a recommendation of award for maintenance of traffic services for Council's consideration.

M 529 24 Approve MOT Services Recommendation A Motion was made by Mr. Hudson, seconded by Mr. Schaeffer, be it moved based upon the recommendation of the Sussex County Engineering Department that maintenance of traffic services contract G25-05 be awarded to Atlas Flasher & Supply Co. in the amount of \$419,725.00 for a three-year term with an optional one-year contract renewal and further that a fee may be negotiated and approved for custom MOT services to be provided in accordance with contract revisions by Atlas Flasher & Supply if deemed necessary by the Engineering Department.

Motion Adopted: 5 Yeas

Vote by Roll Call: Mrs. Green, Yea; Mr. Schaeffer, Yea; Mr. Hudson, Yea; Mr. Rieley, Yea; Mr. Vincent, Yea

Inland Bays CO No. 1 & 2 Patrick Brown, Project Engineer presented change order nos. 1 & 2 for the Inland Bays loop project for Council's consideration. Mr. Brown reviewed the items included in the change orders.

M 530 24 Approve CO Nos. 1 & 2/ Inland Bays A Motion was made by Mr. Schaeffer, seconded by Mr. Rieley, be it moved based upon the recommendation of the Sussex County Engineering Department that change order nos. 1 & 2 for contract S24-01, Inland Bays Regional Wastewater facility be approved increasing the contract amount by \$2,179,674.00 and \$136,460.00 respectively.

Motion Adopted: 5 Yeas

Vote by Roll Call: Mrs. Green, Yea; Mr. Schaeffer, Yea;

**Mr. Hudson, Yea; Mr. Rieley, Yea;
Mr. Vincent, Yea**

**Proposed Ordinance/
Amend Chapter 99-9C** Mr. Lawson presented a Proposed Ordinance entitled “AN ORDINANCE TO AMEND CHAPTER 99, ARTICLE II, SECTIONS 99-9, “PUBLIC HEARING ON PRELIMINARY PLAT APPROVAL OR DISAPPROVAL” OF THE CODE OF SUSSEX COUNTY REGARDING DESIGN CRITERIA FOR ALL SUBDIVISIONS” for Council’s consideration.

Jamie Whitehouse, Planning & Zoning Director provided an overview of the Proposed Ordinance.

Introduction of Proposed Ordinance Mr. Hudson introduced an Ordinance entitled “AN ORDINANCE TO AMEND CHAPTER 99, ARTICLE II, SECTIONS 99-9, “PUBLIC HEARING ON PRELIMINARY PLAT APPROVAL OR DISAPPROVAL” OF THE CODE OF SUSSEX COUNTY REGARDING DESIGN CRITERIA FOR ALL SUBDIVISIONS”.

**Proposed Ordinance/
Amend Chapter 99 & 115** Mr. Lawson presented a Proposed Ordinance entitled “AN ORDINANCE TO AMEND CHAPTER 99, ARTICLES I, III & IV, SECTIONS 99-5 “DEFINITIONS”, 99-21, “PUBLIC SITES AND OPEN SPACES”, §99-23 “PRELIMINARY PLAT REQUIREMENTS” AND CHAPTER 115, ARTICLES I & XXVIII, SECTION 115-4 “DEFINITIONS AND WORD USAGE” AND §115-220 “PRELIMINARY SITE PLAN REQUIREMENTS” OF THE CODE OF SUSSEX COUNTY REGARDING OPEN SPACE”.

Jamie Whitehouse, Planning & Zoning Director provided an overview of the Proposed Ordinance.

Introduction of Proposed Ordinance Mr. Rieley introduced an Ordinance entitled “AN ORDINANCE TO AMEND CHAPTER 99, ARTICLES I, III & IV, SECTIONS 99-5 “DEFINITIONS”, 99-21, “PUBLIC SITES AND OPEN SPACES”, §99-23 “PRELIMINARY PLAT REQUIREMENTS” AND CHAPTER 115, ARTICLES I & XXVIII, SECTION 115-4 “DEFINITIONS AND WORD USAGE” AND §115-220 “PRELIMINARY SITE PLAN REQUIREMENTS” OF THE CODE OF SUSSEX COUNTY REGARDING OPEN SPACE”.

Grant Requests Mrs. Jennings presented grant requests for Council’s consideration.

M 531 24 Friends of the Laurel Library A Motion was made by Mr. Rieley, seconded by Mr. Hudson to give \$1,900 (\$1,900 from Mr. Vincent’s Councilmanic Grant Account) to the Friends of the Laurel Library for their youth services program.

Motion Adopted: 5 Yeas

Vote by Roll Call: Mrs. Green, Yea; Mr. Schaeffer, Yea;

**Mr. Hudson, Yea; Mr. Rieley, Yea;
Mr. Vincent, Yea**

M 532 24 **A Motion was made by Mr. Hudson, seconded by Mr. Rieley to give \$1,500**
Selbyville **(\$1,500 from Mr. Hudson's Councilmanic Grant Account) to Selbyville**
Historical **Historical Society for the Townsend Building.**
Society

Motion Adopted: 5 Yeas

Vote by Roll Call: Mrs. Green, Yea; Mr. Schaeffer, Yea;
Mr. Hudson, Yea; Mr. Rieley, Yea;
Mr. Vincent, Yea

M 533 24 **A Motion was made by Mr. Schaeffer, seconded by Mrs. Green to give \$2,000**
Coastal **(\$1,000 from Mr. Schaeffer's Councilmanic Grant Account and \$1,000 from**
Concerts, **Mrs. Green's Councilmanic Grant Account) to Coastal Concerts, Inc. for**
Inc. **their 2024-2025 student scholarship program.**

Motion Adopted: 5 Yeas

Vote by Roll Call: Mrs. Green, Yea; Mr. Schaeffer, Yea;
Mr. Hudson, Yea; Mr. Rieley, Yea;
Mr. Vincent, Yea

M 534 24 **A Motion was made by Mr. Schaeffer, seconded by Mr. Hudson to give**
Cape **\$2,000 (\$1,000 from Mr. Schaeffer's Councilmanic Grant Account and**
Henlopen **\$1,000 from Mr. Hudson's Councilmanic Grant Account) to Cape Henlopen**
Educational **Educational Foundation for their teacher grant program.**
Foundation

Motion Adopted: 5 Yeas

Vote by Roll Call: Mrs. Green, Yea; Mr. Schaeffer, Yea;
Mr. Hudson, Yea; Mr. Rieley, Yea;
Mr. Vincent, Yea

M 535 24 **A Motion was made by Mr. Hudson, seconded by Mr. Schaeffer to give \$1,500**
Better **(\$1,500 from Mr. Vincent's Councilmanic Grant Account) to Better Homes**
Homes of **of Seaford, Inc. for their senior resource, activity and vendor events.**
Seaford, Inc.

Motion Adopted: 5 Yeas

Vote by Roll Call: Mrs. Green, Yea; Mr. Schaeffer, Yea;
Mr. Hudson, Yea; Mr. Rieley, Yea;
Mr. Vincent, Yea

M 536 24 **A Motion was made by Mr. Schaeffer, seconded by Mr. Hudson to give**
Good Ole **\$10,000 (\$2,000 from each Councilmanic Grant Account) to the Good Ole**
Boy **Boy Foundation, Inc. for Hurricane Helene relief.**

Foundation, Inc. **Motion Adopted: 5 Yeas**

**Vote by Roll Call: Mrs. Green, Yea; Mr. Schaeffer, Yea;
Mr. Hudson, Yea; Mr. Rieley, Yea;
Mr. Vincent, Yea**

Proposed Ordinance Introduction

Mr. Schaeffer introduced a Proposed Ordinance entitled “AN ORDINANCE TO AMEND THE COMPREHENSIVE ZONING MAP OF SUSSEX COUNTY FROM AN AR-1 AGRICULTURAL RESIDENTIAL DISTRICT TO A C-4 PLANNED COMMERCIAL DISTRICT FOR A CERTAIN PARCEL OF LAND LYING AND BEING IN LEWES AND REHOBOTH HUNDRED, SUSSEX COUNTY, CONTAINING 73.5 ACRES, MORE OR LESS” filed by Mulberry Knoll Associates, LLC.

Mr. Hudson introduced a Proposed Ordinance entitled “AN ORDINANCE TO AMEND THE COMPREHENSIVE ZONING MAP OF SUSSEX COUNTY FROM A B-1 NEIGHBORHOOD BUSINESS DISTRICT TO AN AR-1 AGRICULTURAL RESIDENTIAL DISTRICT FOR CERTAIN PARCELS OF LAND LYING AND BEING IN BALTIMORE HUNDRED, SUSSEX COUNTY, CONTAINING 5.171 ACRES, MORE OR LESS” filed on behalf of Melson Funeral Services, LTD.

Mr. Hudson introduced a Proposed Ordinance entitled “AN ORDINANCE TO AMEND THE COMPREHENSIVE ZONING MAP OF SUSSEX COUNTY FROM A GR GENERAL RESIDENTIAL DISTRICT TO A GR-RPC GENERAL RESIDENTIAL DISTRICT – RESIDENTIAL PLANNED COMMUNITY (181 DWELLING UNITS) DISTRICT FOR A CERTAIN PARCEL OF LAND LYING AND BEING IN INDIAN RIVER HUNDRED, SUSSEX COUNTY, CONTAINING 63.28 ACRES, MORE OR LESS” filed on behalf of ELU DeLuca Mid-Atlantic, LLC.

The Proposed Ordinances will be advertised for a public hearing.

CM Comments

There were no Council Member comments.

**M 537 24
Go Into
Executive
Session**

At 11:20 a.m., a Motion was made by Mr. Hudson, seconded by Mr. Rieley to recess the Regular Session and go into Executive Session to discuss matters relating to land acquisition.

Motion Adopted: 5 Yeas

**Vote by Roll Call: Mrs. Green, Yea; Mr. Schaeffer, Yea;
Mr. Hudson, Yea; Mr. Rieley, Yea;
Mr. Vincent, Yea**

Executive Session

At 11:25 a.m., an Executive Session of the Sussex County Council was held in the Basement Caucus Room to discuss matters related to land acquisition. The Executive Session concluded at 11:39 a.m.

M 538 24 Reconvene At 11:42 a.m., a Motion was made by Mr. Hudson, seconded by Mr. Schaeffer to come out of Executive Session back into Regular Session.

Motion Adopted: 5 Yeas

Vote by Roll Call: Mrs. Green, Yea; Mr. Schaeffer, Yea;
Mr. Hudson, Yea; Mr. Rieley, Yea;
Mr. Vincent, Yea

E/S Action There was no action related to Executive Session items.

M 539 24 Recess A Motion was made by Mr. Rieley, seconded by Mr. Schaeffer to recess until 1:30 p.m. Public Hearings.

Motion Adopted: 5 Yeas

Vote by Roll Call: Mrs. Green, Yea; Mr. Schaeffer, Yea;
Mr. Hudson, Yea; Mr. Rieley, Yea;
Mr. Vincent, Yea

M 540 24 Reconvene At 1:30 p.m., a Motion was made by Mr. Schaeffer, seconded by Mr. Hudson to reconvene.

Motion Adopted: 5 Yeas

Vote by Roll Call: Mrs. Green, Yea; Mr. Schaeffer, Yea;
Mr. Hudson, Yea; Mr. Rieley, Yea;
Mr. Vincent, Yea

Rules Mr. Moore read the rules of procedure for public hearings.

**Public Hearing/
CU2547** A Public Hearing was held on a Proposed Ordinance entitled "AN ORDINANCE TO GRANT A CONDITIONAL USE OF LAND IN AN AR-1 AGRICULTURAL RESIDENTIAL DISTRICT FOR AN AMENDMENT OF CONDITION "C" CONTAINED WITHIN CONDITIONAL USE NO. 2414 (ORDINANCE NO. 3031) REGARDING THE ALLOWANCE OF MAINTENANCE/REPAIR ON COMPANY EQUIPMENT/VEHICLES AND THE INCLUSION OF FUEL TANKS TO BE LOCATED ON A CERTAIN PARCEL OF LAND LYING AND BEING IN DAGSBORO HUNDRED, SUSSEX COUNTY, CONTAINING 4.72 ACRES, MORE OR LESS" (property lying on the east side of Millsboro Highway [Rt. 30] approximately 0.89 mile south of Laurel Road [Rt. 24]) (911 Address: 32605 Millsboro Highway, Lewes) (Tax Map Parcel: 233-13.00-1.04) filed on behalf of Justice Boyz Properties, LLC.

The Planning & Zoning Commission held a Public Hearing on the application on September 11, 2024. At the meeting of September 11, 2024, the Planning &

**Public
Hearing/
CU2547
(continued)**

Zoning Commission recommended approval of the application for the reasons as outlined.

The Council found that Mr. Travis Justice spoke on behalf of the application; that they would like to Amend Condition “C” in C/U 2414 regarding the allowance of maintenance and repair on the company equipment and vehicles and for the inclusion of fuel tanks to be located on the property; that a final site plan was submitted to show where the fuel tanks will be located; that the work will be done inside.

There were no public comments.

The Public Hearing and public record were closed.

**M 541 24
Adopt
Ordinance
No. 3050/
CU2547**

A Motion was made by Mr. Rieley, seconded by Mr. Hudson to Adopt Ordinance No. 3050 entitled “AN ORDINANCE TO GRANT A CONDITIONAL USE OF LAND IN AN AR-1 AGRICULTURAL RESIDENTIAL DISTRICT FOR AN AMENDMENT OF CONDITION “C” CONTAINED WITHIN CONDITIONAL USE NO. 2414 (ORDINANCE NO. 3031) REGARDING THE ALLOWANCE OF MAINTENANCE/REPAIR ON COMPANY EQUIPMENT/VEHICLES AND THE INCLUSION OF FUEL TANKS TO BE LOCATED ON A CERTAIN PARCEL OF LAND LYING AND BEING IN DAGSBORO HUNDRED, SUSSEX COUNTY, CONTAINING 4.72 ACRES, MORE OR LESS” for the reason given by the Planning & Zoning Commission as follows:

- 1. Delete Condition “C” of Conditional Use #2414 Justice Boyz Properties, LLC, and replace it with any vehicle or equipment repair shall occur indoors and all fuels, chemicals and oils shall be properly stored and disposed of.**

Motion Adopted: 5 Yeas

**Vote by Roll Call: Mrs. Green, Yea; Mr. Schaeffer, Yea;
Mr. Hudson, Yea; Mr. Rieley, Yea;
Mr. Vincent, Yea**

**Public
Hearing/
CZ2030**

A Public Hearing was held on a Proposed Ordinance entitled “AN ORDINANCE TO AMEND THE COMPREHENSIVE ZONING MAP OF SUSSEX COUNTY FROM AN AR-1 AGRICULTURAL RESIDENTIAL DISTRICT TO A C-3 HEAVY COMMERCIAL DISTRICT FOR A CERTAIN PARCEL OF LAND LYING AND BEING IN GEORGETOWN HUNDRED, SUSSEX COUNTY, CONTAINING 3.080 ACRES, MORE OR LESS” (property and lying on the northeast side of Zoar Road [S.C.R. 48], approximately 0.238 of a mile south of Sussex Pines Road [S.C.R. 324]) (911 Address: 22035 Zoar Road, Georgetown) (Tax Map Parcel: 135-23.00-24.00) filed on behalf of ACR Auto Center, LLC.

**Public
Hearing/
CZ2030
(continued)**

The Planning & Zoning Commission held a Public Hearing on the application on September 11, 2024. At the meeting of September 11, 2024, the Planning & Zoning Commission recommended approval of the application for the 7 reasons as outlined.

The Council found that Mr. Ken Christenberry, of AXIOM Engineering, spoke on behalf of the application; that the application is for an auto collision repair shop about half mile north at 43 North St.; that the applicant has run out of room at his current space and there is about a half-acre at the new location so he will be able to do more body work; that it is an old commercial building that was used for a contractors business prior; that there is currently a 6-foot privacy fence around the property that is in good condition that they plan to keep; that the zoning is in character with zoning in the area; that the staff analysis document indicates that portions of the developing areas with good road access and few nearby homes should allow for businesses and industrial; that there is one neighborhood comment that does not express opposition.

There were no public comments.

The Public Hearing and public record were closed.

**M 542 24
Adopt
Ordinance
No. 3051/
CZ2030**

A Motion was made by Mr. Rieley, seconded by Mr. Hudson to Adopt Ordinance No. 3051 entitled “AN ORDINANCE TO AMEND THE COMPREHENSIVE ZONING MAP OF SUSSEX COUNTY FROM AN AR-1 AGRICULTURAL RESIDENTIAL DISTRICT TO A C-3 HEAVY COMMERCIAL DISTRICT FOR A CERTAIN PARCEL OF LAND LYING AND BEING IN GEORGETOWN HUNDRED, SUSSEX COUNTY, CONTAINING 3.080 ACRES, MORE OR LESS” for the reasons given by the Planning & Zoning Commission as follows:

- 1. The property has a prior history of commercial uses. According to the testimony in the record, this property was previously the site of an electrical business under Conditional Use # 1598. The proposed C-3 zoning is consistent with the prior use of the property.**
- 2. C-3 Heavy Commercial Zoning is designed to allow auto-oriented retail and service businesses that serve local and regional residents. Permitted Uses include retail uses, restaurants, offices and vehicle service stations. Although a number of uses are permitted, this Applicant intends to use the site for auto repair and auto body work.**
- 3. This property has frontage along Zoar Road and it directly across for approximately 45 acres of land that has a C-1 Zoning. This is an appropriate location for C-3 Zoning.**
- 4. This property is located in the Developing Area according to the current Sussex County Land Use Plan. This proposed commercial zoning is appropriate in this Area according to the Plan.**

**M 542 24
Adopt
Ordinance
No. 3051/
CZ2030**

- 5. The proposed rezoning meets the general purpose of the Zoning Code by promoting the orderly growth, convenience, order prosperity and welfare of the County.**
- 6. No parties appeared in opposition to this rezoning application and one letter of support was received with regard to the Application.**
- 7. Any future use of the property will be subject to Site Plan review by the Sussex County Planning and Zoning Commission.**

Motion Adopted: 5 Years

**Vote by Roll Call: Mrs. Green, Yea; Mr. Schaeffer, Yea;
Mr. Hudson, Yea; Mr. Rieley, Yea;
Mr. Vincent, Yea**

**Public
Hearing/
Ord. 23-08
& CZ1976**

A Public Hearing was held on a Proposed Ordinance entitled “AN ORDINANCE TO AMEND THE FUTURE LAND USE MAP OF THE COMPREHENSIVE PLAN IN RELATION TO TAX PARCEL 135-11.00-82.00” (property lying on the northeast side of Gravel Hill Road [Rt. 30], approximately 0.14 mile southeast of Lewes Georgetown Highway [Rt. 9]) (911 Address: 20093 Gravel Hill Road, Georgetown) (Tax Map Parcel: 135-11.00-82.00)

The Planning & Zoning Commission held a Public Hearing on the application on September 11, 2024. At the meeting of September 25, 2024, the Planning & Zoning Commission recommended the adoption of the Ordinance for the 6 reasons as outlined.

A Public Hearing was held on a Proposed Ordinance entitled “AN ORDINANCE TO AMEND THE COMPREHENSIVE ZONING MAP OF SUSSEX COUNTY FROM AN AR-1 AGRICULTURAL RESIDENTIAL DISTRICT TO A LI-1 LIMITED INDUSTRIAL DISTRICT FOR A CERTAIN PARCEL OF LAND LYING AND BEING IN GEORGETOWN HUNDRED, SUSSEX COUNTY, CONTAINING 14.426 ACRES, MORE OR LESS” (properties lying on the northeast side of Gravel Hill Road [Rt. 30], approximately 0.14 mile southeast of Lewes Georgetown Highway [Rt. 9]) (911 Address: 20093 Gravel Hill Road, Georgetown) (Tax Map Parcel: 135-11.00-82.00) filed on behalf of John H. Legg

The Planning & Zoning Commission held a Public Hearing on the application on September 11, 2024. At the meeting of September 25, 2024, the Planning & Zoning Commission recommended approval of the application for the 7 reasons as outlined.

The Council found that Mr. Hal Dukes, of Tunnell & Raysor, PA, spoke on behalf of the applicant that the site in question has been used in its present state for almost 100 years; that in the late 1920’s and 1930’s it was a concrete yard and the Federal government took control during World War II because it was located along the rail line; that when the site came back the

**Public
Hearing/
Ord. 23-08
& CZ1976
(continued)**

rail line was recorded with the County, but the concrete site was not and we are trying to correct the situation now; that a presentation was given a year or two ago concerning this case and it is requested that all of those documents be added to this case as reference.

There were no public comments.

The Public Hearing and public record were closed.

**M 543 24
Adopt
Ordinance
No. 3052/
Ord. 23-08**

A Motion was made by Mr. Rieley, seconded by Mr. Hudson to Adopt Ordinance No. 3052 entitled “AN ORDINANCE TO AMEND THE FUTURE LAND USE MAP OF THE COMPREHENSIVE PLAN IN RELATION TO TAX PARCEL 135-11.00-82.00” for the reasons given by the Planning & Zoning Commission as follows:

- 1. The parcel is currently designated as being within the “Low Density Area” according to the Sussex County Future Land Use Map contained within the Comprehensive Plan. This application seeks to convert the property to the “Industrial Area” designation.**
- 2. The site has been used for heavy commercial and industrial purposes for decades. There was testimony in the record that this type of use relates back as far as World War Two and the buildup of Fort Miles. It was an oversight to omit this property from the Industrial Area designation within the current Future Land Use Map given the longstanding use of the property. This amendment corrects that oversight.**
- 3. According to the County’s Comprehensive Plan, the “Industrial Area” is intended for “lands devoted to concentrations of larger industrial uses including heavier industry, light industry, warehousing, and flex space. Appropriate development in these areas could take the form of conventional industrial parks or planned business parks with a unified design that incorporates a combination of light industry and other business uses.” The change in the Future Land Use Map to recognize the ongoing use of the property is appropriate.**
- 4. The property is also located along Route 30, in close proximity to the intersection with Route 9. The Industrial Area designation is appropriate at this location.**
- 5. Because this Map Amendment simply reflects the longstanding use of this particular property, this revision to the Future Land Use Map will not adversely affect neighboring properties, area roadways, or future land-use planning in the area.**
- 6. This revision of the Future Land Use Map is appropriate given the particular circumstances involved at this location. When several factors like these exist, the consideration and approval of an amendment to the Future Land Use Map is appropriate.**

Motion Adopted: 5 Yeas

**Vote by Roll Call: Mrs. Green, Yea; Mr. Schaeffer, Yea;
Mr. Hudson, Yea; Mr. Rieley, Yea;
Mr. Vincent, Yea**

**M 544 24
Adopt
Ordinance
No. 3053/
CZ1976**

A Motion was made by Mr. Rieley, seconded by Mr. Hudson to Adopt Ordinance No. 3053 entitled “AN ORDINANCE TO AMEND THE COMPREHENSIVE ZONING MAP OF SUSSEX COUNTY FROM AN AR-1 AGRICULTURAL RESIDENTIAL DISTRICT TO A LI-1 LIMITED INDUSTRIAL DISTRICT FOR A CERTAIN PARCEL OF LAND LYING AND BEING IN GEORGETOWN HUNDRED, SUSSEX COUNTY, CONTAINING 14.426 ACRES, MORE OR LESS” for the reasons given by the Planning & Zoning Commission as follows:

- 1. The Commission has just made a recommendation to Sussex County Council that the County’s Future Land Use Map designation for this property should be corrected to the “Industrial Area” designation to reflect its undisputed historical use for commercial and industrial purposes. The LI-1 Zoning District is an appropriate zoning designation within the “Industrial Area” according to the County’s Future Land Use Map and the Comprehensive Plan.**
- 2. The property is also located along Route 30 in close proximity to the intersection with Route 9. This location, near two significant Sussex County roadways, is appropriate for LI-1 Zoning.**
- 3. The site is across Route 30 from the State of Delaware Department of Transportation’s Gravel Hill storage and staging facility. This facility utilizes rail and truck access and provides parking for DelDOT equipment and materials used in road maintenance and construction. LI-1 zoning at the Applicant’s property is similar to, and compatible with, the intensive uses at the DelDOT yard across the road.**
- 4. The site has been used for heavy commercial and industrial purposes for decades. There was testimony in the record that this type of use relates back as far as World War Two and the buildup of Fort Miles. Other commercial and industrial uses have continued without interruption on this site since then. This rezoning will bring the property’s zoning into conformity with its longstanding use.**
- 5. The proposed LI-1 Zoning at this location is consistent with the purposes of that zoning district as stated in Section 115-92 of the Sussex County Zoning Code.**
- 6. The rezoning will promote the local economy and will create and preserve jobs in the area for Sussex County residents.**
- 7. Any future use and development of the property will be subject to site plan review by the Sussex County Planning and Zoning Commission.**

Motion Adopted: 5 Yeas

**Vote by Roll Call: Mrs. Green, Yea; Mr. Schaeffer, Yea;
Mr. Hudson, Yea; Mr. Rieley, Yea;
Mr. Vincent, Yea**

**M 545 24
Adjourn**

**A Motion was made by Mr. Hudson, seconded by Mr. Rieley, to adjourn at
1:53 p.m.**

Motion Adopted: 5 Yeas

**Vote by Roll Call: Mrs. Green, Yea; Mr. Schaeffer, Yea;
Mr. Hudson, Yea; Mr. Rieley, Yea;
Mr. Vincent, Yea**

Respectfully submitted,

**Tracy N. Torbert
Clerk of the Council**

{An audio recording of this meeting is available on the County's website.}

GINA A. JENNINGS, MBA, MPA
FINANCE DIRECTOR

(302) 855-7741 T
(302) 855-7749 F
gjennings@sussexcountyde.gov



Sussex County

DELAWARE
sussexcountyde.gov

MEMORANDUM:

TO: Sussex County Council
The Honorable Michael H. Vincent, President
The Honorable John L. Rieley, Vice President
The Honorable Cynthia C. Green
The Honorable Douglas B. Hudson
The Honorable Mark G. Schaeffer

FROM: Gina A. Jennings
Finance Director/Chief Operating Officer

RE: **Lodging Tax - Short-Term Rentals**

DATE: October 24, 2024

At the end of September, the Governor signed House Substitute 2 for HB 168. The bill created a short-term lodging tax and license services for the State of Delaware. It also authorized Sussex County to impose a lodging tax of no more than 3 percent on short-term rentals.

As you know Sussex County began collecting a lodging tax on hotels, motels, and tourist homes in unincorporated area in 2020. With a short break from the tax during COVID, the County has collected \$3.4 million since its inception. The County has spent more than half of those funds to help with dredging White Creek Canal and two Fenwick Island channels.

I have an ordinance for you to introduce on Tuesday that would add short-term rentals to the County's lodging tax collections. Just as with the current lodging tax, these collections are restricted and can only be used for beach nourishment, waterway dredging, economic development, tourism programs, recreational activities, water quality and flood control projects, and workforce and affordable housing programs.

Attached is a draft of the ordinance for introduction.

If you have any questions, please feel free to contact me.

Attachment

ORDINANCE NO. _____

AN ORDINANCE TO AMEND CHAPTER 103, ARTICLE VI (“LODGING TAX”) OF THE CODE OF SUSSEX COUNTY TO INCLUDE THE IMPOSITION OF A LODGING TAX OF THREE PERCENT (3%) OF THE RENT FOR SHORT-TERM RENTALS IN THE UNINCORPORATED AREAS OF SUSSEX COUNTY IN ACCORDANCE WITH 9 DEL. C. § 8112(c) AND 30 DEL. C. § 6201.

1 WHEREAS, House Substitute No. 2 for House Bill No. 168 as amended
2 by House Amendment No. 1 and entitled, “An Act to Amend Titles 9 and 30 of
3 the Delaware Code Relating to Lodging Tax” (“HB 168”) was enacted by the
4 Delaware General Assembly on June 27, 2024, and signed into law by Governor
5 John Carney on October 2, 2024; and
6

7 WHEREAS, HB 168, in part, amended Title 30, Part V to create a new
8 Chapter 62, entitled “Short-Term Rental Lodging Tax”, which imposed a lodging
9 tax on short-term rentals located in the State of Delaware; and
10

11 WHEREAS, HB 168 also amended 9 *Del. C.* § 8112(c) to authorize
12 Sussex County to impose, by ordinance, a local lodging tax of no more than
13 three percent (3%) of the rent, in addition to the tax imposed by the State, for
14 short-term rentals as defined in 30 *Del. C.* § 6201, that are located within the
15 unincorporated areas of Sussex County; and
16

17 WHEREAS, in accordance with 9 *Del. C.* § 8112(c), it is the intent of the
18 Sussex County Council to impose and collect a three percent (3%) lodging tax on
19 short-term rentals in the unincorporated areas of Sussex County in a manner
20 similar to the State.
21

22 NOW, THEREFORE, THE COUNTY OF SUSSEX HEREBY ORDAINS:
23

24 Section 1. Chapter 103, Article VI (“Lodging Tax”), § 103-39 of the Code
25 of Sussex County is hereby amended by inserting the underlined and italicized
26 language and deleting the bracketed language as follows:
27

28 “Article VI Lodging Tax
29

30 § 103-39 Definitions.
31

32 The definitions in 30 *Del. C.* § 6101 (Lodging Tax Definitions) and 30 *Del.*
33 *C. § 6201 (Short-Term Rental Lodging Tax)* are hereby incorporated by
34 reference.
35

36 Section 2. Chapter 103, Article VI (“Lodging Tax”), §§ 103-40A. and B. of
37 the Code of Sussex County are hereby amended by inserting the underlined and
38 italicized language and deleting the bracketed language as follows:

39
40
41
42
43
44
45
46
47
48
49
50
51
52
53
54
55
56
57
58
59
60
61
62
63
64
65
66
67
68

§ 139-40 Levy of Tax; Exemption; Collection; Payment

- A. A tax is hereby levied at the rate of three percent (3%) of the rent upon every occupancy of a room or rooms in a hotel, motel, [or] tourist home or short-term rental within unincorporated sections of Sussex County. Such tax shall be in addition to the lodging tax imposed by the State pursuant to 30 *Del. C.* §§ 6102 and 6202.

- B. [No lodging tax pursuant to this Article shall be imposed for reservations or contracts paid in full prior to January 1, 2020.]The lodging tax on short-term rentals only applies to short-term rental agreements entered into on or after January 1, 2025.

Section 3. Effective Date. This Ordinance shall become effective January 1, 2025.

Synopsis

In accordance with 9 *Del. C.* § 8112(c), this Ordinance amends Sussex County Code, Chapter 103, Article VI (“Lodging Tax”) §§ 103-39 and 103-40A. and B. to impose a local lodging tax of three percent (3%) of the rent for short-term rentals (as defined in 30 *Del. C.* § 6201) that are located in the unincorporated areas of Sussex County. Such tax shall be in addition to the lodging tax imposed by the State pursuant to 30 *Del. C.* §§ 6102 and 6202. The lodging tax on short-term rentals only applies to short-term rental agreements entered into on or after January 1, 2025.

All new text is underlined and italicized. All deleted text is in brackets.

ENGINEERING DEPARTMENT

MIKE HARMER, P.E.
SUSSEX COUNTY ENGINEER

(302) 855-7370 T
(302) 854-5391 F
mike.harmer@sussexcountyde.gov



Sussex County

DELAWARE
sussexcountyde.gov

Memorandum

TO: Sussex County Council
The Honorable Michael H. Vincent, President
The Honorable John L. Rieley, Vice President
The Honorable Cynthia C. Green
The Honorable Douglas B. Hudson
The Honorable Mark G. Schaeffer

FROM: Mike Harmer, P.E., County Engineer

RE: **JP COURT ANNEX, PROJECT C25-06**
A. *TEVEBAUGH ARCHITECTS – EXPANSION FEASIBILITY STUDY*

DATE: October 29, 2024

On August 13, 2024, County Council authorized the Engineering Department to request a proposal from Tevebaugh Associates, Inc., utilizing an exiting contract with the state. Tevebaugh has proposed an expansion feasibility study that provides an analysis of the existing buildings to provide a foundation for options development and cost estimating. Based on the findings, the County will have an option to either renovate the JP Court Annex Building or demolish and construct a new adjacent building or addition for the Sussex County Administration Building.

The Engineering Department met with Tevebaugh on August 26, 2024, to discuss the needs and options for the Annex Building. After several rounds of discussion, a scope and expectations of the study were defined. As part of this study, Tevebaugh will solicit information about County operational functions, current and future staffing, and space requirements to be included in the project for each County department, while also looking at technology and security needs.

The Engineering Department now requests Council's approval of Tevebaugh Associates' proposal in the amount of \$200,000.00. Upon completion of this study, the Engineering Department will solicit a design proposal from Tevebaugh Associates, Inc., which will be presented to County Council for approval sometime in 2025.



ENGINEERING DEPARTMENT

ADMINISTRATION (302) 855-7718
AIRPORT & BUSINESS PARK (302) 855-7774
ENVIRONMENTAL SERVICES (302) 855-7730
RECORDS MANAGEMENT (302) 855-5033
UTILITY ENGINEERING (302) 855-7717
UTILITY PERMITS (302) 855-7719
UTILITY PLANNING (302) 855-1299
FAX (302) 855-7773



Sussex County

DELAWARE
sussexcountyde.gov

MIKE HARMER, P.E.
SUSSEX COUNTY ENGINEER
ROBERT L. BRYANT, A.A.E.
AIRPORT MANAGER

MEMORANDUM

TO: Sussex County Council
The Honorable Michael H. Vincent, President
The Honorable John L. Rieley, Vice President
The Honorable Douglas B. Hudson
The Honorable Cynthia Green
The Honorable Mark Schaeffer

FROM: Robert L. Bryant, A.A.E., Airport Manager

DATE: October 29, 2024

REFERENCE: CONSTRUCT PARALLEL TAXIWAY B – PHASE 2 – PROJECT A24-15
A) RECOMMENDATION TO AWARD
B) DELTA AIRPORT CONSULTANTS – TASK ORDER NO. 5

The Engineering Department, on behalf of the Delaware Coastal Airport, is seeking approval by the Sussex County Council to issue a “Notice of Award” and authority to sign a “Construction Contract” with Allan Myers MD, Inc., Fallston, Maryland, in the amount of \$3,375,555.00 for work associated with construction of a New Parallel Taxiway Bravo (B) – Phase 2 (Construction).

On May 1, 2024, the Engineering Department, on behalf of the Delaware Coastal Airport, held a Bid Opening for the New Parallel Taxiway Bravo (B) – Phase 2 (Construction). The following three bids were received:

Allan Myers MD, Inc.	\$3,375,555.00
George & Lynch, Inc.	\$3,825,462.00
Atlantic Contracting & Materials Co., Inc.	\$4,077,074.00

During its meeting held on June 25, 2024, Sussex County Council approved submittal to the Federal Aviation Administration an Airport Improvement Program grant application in the amount of \$3,473,464 which will pay 90% of the total project cost of **\$3,859,405**. Sussex County is responsible to pay the remaining \$385,941 (10%) of the total project cost, which is derived as follows:



Allan Myers MD, Inc. Low Bid	\$3,375,555.00
Delta Airport Consultants, Inc. (Construction Administrative Services)	\$ 480,000.00
Independent Fee Estimate Cost (FAA required)	<u>\$ 3,850.00</u>
TOTAL CONSTRUCT PARALLEL TAXIWAY B – PHASE 2	\$3,859,405.00

On September 12, 2024, the Federal Aviation Administration and Sussex County finalized signatures and execution of the Airport Improvement Program grant in the amount of \$3,473,464.

In accordance with the provisions of the AIP grant, the Airport Manager in coordination with the Engineering Department recommends approval to issue a “Notice of Award” and authority to sign a “Construction Contract” with Allan Myers MD, Inc. in the amount of \$3,375,555.00 for work associated with construction of a New Parallel Taxiway Bravo (B) – Phase 2 (Construction).

To support construction activities, our current on-call Aeronautical Consultant, Delta Airport Consultants, was requested to provide a proposal to cover the required Construction Administration Services on the project in accordance with County and FAA requirements. The scope of services in the submitted proposal is consistent with past major airport capital improvement projects. Delta’s proposal in the amount of \$480,000.00 has been reviewed by the Airport Manager and the Engineering Department and is acceptable. As noted in the above summary, the cost for Construction Administration services is incorporated into the approved FAA project grant.

Attachments:

- Allan Myers MD, Inc., Bid Documents
- Contract Award Extension
- Bid Tabulation
- Delta Airport Consultants TO 5

Bidder Proposal Checklist

Project Name: Construct Taxiway B - Bid Package 1
Airport: Delaware Coastal Airport
Location: Georgetown, Delaware
Bid Submitted to: Sussex County Council

The Bidder must include the following items, or their bid proposal may be deemed non-responsive. The Bid Proposal Checklist shall be completed and submitted with the bid. The Sussex County Council reserves the right to accept or reject any and all bids that are deemed not to be in the best interest of the Sussex County Council at its sole discretion.

Required Documentation for AIP Funded Projects

- Signed Bid Proposal Certification
- Completed Bid Schedule Form
 - Confirm Mobilization price meets Section C-105 requirements
- Signed Certification Regarding Federal Contract Language
- Signed Certification of Buy American Compliance
- Signed Certification Regarding Debarment
- Signed Certification Regarding Lobbying
- Signed Certification Regarding Trade Restriction
- Signed Certification Regarding Tax Delinquency and Felony Convictions
- Signed DBE Utilization Form
 - DBE Good Faith Effort documentation included
- Signed DBE Letter of Intent (For each DBE Subcontractor)
- Signed Subcontractor List
- Section 20-02 Proposal Requirements
 - Part A: Evidence of Competency to Perform Work
 - Part B or C: Evidence of Financial Responsibility
- Signed Bid Bond

Name of Bidder:

Allan Myers MD, Inc.

Revised Bid Proposal Forms

for

Construct Taxiway B - Bid Package 1

at

Delaware Coastal Airport

Bidder Proposal Certification

Name of Bidder: Allan Myers MD, Inc.

For Project: Construct Taxiway B - Bid Package 1

At Airport: Delaware Coastal Airport
Georgetown, Delaware

Submitted to: Sussex County Council

AIP Project No.: 3-10-0007-040-2023 (Design)
AIP Project No.: 3-10-0007-039-Pending (Construction)

In compliance with the Invitation for Bids, the undersigned hereby proposes to furnish the materials and labor and to perform the work for the completion of items listed in the schedule included herein in strict conformance with the Invitation for Bids (advertisement), Plans, Construction Details, General and Special Provisions, Technical Specifications, and all other contract documents for the consideration of the prices quoted in the following schedule of bid items. The undersigned agrees, upon receipt of written notice of award, that it will execute a contract in accordance with the bid as accepted and give the required contract bonds with good and sufficient surety, within fifteen (15) calendar days after receipt of notice of formal award of contract and presentation of the prescribed forms.

It is agreed that the undersigned has informed itself fully in regard to all conditions pertaining to the place where the work is to be done, that it has examined the plans and specifications for the work and contractual documents thereto and has read all the special provisions furnished prior to the opening of bids, and that it has satisfied itself relative to the work to be performed.

It is agreed that the description under each item, being stated, implies although it does not mention, all incidentals and that the prices stated are intended to cover all such work, materials, and incidentals as constitute bidders obligations as described in the specifications, and any details not specifically mentioned, but evidently included in the contract shall be compensated for in the item which most logically includes it.

It is understood that this proposal is submitted for the purpose of obtaining the work included in the subject project at the Airport. Said work includes the following general items:

(1) Construct Taxiway B

Said work is described in the project contract documents which also include the place, date, and time of opening proposals.

It is understood that separate contracts on individual schedules of work may be awarded, when included in the bid documents.

It is understood that all workmanship and materials under all items of work are guaranteed for one year from the date of final acceptance.

It is understood that the Owner reserves the right to accept or reject any or all bids and waive informalities.

It is understood that the quantities of work to be done are approximate only and are intended principally to serve as a guide in evaluation of proposals, with the right reserved by the Owner to delete minor bid items.

The undersigned agrees that, if awarded the contract, it will commence the work not later than ten (10) days from receipt of the Notice to Proceed and that it will complete the work within the time stipulated in this proposal.

It is understood that for each calendar day that any work remains uncompleted after the contract time (including all extensions and adjustments as provided in Section 80, paragraph 80-07, *Determination and Extension of Contract Time*) liquidated damages will be assessed in accordance with Special Provision Section "Liquidated Damages" and will be deducted from any money due or to become due to the Contractor or its Surety. Such deducted sums shall not be deducted as a penalty but shall be considered as liquidation of a reasonable portion of damages that will be incurred by the Owner should the Contractor fail to complete the work in the time provided in its contract.

Enclosed is security as required, consisting of a certified check or a bid bond (Circle One) payable to the Sussex County Council, in the amount of \$ 10% of bid amount.

This amount equals 10 percent of the total amount bid submitted by the Contractor.

It is understood that this project is funded by federal, state, and local monies, and the Contractor shall be subject to all laws and regulations applicable to recipients of such funds.

The Contractor shall be a licensed Contractor registered with the State of Delaware, shall list its registration number at the end of the proposal in the designated location, and shall enclose a copy of its licensing certificate. In the event that the registration is pending, or in process, a statement as to the status shall be included instead.

The undersigned hereby acknowledges the receipt of the following Addenda to the Contract Documents.

Addendum No. One, issued	<u>4/17/2024</u>	(DATE)
Addendum No. Two, issued	<u>4/25/2024</u>	(DATE)
Addendum No. Three, issued	_____	(DATE)
Addendum No. Four, issued	_____	(DATE)
Addendum No. Five, issued	_____	(DATE)

Name of Bidder: Allan Myers MD, Inc.

Physical Business Address: 2011 Belair Road
(No P.O. Boxes) Fallston, MD 21047

Email Address: rich.dungan@allanmyers.com

Signature: 

Name: (type or print) Richard W. Dungan

Official Title: President

Date: 05/01/2024

Telephone No.: (410) 776-2000

Delaware Contractor's License Number: 1999200160

REVISED BID FORM

Date: 5/1/24

Bid Proposal Summary For All Work Depicted In The Plans And Specifications

ITEM NO.	APPROX. QUANTITY	ITEM WITH UNIT PRICE WRITTEN IN WORDS	UNIT PRICES IN FIGURES		EXTENDED TOTAL	
			DOLLARS	CENTS	DOLLARS	CENTS
1 C-100	1 LS	CONTRACTOR QUALITY CONTROL PROGRAM <u>FOUR HUNDRED FORTY THREE THOUSAND THREE HUNDRED TWENTY DOLLARS</u> PER LUMP SUM	443,200.00 443,320.00		443,320.00	
2 C-102	3,200 LF	INSTALLATION AND REMOVAL OF SILT FENCE <u>THREE DOLLARS</u> PER LINEAR FOOT	3.00		9600.00	
3 C-102	300 LF	INSTALLATION AND REMOVAL OF SUPER SILT FENCE <u>TWELVE DOLLARS</u> PER LINEAR FOOT	12.00		3600.00	
4 C-102	4 EA	STONE CONSTRUCTION ENTRANCE <u>SIX THOUSAND DOLLARS</u> PER EACH	6000.00		24,000.00	
5 C-102	3 EA	STONE CHECK DAM <u>EIGHTEEN HUNDRED DOLLARS</u> PER EACH	1800.00		5400.00	
6 C-102	14 EA	INLET PROTECTION <u>FOUR HUNDRED DOLLARS</u> PER EACH	400.00		5600.00	
7 C-102	2 EA	CULVERT INLET PROTECTION <u>FIVE HUNDRED DOLLARS</u> PER EACH	500.00		1000.00	
8 C-102	750 LF	COMPOST FILTER LOG <u>ELEVEN DOLLARS</u> PER LINEAR FOOT	11.00		8250.00	
9 C-102	2,150 LF	ORANGE CONSTRUCTION FENCE <u>THREE DOLLARS</u> PER LINEAR FOOT	3.00		6450.00	
10 C-102	2 EA	SKIMMER DEWATERING DEVICE <u>THREE THOUSAND DOLLARS</u> PER EACH	3000.00		6000.00	

REVISED BID FORM

Bid Proposal Summary For All Work Depicted In The Plans And Specifications

ITEM NO.	APPROX. QUANTITY	ITEM WITH UNIT PRICE WRITTEN IN WORDS	UNIT PRICES IN FIGURES	EXTENDED TOTAL
			DOLLARS CENTS	DOLLARS CENTS
11 C-102	280 TN	NO. 57 STONE <u>EIGHTY FIVE DOLLARS</u> PER TON	85.00	23,800.00
12 C-102	7 AC	TEMPORARY SEEDING <u>TWO THOUSAND DOLLARS</u> PER ACRE	2000.00	14,000.00
13 C-105	1 LS	MOBILIZATION <u>THREE HUNDRED THIRTY THOUSAND DOLLARS</u> PER LUMP SUM	330,000.00	330,000.00
14 P-101	150 SY	BITUMINOUS PAVEMENT REMOVAL <u>TWELVE DOLLARS</u> PER SQUARE YARD	12.00	1800.00
15 P-101	1,500 SY	CONCRETE PAVEMENT REMOVAL (6" DEPTH) <u>FORTY DOLLARS</u> PER SQUARE YARD	40.00	60,000.00
16 P-101	125 SY	CONCRETE PAVEMENT REMOVAL (FULL DEPTH) <u>ONE HUNDRED FORTY EIGHT DOLLARS</u> PER SQUARE YARD	148.00	18,500.00
17 P-101	600 LF	JOINT AND CRACK REPAIR (TYPE A) <u>EIGHTEEN DOLLARS</u> PER LINEAR FOOT	18.00	10,800.00
18 P-101	400 LF	JOINT AND CRACK REPAIR (TYPE B) <u>EIGHTEEN DOLLARS</u> PER LINEAR FOOT	18.00	7200.00
19 P-101	2,500 SY	COLD MILLING (2" DEPTH) <u>EIGHT DOLLARS</u> PER SQUARE YARD	8.00	20,000.00
20 P-101	300 LF	REMOVAL OF PIPE (18" RCP) <u>THIRTY ONE DOLLARS</u> PER LINEAR FOOT	31.00	9300.00

REVISED BID FORM

Bid Proposal Summary For All Work Depicted In The Plans And Specifications

ITEM NO.	APPROX. QUANTITY	ITEM WITH UNIT PRICE WRITTEN IN WORDS	UNIT PRICES IN FIGURES		EXTENDED TOTAL	
			DOLLARS	CENTS	DOLLARS	CENTS
21 P-101	300 LF	REMOVAL OF PIPE (10" PVC) <u>TWENTY SIX DOLLARS</u> PER LINEAR FOOT	26.00		7800.00	
22 P-101	6 EA	REMOVAL OF ENDWALLS <u>SIX HUNDRED DOLLARS</u> PER EACH	600.00		3600.00	
23 P-101	1,500 LF	REMOVAL OF CONDUIT AND CABLE <u>FOUR DOLLARS</u> PER LINEAR FOOT	4.00		6000.00	
24 P-101	2 EA	REMOVAL OF INLETS <u>SEVEN HUNDRED DOLLARS</u> PER EACH	700.00		1400.00	
25 P-101	5 EA	REMOVAL OF MITLS <u>SIXTEEN HUNDRED DOLLARS</u> PER EACH	1600.00		8000.00	
26 P-101	2 EA	REMOVAL OF AIRFIELD GUIDANCE SIGNS <u>THIRTY THREE HUNDRED DOLLARS</u> PER EACH	3300.00		6600.00	
27 P-101	2 EA	REMOVAL OF ELECTRICAL JUNCTION STRUCTURE <u>THIRTY THREE HUNDRED DOLLARS</u> PER EACH	3300.00		6600.00	
28 P-101	1 EA	REMOVAL OF WIND CONE <u>THIRTY FIVE HUNDRED DOLLARS</u> PER EACH	3500.00		3500.00	
29 P-101	150 LF	REMOVAL OF FENCE <u>THIRTEEN DOLLARS</u> PER LINEAR FOOT	13.00		1950.00	
30 P-101	1 LS	PLUG 18" RCP <u>TWO THOUSAND DOLLARS</u> PER LUMP SUM	2000.00		2000.00	

REVISED BID FORM

Bid Proposal Summary For All Work Depicted In The Plans And Specifications

ITEM NO.	APPROX. QUANTITY	ITEM WITH UNIT PRICE WRITTEN IN WORDS	UNIT PRICES	EXTENDED TOTAL
			IN FIGURES	
			DOLLARS	DOLLARS
			CENTS	CENTS
31 P-101	1 LS	CUT AND PLUG 12" SANITARY FORCE MAIN <u>TWO THOUSAND DOLLARS</u> PER LUMP SUM	2000.00	2000.00
32 P-152	11,000 CY	UNCLASSIFIED EXCAVATION <u>SIX DOLLARS AND FIFTY CENTS</u> PER CUBIC YARD	6.50	71,500.00
33 P-152	500 CY	MUCK EXCAVATION <u>THIRTY DOLLARS</u> PER CUBIC YARD	30.00	15,000.00
34 P-154	1,700 CY	SUBBASE COURSE <u>ONE HUNDRED TWENTY FOUR DOLLARS</u> PER CUBIC YARD	124.00	210,800.00
35 P-154	1,800 SY	SEPARATION GEOTEXTILE <u>TWO DOLLARS AND FIFTY CENTS</u> PER SQUARE YARD	2.50	4,500.00
36 P-156	80 TN	CEMENT TWO HUNDRED TWENTY FOUR DOLLARS <u>FIVE HUNDRED DOLLARS</u> PER TON	224.00 500.00	17,920.00 40,000.00
37 P-209	7,000 SY	CRUSHED AGGREGATE BASE COURSE <u>TWENTY TWO DOLLARS</u> PER SQUARE YARD	22.00	154,000.00
38 P-401	2,200 TN	ASPHALT SURFACE COURSE <u>ONE HUNDRED SIXTY NINE DOLLARS</u> PER TON	169.00	371,800.00
39 P-406	100 LF	CRACK REDUCTION MEMBRANE <u>TWENTY EIGHT DOLLARS</u> PER LINEAR FOOT	28.00	2,800.00
40 M-103	2 EA	LIGHTED PORTABLE CLOSED RUNWAY MARKERS <u>TWO THOUSAND FIVE HUNDRED DOLLARS</u> PER EACH	2,500.00	5,000.00

REVISED BID FORM

Bid Proposal Summary For All Work Depicted In The Plans And Specifications

ITEM NO.	APPROX. QUANTITY	ITEM WITH UNIT PRICE WRITTEN IN WORDS	UNIT PRICES IN FIGURES		EXTENDED TOTAL	
			DOLLARS	CENTS	DOLLARS	CENTS
41 M-103	2 EA	CLOSED TAXIWAY MARKERS (CONTRACTOR FURNISHED) <u>TWELVE HUNDRED DOLLARS</u> PER EACH	1200.00		2400.00	
42 M-107	850 LF	AVIATION BARRICADES (CONTRACTOR FURNISHED) <u>THIRTY ONE DOLLARS</u> PER LINEAR FOOT	31.00		26,350.00	
43 P-603	800 GL	EMULSIFIED ASPHALT TACK COAT <u>FOUR DOLLARS</u> PER GALLON	4.00		3200.00	
44 P-620	1,750 SF	MARKING (INITIAL YELLOW) <u>TEN DOLLARS</u> PER SQUARE FOOT	10.00		17,500.00	
45 P-620	1,750 SF	MARKING (PERMANENT YELLOW) <u>FOUR DOLLARS</u> PER SQUARE FOOT	4.00		7000.00	
46 P-620	3,400 SF	MARKING (PERMANENT BLACK) <u>TWO DOLLARS</u> PER SQUARE FOOT	2.00		6800.00	
47 P-620	1 LS	REFLECTIVE MEDIA <u>TWO THOUSAND DOLLARS</u> PER LUMP SUM	2000.00		2000.00	
48 F-162	225 LF	8' GALVANIZED CHAIN-LINK FENCE <u>ONE HUNDRED TEN DOLLARS</u> PER LINEAR FOOT	110.00		24,750.00	
49 D-701	300 LF	15" HDPE PIPE <u>EIGHTY FIVE DOLLARS</u> PER LINEAR FOOT	85.00		25,500.00	
50 D-701	630 LF	18" HDPE PIPE <u>NINETY FOUR DOLLARS</u> PER LINEAR FOOT	94.00		59,220.00	

REVISED BID FORM

Bid Proposal Summary For All Work Depicted In The Plans And Specifications

ITEM NO.	APPROX. QUANTITY	ITEM WITH UNIT PRICE WRITTEN IN WORDS	UNIT PRICES	EXTENDED TOTAL
			IN FIGURES	
			DOLLARS	DOLLARS
			CENTS	CENTS
51 D-701	240 LF	24" HDPE PIPE <u>ONE HUNDRED SEVENTEEN DOLLARS</u> PER LINEAR FOOT	117.00	28,080.00
52 D-701	450 LF	18" RCP, CLASS V <u>SEVENTY DOLLARS</u> PER LINEAR FOOT	70.00	31,500.00
53 D-701	175 LF	24" RCP, CLASS V <u>NINETY FOUR DOLLARS</u> PER LINEAR FOOT	94.00	16,450.00
54 D-705	3,100 LF	6" PVC UNDERDRAIN OR EDGE DRAIN PIPE (PERFORATED) <u>THIRTY ONE DOLLARS</u> PER LINEAR FOOT	31.00	96,100.00
55 D-705	650 LF	6" PVC UNDERDRAIN OR EDGE DRAIN PIPE (SOLID) <u>THIRTY FOUR DOLLARS</u> PER LINEAR FOOT	34.00	22,100.00
56 D-705	23 EA	HEAVY DUTY UNDERDRAIN OR EDGE DRAIN CLEANOUT <u>FOURTEEN HUNDRED DOLLARS</u> PER EACH	1400.00	32,200.00
57 D-751	5 EA	DRAINAGE INLETS <u>THIRTY FIVE HUNDRED DOLLARS</u> PER EACH	3500.00	17,500.00
58 D-751	2 EA	DRAINAGE INLETS, AIRCRAFT RATED <u>SIXTY TWO HUNDRED DOLLARS</u> PER EACH	6200.00	12,400.00
59 D-751	1 EA	RISER STRUCTURE <u>THIRTY THOUSAND DOLLARS</u> PER EACH	30,000.00	30,000.00
60 D-752	1 EA	6" UNDERDRAIN ENDWALL <u>SIX HUNDRED DOLLARS</u> PER EACH	600.00	600.00

REVISED BID FORM

Bid Proposal Summary For All Work Depicted In The Plans And Specifications

ITEM NO.	APPROX. QUANTITY	ITEM WITH UNIT PRICE WRITTEN IN WORDS	UNIT PRICES IN FIGURES		EXTENDED TOTAL	
			DOLLARS	CENTS	DOLLARS	CENTS
61 D-752	1 EA	FES, 18" RCP <u>ELEVEN HUNDRED DOLLARS</u> PER EACH	1100.00		1100.00	
62 D-752	1 EA	FES, 18" HDPE <u>ELEVEN HUNDRED DOLLARS</u> PER EACH	1100.00		1100.00	
63 D-752	1 EA	FES, 24" HDPE <u>FIFTEEN HUNDRED DOLLARS</u> PER EACH	1500.00		1500.00	
64 T-901	13 AC	SEEDING <u>TWENTY FIVE HUNDRED DOLLARS</u> PER ACRE	2500.00		32,500.00	
65 T-908	13 AC	MULCHING <u>EIGHTEEN HUNDRED DOLLARS</u> PER ACRE	1800.00		23,400.00	
66 L-107	1 EA	L-807 I-B SIZE 2 WIND CONE AND FOUNDATION, IN PLACE <u>FORTY THOUSAND DOLLARS</u> PER EACH	40,000.00		40,000.00	
67 L-107	1 LS	SEGMENTED CIRCLE MARKER SYSTEM, IN PLACE <u>FORTY THOUSAND DOLLARS</u> PER LUMP SUM	40,000.00		40,000.00	
68 L-108	8,200 LF	NO. 8 AWG, 5KV, L-824 TYPE C CABLE, INSTALLED IN TRENCH, DUCT BANK OR CONDUIT <u>THREE DOLLARS AND FIFTY CENTS</u> PER LINEAR FOOT	3.50		28,700.00	
69 L-108	2,300 LF	NO. 6 AWG, 600V, L-824 RHW CABLE, INSTALLED IN TRENCH, DUCT BANK OR CONDUIT <u>FOUR DOLLARS AND FORTY CENTS</u> PER LINEAR FOOT	4.40		10,120.00	
70 L-108	5,400 LF	NO. 6 AWG SOLID BARE COPPER COUNTERPOISE WIRE, INSTALLED ABOVE THE DUCT BANK OR CONDUIT, INCLUDING CONNECTIONS/TERMINATIONS <u>TWO DOLLARS AND SIXTY CENTS</u> PER LINEAR FOOT	2.60		14,040.00	

REVISED BID FORM

Bid Proposal Summary For All Work Depicted In The Plans And Specifications

ITEM NO.	APPROX. QUANTITY	ITEM WITH UNIT PRICE WRITTEN IN WORDS	UNIT PRICES IN FIGURES		EXTENDED TOTAL	
			DOLLARS	CENTS	DOLLARS	CENTS
71 L-110	250 LF	CONCRETE ENCASED ELECTRICAL DUCT BANK, 2 WAY - 2" PVC CONDUIT <u>NINETY THREE DOLLARS</u> PER LINEAR FOOT	93.00		23,250.00	
72 L-110	4,300 LF	NON-ENCASED ELECTRICAL CONDUIT, 1 WAY - 2" PVC CONDUIT <u>FOURTEEN DOLLARS</u> PER LINEAR FOOT	14.00		60,200.00	
73 L-110	850 LF	NON-ENCASED ELECTRICAL CONDUIT, 2 WAY - 2" PVC CONDUIT <u>TWENTY TWO DOLLARS</u> PER LINEAR FOOT	22.00		18,700.00	
74 L-115	8 EA	ELECTRICAL JUNCTION STRUCTURE, 2-UNIT L-887 PULLCAN PLAZA <u>NINE THOUSAND DOLLARS</u> PER EACH	9000.00		72,000.00	
75 L-125	8 EA	L-858(L) AIRFIELD GUIDANCE SIGN (3-4 CHAR.) ON NEW FOUNDATION <u>TWELVE THOUSAND DOLLARS</u> PER EACH	12,000.00		96,000.00	
76 L-125	2 EA	AIRFIELD GUIDANCE SIGN PANEL REPLACEMENT <u>FIVE THOUSAND DOLLARS</u> PER EACH	5000.00		10,000.00	
77 L-125	32 EA	L-861T(L) BASE MOUNTED MITL (LED) <u>TWO THOUSAND SIX HUNDRED DOLLARS</u> PER EACH	2600.00		83,200.00	
78 L-125	400 EA	GROUND RODS <u>ONE HUNDRED THIRTY FIVE DOLLARS</u> PER EACH	135.00		54,000.00	
79 R-707	1,150 SY	RIPRAP (CLASS)(TYPE) <u>FIFTY DOLLARS</u> PER SQUARE YARD	50.00		57,500.00	
80 R-908	1,500 SY	SOIL STABILIZATION MAT (CHANNEL) <u>TWO DOLLARS AND FIFTY CENTS</u> PER SQUARE YARD	2.50		3750.00	

REVISED BID FORM

Bid Proposal Summary For All Work Depicted In The Plans And Specifications

ITEM NO.	APPROX. QUANTITY	ITEM WITH UNIT PRICE WRITTEN IN WORDS	UNIT PRICES IN FIGURES		EXTENDED TOTAL	
			DOLLARS	CENTS	DOLLARS	CENTS
81 R-908	2,950 SY	SOIL STABILIZATION MAT (SLOPE) <u>TWO DOLLARS AND FIFTY CENTS</u> PER SQUARE YARD	2.50		7375.00	
82 R-908	400 SY	TURF REINFORCEMENT MATTING <u>FIVE DOLLARS</u> PER SQUARE YARD	5.00		2000.00	
83 SP-41	1 LS	WIND TEE REMOVAL, REFURBISHMENT, AND RELOCATION <u>TWO HUNDRED THOUSAND DOLLARS</u> PER LUMP SUM		200,000.00		200,000.00
84 SP-42	1 LS	TEMPORARY SECURITY FENCE <u>ONE HUNDRED THOUSAND DOLLARS</u> PER LUMP SUM		100,000.00		100,000.00

Total Bid Amount \$ 3,375,555.00

Certification Regarding Federal Contract Language

In addition to the specific Federal Contract Provisions listed within this proposal form, the bidder/offeror certifies by signing and submitting this bid or proposal, that they have read, understand, and will comply with all of the Federal Contract Provisions contained within the project documents as listed by reference and qualified below:

All Contracts Regardless of Funding Source

Civil Rights – General Provisions

Civil Rights – Title VI

All AIP Funded Contracts

Access to Records and Reports

Buy American Preference

Domestic Preferences for Procurements

Federal Fair Labor Standards Act (Minimum Wage)

Foreign Trade Restriction

Occupational Safety and Health Act

Prohibition on Certain Telecommunications and Video Surveillance Services or Equipment

Prohibition of Segregated Facilities

Rights to Inventions

Seismic Safety

Tax Delinquency and Felony Convictions

Veteran's Preference

Additional Provisions for AIP Funded Contracts that are \$2,000 and greater

Copeland Anti-Kickback Act

Davis-Bacon Requirements

Additional Provisions for AIP Funded Contracts that are \$10,000 and greater

Affirmative Action Requirement

Texting Messaging While Driving

Equal Employment Opportunity

Procurement of Recovered Materials

Termination of Contract

Additional Provisions for AIP Funded Contracts that are \$25,000 and greater

Debarment and Suspension

Additional Provisions for AIP Funded Contracts that are \$100,000 and greater

- Breach of Contract (AIP and Non-AIP)
- Clean Air and Water Pollution Controls
- Contract Work Hours and Safety Standards
- Disadvantaged Business Enterprise
- Lobbying Federal Employees

Name of Bidder: Allan Myers MD, Inc.

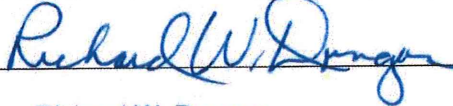
Signature: 

Name: (type or print) Richard W. Dungan

Official Title: President Date: 5/1/24

Certification of Compliance with FAA Buy American Preference

CONSTRUCTION PROJECTS

As a matter of bid responsiveness, the bidder or offeror must complete, sign, date, and submit this certification statement with its proposal. The bidder or offeror must indicate how it intends to comply with 49 USC § 50101, BABA, and other Made in America Laws, U.S. statutes, guidance, and FAA policies by selecting one of the following certification statements. These statements are mutually exclusive. Bidder must SELECT ONE certification statement (not both) by inserting a checkmark (✓) or the letter "X".

- Bidder or offeror hereby certifies that it will comply with 49 USC § 50101, BABA, and other related U.S. statutes, guidance, and policies of the FAA by:
- a) Only installing iron, steel, and manufactured products produced in the United States;
 - b) Only installing construction materials defined as: an article, material, or supply – other than an item of primarily iron or steel; a manufactured product; cement and cementitious materials; aggregates such as stone, sand, or gravel; or aggregate binding agents or additives that are or consist primarily of non-ferrous metals; plastic and polymer-based products (including polyvinylchloride, composite building materials, and polymers used in fiber optic cables); glass (including optic glass); lumber or drywall that have been manufactured in the United States.
 - c) Installing manufactured products for which the Federal Aviation Administration (FAA) has issued a waiver as indicated by inclusion on the current FAA Nationwide Buy American Waivers Issued listing; or
 - d) Installing products listed as an Excepted Article, Material or Supply in Federal Acquisition Regulation Subpart 25.108.

By selecting this certification statement, the bidder or offeror agrees:

- a) To provide to the Airport Sponsor or the FAA evidence that documents the source and origin of the iron, steel, and/or manufactured product.
- b) To faithfully comply with providing U.S. domestic products.
- c) To refrain from seeking a waiver request after establishment of the contract, unless extenuating circumstances emerge that the FAA determines justified.
- d) Certify that all construction materials used in the project are manufactured in the U.S.

- Bidder or offeror hereby certifies it cannot comply with the 100 percent Buy American Preferences of 49 USC § 50101(a) but may qualify for a Type 3 or Type 4 waiver under 49 USC § 50101(b). By selecting this certification statement, the apparent bidder or offeror with the apparent low bid agrees:

- a) To submit to the Airport Sponsor or FAA within 15 calendar days of being selected as the responsive bidder, a formal waiver request and required documentation that supports the type of waiver being requested.
- b) That failure to submit the required documentation within the specified timeframe is cause for a non-responsive determination that may result in rejection of the proposal.

- c) To faithfully comply with providing U.S. domestic products at or above the approved U.S. domestic content percentage as approved by the FAA.
- d) To furnish U.S. domestic product for any waiver request that the FAA rejects.
- e) To refrain from seeking a waiver request after establishment of the contract, unless extenuating circumstances emerge that the FAA determines justified.

REQUIRED DOCUMENTATION

Type 2 Waiver (Nonavailability) – The iron, steel, manufactured goods or construction materials or manufactured goods are not available in sufficient quantity or quality in the United States. The required documentation for the Nonavailability waiver is:

- a) Completed Content Percentage Worksheet and Final Assembly Questionnaire
- b) Record of thorough market research, consideration where appropriate of qualifying alternate items, products, or materials including;
- c) A description of the market research activities and methods used to identify domestically manufactured items capable of satisfying the requirement, including the timing of the research and conclusions reached on the availability of sources.

Type 3 Waiver – The cost of components and subcomponents produced in the United States is more than 60 percent of the cost of all components and subcomponents of the “facility/project.” The required documentation for a Type 3 waiver is:

- a) Completed Content Percentage Worksheet and Final Assembly Questionnaire including;
- b) Listing of all manufactured products that are not comprised of 100 percent U.S. domestic content (excludes products listed on the FAA Nationwide Buy American Waivers Issued listing and products excluded by Federal Acquisition Regulation Subpart 25.108; products of unknown origin must be considered as non-domestic products in their entirety).
- c) Cost of non-domestic components and subcomponents, excluding labor costs associated with final assembly and installation at project location.
- d) Percentage of non-domestic component and subcomponent cost as compared to total “facility” component and subcomponent costs, excluding labor costs associated with final assembly and installation at project location.

Type 4 Waiver (Unreasonable Costs) – Applying this provision for iron, steel, manufactured goods or construction materials would increase the cost of the overall project by more than 25 percent. The required documentation for this waiver is:

- a) A completed Content Percentage Worksheet and Final Assembly Questionnaire from
- b) At minimum two comparable equal bids and/or offers;
- c) Receipt or record that demonstrates that supplier scouting called for in Executive Order 14005, indicates that no domestic source exists for the project and/or component;
- d) Completed waiver applications for each comparable bid and/or offer.

FALSE STATEMENTS

Per 49 USC § 47126, this certification concerns a matter within the jurisdiction of the Federal Aviation Administration and the making of a false, fictitious, or fraudulent certification may render the maker subject to prosecution under Title 18, United States Code.

5/1/24
Date

Richard W. Dungen
Signature

Allan Myers MD, Inc.
Company Name

President
Title

Certifications Regarding Debarment

CERTIFICATION OF OFFEROR/BIDDER REGARDING DEBARMENT

(2 CFR Part 180 (subpart B); 2 CFR Part 200, Appendix II(H); 2 CFR Part 1200; DOT Order 4200.5; Executive Orders 12549 and 12689)

By submitting a bid/proposal under this solicitation, the bidder or offeror certifies that neither it nor its principals are presently debarred or suspended by any Federal department or agency from participation in this transaction.

CERTIFICATION OF LOWER TIER CONTRACTORS REGARDING DEBARMENT

The successful bidder, by administering each lower tier subcontract that exceeds \$25,000 as a "covered transaction", must confirm each lower tier participant of a "covered transaction" under the project is not presently debarred or otherwise disqualified from participation in this federally assisted project. The successful bidder will accomplish this by:

- (1) Checking the System for Award Management at website: <http://www.sam.gov>.
- (2) Collecting a certification statement similar to the Certification of Offeror/Bidder Regarding Debarment, above.
- (3) Inserting a clause or condition in the covered transaction with the lower tier contract.

If the Federal Aviation Administration later determines that a lower tier participant failed to disclose to a higher tier participant that it was excluded or disqualified at the time it entered the covered transaction, the FAA may pursue any available remedies, including suspension and debarment of the non-compliant participant.

Name of Bidder: Allan Myers MD, Inc.

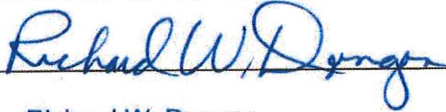
Signature: 

Name: (type or print) Richard W. Dungan

Official Title: President Date: 5/1/24

Certification Regarding Lobbying

(31 USC Par 1352 – Byrd Anti-Lobbying Amendment; 2 CFR Part 200, Appendix II(I); 49 CFR Part 20, Appendix A)

The Bidder or Offeror certifies by signing and submitting this bid or proposal, to the best of his or her knowledge and belief, that:

- (1) No Federal appropriated funds have been paid or will be paid, by or on behalf of the Bidder or Offeror, to any person for influencing or attempting to influence an officer or employee of an agency, a Member of Congress, an officer or employee of Congress, or an employee of a Member of Congress in connection with the awarding of any Federal contract, the making of any Federal grant, the making of any Federal loan, the entering into of any cooperative agreement, and the extension, continuation, renewal, amendment, or modification of any Federal contract, grant, loan, or cooperative agreement.
- (2) If any funds other than Federal appropriated funds have been paid or will be paid to any person for influencing or attempting to influence an officer or employee of any agency, a Member of Congress, an officer or employee of Congress, or an employee of a Member of Congress in connection with this Federal contract, grant, loan, or cooperative agreement, the undersigned shall complete and submit Standard Form-LLL, "Disclosure Form to Report Lobbying," in accordance with its instructions.
- (3) The undersigned shall require that the language of this certification be included in the award documents for all sub-awards at all tiers (including subcontracts, subgrants, and contracts under grants, loans, and cooperative agreements) and that all sub-recipients shall certify and disclose accordingly.

This certification is a material representation of fact upon which reliance was placed when this transaction was made or entered into. Submission of this certification is a prerequisite for making or entering into this transaction imposed by section 1352, title 31, U.S. Code. Any person who fails to file the required certification shall be subject to a civil penalty of not less than \$10,000 and not more than \$100,000 for each such failure.

Name of Bidder: Allan Myers MD, Inc.

Signature: 

Name: (type or print) Richard W. Dungan

Official Title: President

Date: 5/1/24

Certification Regarding Trade Restriction

(49 USC Par 50104; 49 CFR Part 30)

By submission of an offer, the Offeror certifies that with respect to this solicitation and any resultant contract, the Offeror –

- (1) is not owned or controlled by one or more citizens of a foreign country included in the list of countries that discriminate against U.S. firms as published by the Office of the United States Trade Representative (USTR);
- (2) has not knowingly entered into any contract or subcontract for this project with a person that is a citizen or national of a foreign country included on the list of countries that discriminate against U.S. firms as published by the USTR; and
- (3) has not entered into any subcontract for any product to be used on the Federal project that is produced in a foreign country included on the list of countries that discriminate against U.S. firms published by the USTR.

This certification concerns a matter within the jurisdiction of an agency of the United States of America and the making of a false, fictitious, or fraudulent certification may render the maker subject to prosecution under Title 18 USC § 1001.

The Offeror/Contractor must provide immediate written notice to the Owner if the Offeror/Contractor learns that its certification or that of a subcontractor was erroneous when submitted or has become erroneous by reason of changed circumstances. The Contractor must require subcontractors to provide immediate written notice to the Contractor if at any time it learns that its certification was erroneous by reason of changed circumstances.

Unless the restrictions of this clause are waived by the Secretary of Transportation in accordance with 49 CFR § 30.17, no contract shall be awarded to an Offeror or subcontractor:

- (1) who is owned or controlled by one or more citizens or nationals of a foreign country included on the list of countries that discriminate against U.S. firms published by the USTR; or
- (2) whose subcontractors are owned or controlled by one or more citizens or nationals of a foreign country on such USTR list; or
- (3) who incorporates in the public works project any product of a foreign country on such USTR list.

Nothing contained in the foregoing shall be construed to require establishment of a system of records in order to render, in good faith, the certification required by this provision. The knowledge and information of a contractor is not required to exceed that which is normally possessed by a prudent person in the ordinary course of business dealings.

The Offeror agrees that, if awarded a contract resulting from this solicitation, it will incorporate this provision for certification without modification in all lower tier subcontracts. The Contractor may rely on the certification of a prospective subcontractor that it is not a firm from a foreign country included on the

list of countries that discriminate against U.S. firms as published by USTR, unless the Offeror has knowledge that the certification is erroneous.

This certification is a material representation of fact upon which reliance was placed when making an award. If it is later determined that the Contractor or subcontractor knowingly rendered an erroneous certification, the Federal Aviation Administration (FAA) may direct through the Owner cancellation of the contract or subcontract for default at no cost to the Owner or the FAA.

Name of Bidder: Allan Myers MD, Inc.

Signature: 

Name: (type or print) Richard W. Dungan

Official Title: President

Date: 5/1/24

Certification of Offeror/Bidder Regarding Tax Delinquency and Felony Convictions

The applicant must complete the following two certification statements. The applicant must indicate its current status as it relates to tax delinquency and felony conviction by inserting a checkmark () in the space following the applicable response. The applicant agrees that, if awarded a contract resulting from this solicitation, it will incorporate this provision for certification in all lower tier subcontracts.

Certifications

- (1) The applicant represents that it is () is not () a corporation that has any unpaid Federal tax liability that has been assessed, for which all judicial and administrative remedies have been exhausted or have lapsed, and that is not being paid in a timely manner pursuant to an agreement with the authority responsible for collecting the tax liability.
- (2) The applicant represents that it is () is not () a corporation that was convicted of a criminal violation under any Federal law within the preceding 24 months.

Note

If an applicant responds in the affirmative to either of the above representations, the applicant is ineligible to receive an award unless the Sponsor has received notification from the agency suspension and debarment official (SDO) that the SDO has considered suspension or debarment and determined that further action is not required to protect the Government's interests. The applicant therefore must provide information to the owner about its tax liability or conviction to the Owner, who will then notify the FAA Airports District Office, which will then notify the agency's SDO to facilitate completion of the required considerations before award decisions are made.

Term Definitions

Felony conviction: Felony conviction means a conviction within the preceding twenty four (24) months of a felony criminal violation under any Federal law and includes conviction of an offense defined in a section of the U.S. Code that specifically classifies the offense as a felony and conviction of an offense that is classified as a felony under 18 USC § 3559.

Tax Delinquency: A tax delinquency is any unpaid Federal tax liability that has been assessed, for which all judicial and administrative remedies have been exhausted, or have lapsed, and that is not being paid in a timely manner pursuant to an agreement with the authority responsible for collecting the tax liability.

Name of Bidder: Allan Myers MD, Inc.

Signature: 

Name: (type or print) Richard W. Dungan

Official Title: President Date: 5/1/24

Disadvantaged Business Enterprise Utilization

The undersigned has satisfied the requirements of the specifications in the following manner (please check the appropriate space):

The bidder is committed to a minimum of 12.48% DBE utilization on this project.

The bidder (if unable to meet the goal of 12.48% DBE utilization) is committed to a minimum of _____% DBE utilization on this project and has submitted documentation showing good faith effort.

Name of Bidder: Allan Myers MD, Inc.

Signature: 

Name: (type or print) Richard W. Dungan

Official Title: President

Date: 5/1/24

DBE Letter of Intent

Name of Bidder: Allan Myers MD, Inc.

Bidder's Address: P.O. Box 278 / 2011 Belair Road

City: Fallston State: MD Zip: 21047

Name of Subcontracted DBE Firm: Tegeler Construction & Supply

Delaware DBE Certification #: 2139

Firm's Address: 1900 Finishing Mill Rd. Ste 100

City: Sparrows Point State: MD Zip: 21219

Telephone: (443) 990-033 Email: britt@tegelercs.com

Disadvantaged Group: DELDOT DBE #2139, DELDOT SBF #SBF18061198, DELDOT WBE #DE18062993

Description of work to be performed by the DBE firm:

Furnish Material

NAICS Code(s) associated with work listed above: 423320

Bidder/offeror intends to utilize the above-named DBE firm for the work described above.

The estimated amount of work is valued at \$ _____.

Materials providers value at \$ 235,000.00 x 60% = \$141,000.00

(Amount to be used in DBE Participation Calculation)

AFFIRMATION

The above-named subcontracted DBE firm affirms that it will perform the portion of the contract for the estimated dollar value as stated above.

By: Britt Arnold President 4/26/2024
Subcontractor Signature Title Date

If the above-named bidder is not determined to be the successful bidder, the Letter of Intent shall be null and void.

Copy this Letter of Intent for each DBE subcontractor and for each Bid Alternate (if applicable)

DBE Letter of Intent

Name of Bidder: Allan Myers MD, INC
Bidder's Address: P.O. Box 278 / 2011 Belair Rd.
City: Fallston State: MD Zip: 21047

Name of Subcontracted DBE Firm: Atlantic Surveying & Mapping, L.L.C.

Delaware DBE Certification #: C-1021

Firm's Address: P.O. Box 734

City: Georgetown State: DE Zip: 19947

Telephone: (302) 684-2980 Email: mary.asm@comcast.net

Disadvantaged Group: WBE

Description of work to be performed by the DBE firm:

- Construction Layout
- As-Built Surveys
- Topography

NAICS Code(s) associated with work listed above: 541370

Bidder/offeror intends to utilize the above-named DBE firm for the work described above.

The estimated amount of work is valued at \$ 62,000.00.

Materials providers value at \$ _____ x 60% = _____
(Amount to be used in DBE Participation Calculation)

DBE Letter of Intent

Name of Bidder: Allan Myers MD, Inc.
Bidder's Address: P.O. Box 278/2011 Belair Rd
City: Fallston State: MD Zip: 21047

Name of Subcontracted DBE Firm: Seagull Fence LLC

Delaware DBE Certification #: 943

Firm's Address: 30143 Discount Lane Road

City: Laurel State: DE Zip: 19956

Telephone: (302) 956-0417 Email: jr@seagullfence.com

Disadvantaged Group: MBE/DBE

Description of work to be performed by the DBE firm:

Chain link fence

NAICS Code(s) associated with work listed above: 238990

Bidder/offeror intends to utilize the above-named DBE firm for the work described above.

The estimated amount of work is valued at \$ 43,000.00.

Materials providers value at \$ _____ x 60% = _____
(Amount to be used in DBE Participation Calculation)

AFFIRMATION

The above-named subcontracted DBE firm affirms that it will perform the portion of the contract for the estimated dollar value as stated above.

By: Ja Villada Sales & Estimating 04/30/24
Subcontractor Signature Title Date

If the above-named bidder is not determined to be the successful bidder, the Letter of Intent shall be null and void.

Copy this Letter of Intent for each DBE subcontractor and for each Bid Alternate (if applicable)

DBE Letter of Intent

Name of Bidder: Allan Myers MD, Inc.

Bidder's Address: P.O. Box 278 / 2011 Belair Road

City: Fallston State: MD Zip: 21047

Name of Subcontracted DBE Firm: Site Services, LLC

Delaware DBE Certification #: 2251

Firm's Address: 2231 Congwingo Rd Ste. C

City: Bel Air State: MD Zip: 21015

Telephone: (410) 645-1864 Email: _____

Disadvantaged Group: WBE

Description of work to be performed by the DBE firm:

Erosion Controls, Seeding

NAICS Code(s) associated with work listed above: 561730

Bidder/offeror intends to utilize the above-named DBE firm for the work described above.

The estimated amount of work is valued at \$ 176,000.00

Materials providers value at \$ _____ x 60% = _____

(Amount to be used in DBE Participation Calculation)

AFFIRMATION

The above-named subcontracted DBE firm affirms that it will perform the portion of the contract for the estimated dollar value as stated above.

By: [Signature] Project Admin 4/26/24
Subcontractor Signature Title Date

If the above-named bidder is not determined to be the successful bidder, the Letter of Intent shall be null and void.

Copy this Letter of Intent for each DBE subcontractor and for each Bid Alternate (if applicable)

Subcontractor List

All Companies performing work for this project are listed below.

Company		Contract		Certified DBE (Y/N)*
Name	BW Electric	Amount	\$450,000.00	N
Address	15342 S Dupont HWY Harrington, DE 199523	Work to Be Performed	Electrical	
Name	Atlantic Surveying and Mapping, LLC.	Amount	\$62,000.00	Y
Address	P.O. Box 734 Georgetown, DE 19947	Work to Be Performed	Survey / Stakeout	
Name	Site Services	Amount	\$176,000.00	Y
Address	2231 Conowingo Rd Bel Air, MD 21015	Work to Be Performed	Erosion Control	
Name	Zone Striping, Inc.	Amount	\$25,000.00	N
Address	P.O. Box 568 Glassboro, NJ 08028	Work to Be Performed	Striping	
Name	Seagull Fence LLC	Amount	\$43,000.00	Y
Address	30143 Discount Land Rd Laurel, DE 19956	Work to Be Performed	Fencing	

*Indicate "Y" only for Certified DBE in Delaware.

Name of Bidder: Allan Myers MD, Inc.

Consent to Extend Date by Which Contract Will Be Awarded

Bidder is hereby advised that in light of the time frame of the grant application and approval process, the actual contract award is not likely to be made until 180 days after bid opening.

Accordingly, each bidder is requested to affirmatively state that, if Bidder is deemed to be the lowest responsible Bidder, Bidder consents to extending the period by which the award will be made to 180 days after bid opening.

Bidder affirmatively states that, if Bidder is the lowest responsible bidder, Bidder
(Yes) (No) hereby consents to extending the period by which the award may be made to 180 days after bid opening.

This Consent does not preclude the Owner from later requesting Bidder to consent to have its bid held for consideration for a longer period than 180 days.

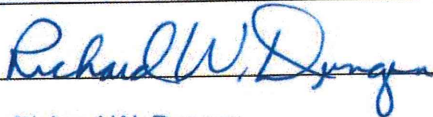
Bidder: Allan Myers MD, Inc.
Signature: 
Name: Richard W. Dungan
Date: 5/1/24

Bid Bond

Policy Number: N/A

Effective Date: May 1, 2024

KNOW ALL MEN BY THESE PRESENTS, THAT WE,

 ALLAN MYERS MD, INC. , as Principal, hereinafter called the Principal, and
 FIDELITY AND DEPOSIT COMPANY OF MARYLAND , a corporation duly organized under the laws of
the State of Illinois , as Surety, hereinafter called the Surety, are held and firmly
bound unto Sussex County Council, hereinafter called the Obligee, in the sum of
Ten Percent of the Base Bid Plus the Total Amount of All
 Additive Alternates ~~Excludes~~ (\$ 10%) for the
payment of which sum well and truly to be made, the said Principal and the said Surety, bind ourselves,
our heirs, executors, administrators, successors and assigns, jointly and severally, firmly by these
presents.

WHEREAS, the Principal has submitted a bid for the project Construct Taxiway B - Bid Package 1 and
associated items for work at the Delaware Coastal Airport in accordance with Plans and Specifications
prepared by Delta Airport Consultants, Inc., 3544 North Progress Ave., Suite 200, Harrisburg,
Pennsylvania 17110, Telephone: (717) 652-8700, Fax: (717) 652-8371.

NOW, THEREFORE, if the Obligee shall accept the bid of the Principal and the Principal shall enter into
a Contract with the Obligee in accordance with the terms of such bid, and give such bond or bonds as may
be specified in the bidding or Contract Documents with good and sufficient surety for the faithful
performance of such Contract and for the prompt payment of labor and material furnished in the
prosecution thereof, or in the event of the failure of the principal to enter such Contract and give such
bond or bonds, if the Principal shall pay to the Obligee the difference not to exceed the penalty hereof
between the amount specified in said bid and such larger amount for which the Obligee may in good faith
contract with another party to perform the Work covered by said bid, then this obligation shall be null and
void, otherwise to remain in full force and effect.

Signed and sealed this 1st day of May 2024.

ALLAN MYERS MD, INC.

(Principal)

(Seal)

Richard W. Dwyer
(Title) President

[Signature]
(Witness)

FIDELITY AND DEPOSIT COMPANY OF MARYLAND

(Surety)

(Seal)

[Signature]
(Title) Elizabeth P. Cervini, Attorney-in-Fact

Cindy Walsh
(Witness) Cindy Walsh, Witness

**ZURICH AMERICAN INSURANCE COMPANY
COLONIAL AMERICAN CASUALTY AND SURETY COMPANY
FIDELITY AND DEPOSIT COMPANY OF MARYLAND
POWER OF ATTORNEY**

KNOW ALL MEN BY THESE PRESENTS: That the ZURICH AMERICAN INSURANCE COMPANY, a corporation of the State of New York, the COLONIAL AMERICAN CASUALTY AND SURETY COMPANY, a corporation of the State of Illinois, and the FIDELITY AND DEPOSIT COMPANY OF MARYLAND a corporation of the State of Illinois (herein collectively called the "Companies"), by Robert D. Murray, Vice President, in pursuance of authority granted by Article V, Section 8, of the By-Laws of said Companies, which are set forth on the reverse side hereof and are hereby certified to be in full force and effect on the date hereof, do hereby nominate, constitute, and appoint **Melissa J. HINDE, James M. DISCIULLO, John E. ROSENBERG, Harry C. ROSENBERG, Elizabeth P. CERVINI, David C. ROSENBERG, Matthew J. ROSENBERG, Denise M. BRUNO, Julia R. BURNET, Elizabeth B. PENDLETON, Jonathan F. BLACK, David A. JOHNSON, Stephanie S. HELMIG**, all of Wayne, Pennsylvania, its true and lawful agent and Attorney-in-Fact, to make, execute, seal and deliver, for, and on its behalf as surety, and as its act and deed: any and all **bonds and undertakings**, and the execution of such bonds or undertakings in pursuance of these presents, shall be as binding upon said Companies, as fully and amply, to all intents and purposes, as if they had been duly executed and acknowledged by the regularly elected officers of the ZURICH AMERICAN INSURANCE COMPANY at its office in New York, New York., the regularly elected officers of the COLONIAL AMERICAN CASUALTY AND SURETY COMPANY at its office in Owings Mills, Maryland., and the regularly elected officers of the FIDELITY AND DEPOSIT COMPANY OF MARYLAND at its office in Owings Mills, Maryland., in their own proper persons.

The said Vice President does hereby certify that the extract set forth on the reverse side hereof is a true copy of Article V, Section 8, of the By-Laws of said Companies, and is now in force.

IN WITNESS WHEREOF, the said Vice-President has hereunto subscribed his/her names and affixed the Corporate Seals of the said ZURICH AMERICAN INSURANCE COMPANY, COLONIAL AMERICAN CASUALTY AND SURETY COMPANY, and FIDELITY AND DEPOSIT COMPANY OF MARYLAND, this 3rd day of October, A.D. 2023.



ATTEST:
**ZURICH AMERICAN INSURANCE COMPANY
COLONIAL AMERICAN CASUALTY AND SURETY COMPANY
FIDELITY AND DEPOSIT COMPANY OF MARYLAND**

By: *Robert D. Murray*
Vice President

By: *Dawn E. Brown*
Secretary

**State of Maryland
County of Baltimore**

On this 3rd day of October A.D. 2023, before the subscriber, a Notary Public of the State of Maryland, duly commissioned and qualified, **Robert D. Murray, Vice President and Dawn E. Brown, Secretary** of the Companies, to me personally known to be the individuals and officers described in and who executed the preceding instrument, and acknowledged the execution of same, and being by me duly sworn, deposed and saith, that he/she is the said officer of the Company aforesaid, and that the seals affixed to the preceding instrument are the Corporate Seals of said Companies, and that the said Corporate Seals and the signature as such officer were duly affixed and subscribed to the said instrument by the authority and direction of the said Corporations.

IN TESTIMONY WHEREOF, I have hereunto set my hand and affixed my Official Seal the day and year first above written.

Genevieve M. Maison

**GENEVIEVE M. MAISON
NOTARY PUBLIC
BALTIMORE COUNTY, MD
My Commission Expires JANUARY 27, 2025**



Authenticity of this bond can be confirmed at bondvalidator.zurichna.com or 410-559-8790

EXTRACT FROM BY-LAWS OF THE COMPANIES

"Article V, Section 8, Attorneys-in-Fact. The Chief Executive Officer, the President, or any Executive Vice President or Vice President may, by written instrument under the attested corporate seal, appoint attorneys-in-fact with authority to execute bonds, policies, recognizances, stipulations, undertakings, or other like instruments on behalf of the Company, and may authorize any officer or any such attorney-in-fact to affix the corporate seal thereto; and may with or without cause modify or revoke any such appointment or authority at any time."

CERTIFICATE

I, the undersigned, Vice President of the ZURICH AMERICAN INSURANCE COMPANY, the COLONIAL AMERICAN CASUALTY AND SURETY COMPANY, and the FIDELITY AND DEPOSIT COMPANY OF MARYLAND, do hereby certify that the foregoing Power of Attorney is still in full force and effect on the date of this certificate; and I do further certify that Article V, Section 8, of the By-Laws of the Companies is still in force.

This Power of Attorney and Certificate may be signed by facsimile under and by authority of the following resolution of the Board of Directors of the ZURICH AMERICAN INSURANCE COMPANY at a meeting duly called and held on the 15th day of December 1998.

RESOLVED: "That the signature of the President or a Vice President and the attesting signature of a Secretary or an Assistant Secretary and the Seal of the Company may be affixed by facsimile on any Power of Attorney...Any such Power or any certificate thereof bearing such facsimile signature and seal shall be valid and binding on the Company."

This Power of Attorney and Certificate may be signed by facsimile under and by authority of the following resolution of the Board of Directors of the COLONIAL AMERICAN CASUALTY AND SURETY COMPANY at a meeting duly called and held on the 5th day of May, 1994, and the following resolution of the Board of Directors of the FIDELITY AND DEPOSIT COMPANY OF MARYLAND at a meeting duly called and held on the 10th day of May, 1990.

RESOLVED: "That the facsimile or mechanically reproduced seal of the company and facsimile or mechanically reproduced signature of any Vice-President, Secretary, or Assistant Secretary of the Company, whether made heretofore or hereafter, wherever appearing upon a certified copy of any power of attorney issued by the Company, shall be valid and binding upon the Company with the same force and effect as though manually affixed.

IN TESTIMONY WHEREOF, I have hereunto subscribed my name and affixed the corporate seals of the said Companies, this 1st day of May, 2024.



MJ Pethick

By: Mary Jean Pethick
Vice President

TO REPORT A CLAIM WITH REGARD TO A SURETY BOND, PLEASE SUBMIT A COMPLETE DESCRIPTION OF THE CLAIM INCLUDING THE PRINCIPAL ON THE BOND, THE BOND NUMBER, AND YOUR CONTACT INFORMATION TO:

Zurich Surety Claims
1299 Zurich Way
Schaumburg, IL 60196-1056
reportsfclaims@zurichna.com
800-626-4577

Authenticity of this bond can be confirmed at bondvalidator.zurichna.com or 410-559-8790

ENGINEERING DEPARTMENT

ADMINISTRATION (302) 855-7718
AIRPORT & BUSINESS PARK (302) 855-7774
ENVIRONMENTAL SERVICES (302) 855-7730
RECORDS MANAGEMENT (302) 855-5033
UTILITY ENGINEERING (302) 855-7717
UTILITY PERMITS (302) 855-7719
UTILITY PLANNING (302) 855-1299
FAX (302) 855-7773

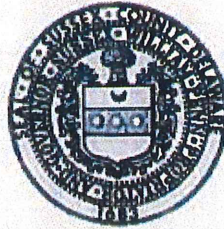

Sussex County

DELAWARE
sussexcountyde.gov

MIKE HARMER, P.E.
SUSSEX COUNTY ENGINEER
ROBERT L. BRYANT, A.A.E.
AIRPORT MANAGER

October 17, 2024

Richard W. Dungan
Allan Myers MD, Inc.
2011 Belair Road
Fallston, MD. 21047

RE: CONSTRUCT TAXIWAY B – BID PACKAGE 1
CONTRACT AWARD EXTENSION

Dear Mr. Dungan:

Allan Myers MD, Inc., is the low bidder for the Construct Taxiway B Project. Sussex County has received, and has accepted from the Federal Aviation Administration, an Airport Improvement Program grant that includes funding associated with your \$3,375,555.00 Construct Taxiway B – Bid Package 1 project bid.

Bid Documents required each bidder to hold their project bid for 180-days past the May 1, 2024, bid opening. That 180-days period would end on October 28, 2024. Considering the time taken to receive and accept from the Federal Aviation Administration an Airport Improvement Program grant, Sussex County is asking you if Allan Myers MD, Inc., can hold their \$3,375,555.00 for bid for one (1) extended day when on October 29, 2024, Sussex County will approve your bid of \$3,375,555.00 and authorize a Notice of Award. If you're in agreement for a delay award of one (1) day, please sign your acceptance below.

Sincerely,

Robert L. Bryant, A.A.E.
Airport Manager

ACCEPTANCE OF BID AWARD EXTENSION

Acceptance of the above Bid Award Extension is hereby acknowledged by:

ALLAN MYERS MD, INC.

This the 17th day of October 2024

By:

Richard W. Dungan

COUNTY ADMINISTRATIVE OFFICES
2 THE CIRCLE | PO BOX 589
GEORGETOWN, DELAWARE 19947

BID TABULATION

Construct Taxiway B - Bid Package 1

Delaware Coastal Airport
Georgetown, Delaware

AIP Project No. 3-10-0007-040-2023 (Design)
AIP Project No. 3-10-0007-Pending (Construction)
Delta Project No. 22033

Bid Opening Date: May 1, 2024

Item No.	Spec. No.	Description	Unit	Bid Quantity	Engineer's Estimate		Allan Myers MD, Inc.		George & Lynch, Inc.		Atlantic Contracting & Material Co., Inc.	
					Unit Price	Estimate Amount	Unit Price	Bid Amount	Unit Price	Bid Amount	Unit Price	Bid Amount
1	C-100	CONTRACTOR QUALITY CONTROL PROGRAM	LS	1	\$300,000.00	\$300,000.00	\$443,320.00	\$443,320.00	\$350,000.00	\$350,000.00	\$398,000.00	\$398,000.00
2	C-102	INSTALLATION AND REMOVAL OF SILT FENCE	LF	3,200	\$3.00	\$9,600.00	\$3.00	\$9,600.00	\$3.93	\$12,576.00	\$5.00	\$16,000.00
3	C-102	INSTALLATION AND REMOVAL OF SUPER SILT FENCE	LF	300	\$5.00	\$1,500.00	\$12.00	\$3,600.00	\$15.73	\$4,719.00	\$20.00	\$6,000.00
4	C-102	STONE CONSTRUCTION ENTRANCE	EA	4	\$5,000.00	\$20,000.00	\$6,000.00	\$24,000.00	\$5,566.00	\$22,264.00	\$8,572.00	\$34,288.00
5	C-102	STONE CHECK DAM	EA	3	\$1,200.00	\$3,600.00	\$1,800.00	\$5,400.00	\$1,950.00	\$5,850.00	\$1,070.00	\$3,210.00
6	C-102	INLET PROTECTION	EA	14	\$250.00	\$3,500.00	\$400.00	\$5,600.00	\$564.00	\$7,896.00	\$977.00	\$13,678.00
7	C-102	CULVERT INLET PROTECTION	EA	2	\$300.00	\$600.00	\$500.00	\$1,000.00	\$904.00	\$1,808.00	\$140.00	\$280.00
8	C-102	COMPOST FILTER LOG	LF	750	\$6.50	\$4,875.00	\$11.00	\$8,250.00	\$17.00	\$12,750.00	\$22.00	\$16,500.00
9	C-102	ORANGE CONSTRUCTION FENCE	LF	2,150	\$6.45	\$13,967.50	\$3.00	\$6,450.00	\$3.30	\$7,085.00	\$5.00	\$10,750.00
10	C-102	SKIMMER DEWATERING DEVICE	EA	2	\$750.00	\$1,500.00	\$3,000.00	\$6,000.00	\$2,950.00	\$5,900.00	\$1,200.00	\$2,400.00
11	C-102	NO. 57 STONE	TN	280	\$125.00	\$35,000.00	\$85.00	\$23,800.00	\$5,438.00	\$1,522,640.00	\$81.00	\$22,680.00
12	C-102	TEMPORARY SEEDING	AC	7	\$1,800.00	\$12,600.00	\$2,000.00	\$14,000.00	\$3,000.00	\$21,000.00	\$6,835.00	\$47,845.00
13	C-105	MOBILIZATION	LS	1	\$270,000.00	\$270,000.00	\$330,000.00	\$330,000.00	\$380,000.00	\$380,000.00	\$131,000.00	\$131,000.00
14	P-101	BITUMINOUS PAVEMENT REMOVAL	SY	150	\$15.00	\$2,250.00	\$12.00	\$1,800.00	\$49.00	\$7,350.00	\$23.00	\$3,450.00
15	P-101	CONCRETE PAVEMENT REMOVAL (6"DEPTH)	SY	1,500	\$25.00	\$37,500.00	\$40.00	\$60,000.00	\$34.50	\$51,750.00	\$39.00	\$58,500.00
16	P-101	CONCRETE PAVEMENT REMOVAL (FULL DEPTH)	SY	125	\$500.00	\$62,500.00	\$148.00	\$18,500.00	\$312.00	\$39,000.00	\$115.00	\$14,375.00
17	P-101	JOINT AND CRACK REPAIR (TYPE A)	LF	600	\$10.00	\$6,000.00	\$18.00	\$10,800.00	\$20.50	\$12,300.00	\$37.00	\$22,200.00
18	P-101	JOINT AND CRACK REPAIR (TYPE B)	LF	400	\$10.00	\$4,000.00	\$18.00	\$7,200.00	\$20.50	\$8,200.00	\$37.00	\$14,800.00
19	P-101	COLD MILLING (2" DEPTH)	SY	2,500	\$5.00	\$12,500.00	\$8.00	\$20,000.00	\$11.05	\$27,625.00	\$15.00	\$37,500.00
20	P-101	REMOVAL OF PIPE (18" RCP)	LF	300	\$20.00	\$6,000.00	\$31.00	\$9,300.00	\$35.55	\$10,665.00	\$50.00	\$15,000.00
21	P-101	REMOVAL OF PIPE (10" PVC)	LF	300	\$15.00	\$4,500.00	\$26.00	\$7,800.00	\$36.25	\$10,875.00	\$42.00	\$12,600.00
22	P-101	REMOVAL OF ENDWALLS	EA	6	\$500.00	\$3,000.00	\$600.00	\$3,600.00	\$1,185.00	\$7,110.00	\$5,613.00	\$33,678.00
23	P-101	REMOVAL OF CONDUIT AND CABLE	LF	1,500	\$5.00	\$7,500.00	\$4.00	\$6,000.00	\$3.21	\$4,815.00	\$5.00	\$7,500.00
24	P-101	REMOVAL OF INLETS	EA	2	\$1,200.00	\$2,400.00	\$700.00	\$1,400.00	\$1,387.00	\$2,774.00	\$3,019.00	\$6,038.00
25	P-101	REMOVAL OF MITLS	EA	5	\$500.00	\$2,500.00	\$1,600.00	\$8,000.00	\$1,605.00	\$8,025.00	\$2,119.00	\$10,595.00
26	P-101	REMOVAL OF AIRFIELD GUIDANCE SIGNS	EA	2	\$1,000.00	\$2,000.00	\$3,300.00	\$6,600.00	\$3,210.00	\$6,420.00	\$4,237.00	\$8,474.00
27	P-101	REMOVAL OF ELECTRICAL JUNCTION STRUCTURE	EA	2	\$2,500.00	\$5,000.00	\$3,500.00	\$7,000.00	\$5,350.00	\$10,700.00	\$7,061.00	\$14,122.00
28	P-101	REMOVAL OF WIND CONE	EA	1	\$2,500.00	\$2,500.00	\$3,500.00	\$3,500.00	\$5,350.00	\$5,350.00	\$7,061.00	\$14,122.00
29	P-101	REMOVAL OF FENCE	LF	150	\$20.00	\$3,000.00	\$13.00	\$1,950.00	\$14.00	\$2,100.00	\$43.00	\$6,450.00
30	P-101	PLUG 18" RCP	LS	1	\$750.00	\$750.00	\$2,000.00	\$2,000.00	\$4,600.00	\$4,600.00	\$3,468.00	\$3,468.00
31	P-101	CUT AND PLUG 12" SANITARY FORCE MAIN	LS	1	\$20,000.00	\$20,000.00	\$2,000.00	\$2,000.00	\$10,600.00	\$10,600.00	\$16,400.00	\$16,400.00
32	P-152	UNCLASSIFIED EXCAVATION	CY	11,000	\$15.00	\$165,000.00	\$6.50	\$71,500.00	\$28.82	\$317,020.00	\$18.00	\$198,000.00
33	P-152	MUCK EXCAVATION	CY	500	\$25.00	\$12,500.00	\$30.00	\$15,000.00	\$35.40	\$17,700.00	\$94.00	\$47,000.00
34	P-154	SUBBASE COURSE	CY	1,700	\$75.00	\$127,500.00	\$124.00	\$210,800.00	\$128.30	\$218,110.00	\$142.00	\$241,400.00
35	P-154	SEPARATION GEOTEXTILE	SY	1,800	\$3.50	\$6,300.00	\$2.50	\$4,500.00	\$4.15	\$7,470.00	\$3.00	\$5,400.00
36	P-156	CEMENT	TN	80	\$500.00	\$40,000.00	\$500.00	\$40,000.00	\$1,000.00	\$80,000.00	\$641.00	\$51,280.00
37	P-209	CRUSHED AGGREGATE BASE COURSE	SY	7,000	\$35.00	\$245,000.00	\$22.00	\$154,000.00	\$26.63	\$186,410.00	\$27.00	\$189,000.00
38	P-401	ASPHALT SURFACE COURSE	LF	2,200	\$140.00	\$308,000.00	\$169.00	\$371,800.00	\$186.53	\$410,366.00	\$271.00	\$596,200.00
39	P-406	CRACK REDUCTION MEMBRANE	LF	100	\$10.00	\$1,000.00	\$28.00	\$2,800.00	\$16.00	\$1,600.00	\$22.00	\$2,200.00
40	M-103	LIGHTED PORTABLE CLOSED RUNWAY MARKERS	EA	2	\$10,000.00	\$20,000.00	\$2,500.00	\$5,000.00	\$10,500.00	\$21,000.00	\$1,090.00	\$2,180.00
41	M-103	CLOSED TAXIWAY MARKERS (CONTRACTOR FURNISHED)	EA	2	\$2,500.00	\$5,000.00	\$1,200.00	\$2,400.00	\$2,600.00	\$5,200.00	\$805.00	\$1,610.00
42	M-107	AVIATION BARRICADES (CONTRACTOR FURNISHED)	LF	850	\$50.00	\$42,500.00	\$31.00	\$26,350.00	\$48.00	\$40,800.00	\$6.00	\$5,100.00
43	P-603	EMULSIFIED ASPHALT TACK COAT	GL	800	\$4.00	\$3,200.00	\$4.00	\$3,200.00	\$3.23	\$2,584.00	\$13.00	\$10,400.00
44	P-620	MARKING (INITIAL YELLOW)	SF	1,750	\$2.50	\$4,375.00	\$10.00	\$17,500.00	\$9.30	\$16,275.00	\$4.00	\$7,000.00
45	P-620	MARKING (PERMANENT YELLOW)	SF	1,750	\$2.50	\$4,375.00	\$4.00	\$7,000.00	\$3.50	\$6,125.00	\$4.00	\$7,000.00
46	P-620	MARKING (PERMANENT BLACK)	SF	3,400	\$2.50	\$8,500.00	\$2.00	\$6,800.00	\$1.82	\$6,188.00	\$4.00	\$13,600.00
47	P-620	REFLECTIVE MEDIA	LS	1	\$1,000.00	\$1,000.00	\$2,000.00	\$2,000.00	\$4,000.00	\$4,000.00	\$15.00	\$15.00
48	F-162	8' GALVANIZED CHAIN-LINK FENCE	LF	225	\$65.00	\$14,625.00	\$110.00	\$24,750.00	\$62.00	\$13,950.00	\$72.00	\$16,200.00
49	D-701	15" HDPE PIPE	LF	300	\$75.00	\$22,500.00	\$85.00	\$25,500.00	\$100.00	\$30,000.00	\$118.00	\$35,400.00
50	D-701	18" HDPE PIPE	LF	630	\$90.00	\$56,700.00	\$94.00	\$59,220.00	\$107.00	\$67,410.00	\$135.00	\$85,050.00
51	D-701	24" HDPE PIPE	LF	240	\$105.00	\$25,200.00	\$117.00	\$28,080.00	\$143.20	\$34,368.00	\$149.00	\$35,760.00
52	D-701	24" RCP CLASS V	LF	450	\$130.00	\$58,500.00	\$70.00	\$31,500.00	\$143.00	\$64,350.00	\$144.00	\$64,800.00
53	D-701	24" RCP CLASS V	LF	175	\$148.00	\$25,900.00	\$94.00	\$16,450.00	\$200.00	\$35,000.00	\$189.00	\$33,075.00
54	D-705	6" PVC UNDERDRAIN OR EDGE DRAIN PIPE (PERFORATED)	LF	3,100	\$45.00	\$139,500.00	\$31.00	\$96,100.00	\$53.64	\$166,284.00	\$72.00	\$223,200.00
55	D-705	6" PVC UNDERDRAIN OR EDGE DRAIN PIPE (SOLID)	LF	650	\$25.00	\$16,250.00	\$34.00	\$22,100.00	\$34.20	\$22,230.00	\$73.00	\$47,450.00

BID TABULATION

Construct Taxiway B - Bid Package 1

Delaware Coastal Airport
Georgetown, Delaware

AIP Project No. 3-10-0007-040-2023 (Design)
AIP Project No. 3-10-0007-Pending (Construction)
Delta Project No. 22033

Bid Opening Date: May 1, 2024

Item No.	Spec. No.	Description	Unit	Bid Quantity	Engineer's Estimate		Allan Myers MD, Inc.		George & Lynch, Inc.		Atlantic Contracting & Material Co., Inc.	
					Unit Price	Estimate Amount	Unit Price	Bid Amount	Unit Price	Bid Amount	Unit Price	Bid Amount
56	D-705	HEAVY DUTY UNDERDRAIN OR EDGE DRAIN CLEANOUT	EA	23	\$1,500.00	\$34,500.00	\$1,400.00	\$32,200.00	\$3,025.00	\$69,575.00	\$2,370.00	\$54,510.00
57	D-751	DRAINAGE INLETS	EA	5	\$6,000.00	\$30,000.00	\$3,500.00	\$17,500.00	\$6,000.00	\$30,000.00	\$12,100.00	\$60,500.00
58	D-751	DRAINAGE INLETS, AIRCRAFT RATED	EA	2	\$10,000.00	\$20,000.00	\$6,200.00	\$12,400.00	\$10,000.00	\$20,000.00	\$15,800.00	\$31,600.00
59	D-751	RISER STRUCTURE	EA	1	\$8,000.00	\$8,000.00	\$30,000.00	\$30,000.00	\$13,000.00	\$13,000.00	\$19,100.00	\$19,100.00
60	D-752	6" UNDERDRAIN ENDWALL	EA	1	\$600.00	\$600.00	\$600.00	\$600.00	\$1,125.00	\$1,125.00	\$1,600.00	\$1,600.00
61	D-752	FES, 18" RCP	EA	1	\$800.00	\$800.00	\$1,100.00	\$1,100.00	\$1,450.00	\$1,450.00	\$3,400.00	\$3,400.00
62	D-752	FES, 18" HDPE	EA	1	\$700.00	\$700.00	\$1,100.00	\$1,100.00	\$1,355.00	\$1,355.00	\$3,400.00	\$3,400.00
63	D-752	FES, 24" HDPE	EA	1	\$850.00	\$850.00	\$1,500.00	\$1,500.00	\$1,505.00	\$1,505.00	\$3,500.00	\$3,500.00
64	T-901	SEEDING	AC	13	\$5,500.00	\$71,500.00	\$2,500.00	\$32,500.00	\$5,462.00	\$71,006.00	\$4,300.00	\$55,900.00
65	T-908	MULCHING	AC	13	\$1,000.00	\$13,000.00	\$1,800.00	\$23,400.00	\$3,371.00	\$43,823.00	\$4,300.00	\$55,900.00
66	L-107	L-807 I-B SIZE 2 WIND CONE AND FOUNDATION, IN PLACE	EA	1	\$20,000.00	\$20,000.00	\$40,000.00	\$40,000.00	\$25,000.00	\$25,000.00	\$31,100.00	\$31,100.00
67	L-107	SEGMENTED CIRCLE MARKER SYSTEM, IN PLACE	LS	1	\$15,000.00	\$15,000.00	\$40,000.00	\$40,000.00	\$25,000.00	\$25,000.00	\$28,300.00	\$28,300.00
68	L-108	NO. 8 AWG, 5KV, L-824 TYPE C CABLE, INSTALLED IN TRENCH, DUCT BANK OR CONDUIT	LF	8,200	\$2.50	\$20,500.00	\$3.50	\$28,700.00	\$3.45	\$28,290.00	\$5.00	\$41,000.00
69	L-108	NO. 6 AWG, 600V, L-824 RHW CABLE, INSTALLED IN TRENCH, DUCT BANK OR CONDUIT	LF	2,300	\$5.00	\$11,500.00	\$4.40	\$10,120.00	\$4.28	\$9,844.00	\$6.00	\$13,800.00
70	L-108	NO. 6 AWG SOLID BARE COPPER COUNTERPOISE WIRE, INSTALLED ABOVE THE DUCT BANK OR CONDUIT, INCLUDING CONNECTIONS/TERMINATIONS	LF	5,400	\$3.00	\$16,200.00	\$2.60	\$14,040.00	\$2.51	\$13,554.00	\$4.00	\$21,600.00
71	L-110	CONCRETE ENCASED ELECTRICAL DUCT BANK, 2 WAY - 2" PVC CONDUIT	LF	250	\$60.00	\$15,000.00	\$93.00	\$23,250.00	\$91.00	\$22,750.00	\$121.00	\$30,250.00
72	L-110	NON-ENCASED ELECTRICAL CONDUIT, 1 WAY - 2" PVC CONDUIT	LF	4,300	\$7.00	\$30,100.00	\$14.00	\$60,200.00	\$13.91	\$59,813.00	\$19.00	\$81,700.00
73	L-110	NON-ENCASED ELECTRICAL CONDUIT, 2 WAY - 2" PVC CONDUIT	LF	850	\$10.00	\$8,500.00	\$22.00	\$18,700.00	\$21.40	\$18,190.00	\$29.00	\$24,650.00
74	L-115	ELECTRICAL JUNCTION STRUCTURE, 2-UNIT L-867 PULLCAN PLAZA	EA	8	\$5,000.00	\$40,000.00	\$9,000.00	\$72,000.00	\$8,560.00	\$68,480.00	\$11,300.00	\$90,400.00
75	L-125	L-858(L) AIRFIELD GUIDANCE SIGN (3-4 CHAR.) ON NEW FOUNDATION	EA	8	\$10,000.00	\$80,000.00	\$12,000.00	\$96,000.00	\$11,770.00	\$94,160.00	\$15,600.00	\$124,800.00
76	L-125	AIRFIELD GUIDANCE SIGN PANEL REPLACEMENT	EA	2	\$2,000.00	\$4,000.00	\$5,000.00	\$10,000.00	\$4,280.00	\$8,560.00	\$5,700.00	\$11,400.00
77	L-125	L-861(TL) BASE MOUNTED MITL (LED)	EA	32	\$2,000.00	\$64,000.00	\$2,600.00	\$83,200.00	\$2,568.00	\$82,176.00	\$3,400.00	\$108,800.00
78	L-125	GROUND RODS	EA	400	\$400.00	\$160,000.00	\$135.00	\$54,000.00	\$134.00	\$53,600.00	\$177.00	\$70,800.00
79	R-707	RIPRAP (CLASS)(TYPE)	SY	1,150	\$85.00	\$97,750.00	\$50.00	\$57,500.00	\$95.00	\$109,250.00	\$105.00	\$120,750.00
80	R-808	SOIL STABILIZATION MAT (CHANNEL)	SY	1,500	\$4.00	\$6,000.00	\$2.50	\$3,750.00	\$3.31	\$4,965.00	\$5.00	\$7,500.00
81	R-808	SOIL STABILIZATION MAT (SLOPE)	SY	2,950	\$3.80	\$11,210.00	\$2.50	\$7,375.00	\$4.44	\$13,098.00	\$6.00	\$17,700.00
82	R-808	TURF REINFORCEMENT MATTING	SY	400	\$7.50	\$3,000.00	\$5.00	\$2,000.00	\$4.50	\$1,800.00	\$6.00	\$2,400.00
83	SP-41	WIND TEE REMOVAL, REFURBISHMENT, AND RELOCATION	LS	1	\$50,000.00	\$50,000.00	\$200,000.00	\$200,000.00	\$26,750.00	\$26,750.00	\$36,000.00	\$36,000.00
84	SP-42	TEMPORARY SECURITY FENCE	LS	1	\$5,000.00	\$5,000.00	\$100,000.00	\$100,000.00	\$37,000.00	\$37,000.00	\$17,200.00	\$17,200.00
Total:						\$3,041,260.00		\$3,375,555.00		\$3,825,462.00		\$4,077,074.00 *
DBE Participation:						Goal = 12.48%		12.50%		12.54%		5.40% *

* Denotes Extension Error

THIS IS TO CERTIFY THAT THE BIDS TABULATED HEREIN WERE OPENED AT 11:00 AM LOCAL TIME ON MAY 1, 2024 AT THE COUNTY COUNCIL CHAMBERS, SUSSEX COUNTY ADMINISTRATIVE BUILDING, 1ST FLOOR, 2 THE CIRCLE, GEORGETOWN, DELAWARE 19947, AND THAT ALL OF SAID BIDS WERE ACCOMPANIED BY ACCEPTABLE BID BONDS OR CERTIFIED CHECKS.

SIGNATURE OF ENGINEER:  DATE: 5/3/2024

TASK ORDER NO. FIVE (5)
PROFESSIONAL SERVICES AGREEMENT



PROJECT: Construct Parallel Taxiway B - Phase 1 (CA)

AIRPORT: Delaware Coastal Airport

DELTA PROJECT NO.: 22033

DATE OF ISSUANCE: April 30, 2024

ATTACHMENTS: 1) Scope of Services
2) Rate Schedule

METHOD OF PAYMENT: Construction Administration - Unit Price + Fixed Fee

TASK ORDER AMOUNT: \$480,000

CONTRACT TIME: 200 Calendar Days Estimated Construction Contract Time

PROJECT DESCRIPTION: • Construction Administration Services

The original Agreement for Professional Services between Sussex County, Delaware (OWNER) and Delta Airport Consultants, Inc. (CONSULTANT) for Professional Services at Delaware Coastal Airport dated April 23, 2020, shall govern all TASK ORDERS executed under this Agreement unless modified in writing and agreed to by CONSULTANT and OWNER.

At the OWNER's request, and with an associated reduction in the CONSULTANT's fixed fee, the OWNER has agreed to assume a portion of the CONSULTANT's liability and business risk associated with subcontracted services provided under this Agreement. The OWNER agrees to indemnify and hold harmless the CONSULTANT against all costs arising out of or in connection with the failure of any Subconsultant to provide its services in accordance with the terms of its subcontracts. The OWNER shall be entitled to any payments received by CONSULTANT from its Subconsultants for settlement of any claims related to the Project. The OWNER assumes no liability for direct payment to the Subconsultants and CONSULTANT agrees to indemnify and hold the OWNER harmless from any and all claims by any Subconsultant which arises out of any failure of CONSULTANT to make payments to the Subconsultant provided that the OWNER has already paid CONSULTANT all amounts owed under this Agreement.

ACCEPTED:

Digitally signed by Kenneth
W Moody
Date: 2024.05.08 14:47:02
-04'00'

Kenneth W. Moody, PE
Vice President
Delta Airport Consultants, Inc.
3544 North Progress Avenue, Suite 200
Harrisburg, PA 17110

APPROVED:

by: _____

Sussex County, Delaware
2 The Circle, P.O. Box 589
Georgetown, DE 19947



Construct Parallel Taxiway B - Phase 1 (CA)
Delaware Coastal Airport
Delta Project No. 22033

April 30, 2024

PHASE	DETAILED TASKS
CONSTRUCTION ADMINISTRATION (CA)	Owner Coordination Release for Construction Drawings & Specs Coordinate Subconsultants Project Correspondence Preconstruction Meeting Shop Drawing Review Construction Administration Materials Testing Review Site Visits Punchlist Inspection Final Inspection Record Drawings Airport Layout Plan Update Reimbursement Requests

ITEMS NOT INCLUDED IN SCOPE:

- Field Representative Services
- Bidding

**ATTACHMENT 2
RATE SCHEDULE**



Delta Airport Consultants, Inc.

Date: January 4, 2024

Item	2024
Work Hours Billing Rates (with overhead)	
Principal	\$280.00
Project Manager/Registered Professional	\$257.00
Design Professional (Engineer/Planner)	\$170.00
Project Production/Administration	\$133.00
Field Representative (RPR)	\$135.00
Direct Nonsalary Expenses	
Automobile (per mile)	Federal Gov. guidelines
Aircraft (per mile)	Federal Gov. guidelines
Per Diem - Field Assignments	Federal Gov. guidelines
Meals & Lodging per calendar day (long term)	
Airline, Rental Car, Charter, etc.	Direct
Printing	Direct
Bid Advertisement	Direct
Meals & Lodging (short term)	Direct
Miscellaneous	Direct

Notes:

1. Billing rates for future years will be increased by 5% annually.
2. Billing rates based on 2024 salaries.
3. Work hour rates include labor overhead, general & administrative overhead per FAA AC 150/5100-14E, paragraph 4-10.

ENGINEERING DEPARTMENT

MIKE HARMER, P.E.
SUSSEX COUNTY ENGINEER

(302) 855-7370 T

(302) 854-5391 F

mike.harmer@sussexcountype.gov



Sussex County

DELAWARE
sussexcountype.gov

Memorandum

TO: Sussex County Council
The Honorable Michael H. Vincent, President
The Honorable John L. Rieley, Vice President
The Honorable Cynthia C. Green
The Honorable Douglas B. Hudson
The Honorable Mark G. Schaeffer

FROM: Hans Medlarz, P.E., County Engineer, ret.

RE: ***Inland Bays Loop Project, S24-01***
A. Approval of DP&L License Agreement

DATE: October 29, 2024

The 5-year capital plan approved in the County's FY 24 Capital Budget anticipated several large projects at the Inland Bays Regional Wastewater Facility (IBRWF). Ultimately, treated effluent from the IBRWF will be distributed to agricultural partners and forested spray sites under the recently issued DNREC permit no. 359141-08, as well as a rapid infiltration basin under DNREC permit review to be permitted, constructed and maintained by Artesian Wastewater Resources on leased County property.

The Inland Bays Loop Project, S24-01, included over 7 miles of mostly 18" – 24" diameter ductile iron pipeline with concrete meter vaults at twelve (12) locations where effluent disposal is planned. The majority of the work occurs on Sussex County owned lands, with some portions of the pipeline crossing or running with DelDOT right-of-way, including the Mount Joy Road segment applicable to the DelDOT Utility Agreement approved by Council on February 20, 2024.

The Loop Project was publicly advertised, and twelve (12) contractors attended a pre-bid meeting on February 21, 2024. On March 14, 2024, seven (7) bids were received, with Atlantic Contracting & Material Co., Inc. submitting the lowest base bid. Several alternate bids for addition or deduction of pricing were included in the Bid Form to evaluate pipeline material options, including Alternate Bid 9A, which stipulated use of domestic pipe fittings. The Engineering Department reviewed all bid pricing and considered Base Bid with Alternate Bid 9A, in the amount of \$7,649,916.00, as serving the best project interests of Sussex County.



On April 9, 2024, County Council awarded the Loop Project, S24-01, to Atlantic Contracting & Material Co., Inc., (ACM) in the amount of \$7,649,916.00 with funding provided through the ARPA.

The Loop Project was the initial step towards constructing a treated effluent distribution system at IBRWF. Design and permitting efforts continued for anticipated projects including the forested spray-field header piping; forested spray-field diffuser piping; treated effluent storage; and electrical powering and communication control of the actuated control valves via integration to SCADA.

The Engineering Department completed supplemental construction drawings for the forested spray-field header piping in cooperation with ACM. They presented Change Order No. 1, for construction of the forested spray-field header piping, using current unit pricing and new not to exceed costs related only to additional survey, tree clearing done directly by ACM, and labor associated with the atypical pipe assemblies where future distribution & diffuser piping will connect to the spray-field header. Council approved the associated Change Order No.1 in the amount of \$2,179,674.00 on October 15, 2024.

A DP&L electrical transmission right-of-way with three (3) separate overhead circuits exists on County property at the IBRWF. The Loop Project included three (3) pipeline crossing locations of said DP&L easement. Coordination of the Loop Project with DP&L resulted in the shift of the pipeline alignment further away from existing utility poles. ACM developed costs for additional tree clearing and field survey related to alignment revisions under Change Order No. 2. in the amount of \$136,460.00 which was also approved by Council on October 15, 2024.

Since then, we received the DP&L License Agreement and Exhibits A, B and C relative to the construction and occupation of the loop piping within the confines of the DP&L transmission line easement. Pursuant to the Standard Property Use Requirements, DP&L typically charges an application fee, a commercial License Agreement fee plus land value. However, as a courtesy to the County DP&L is waiving the application fee and the land value fee and only requires payment of the License Agreement fee of \$2,500.00. In addition, the County will have to supply an insurance certificate which includes DP&L as additional insured as well as a waiver of subrogation. In summary, the Engineering Department requests Council's approval of the License Agreement, issuance of the required special insurance certificate and payment of the fee in the amount of \$2,500.00.

License Agreement

This License Agreement (the “License”), made this _____ day of _____, 2024, by and between DELMARVA POWER & LIGHT COMPANY (“Delmarva” or “Licensor”), a State of Delaware and Commonwealth of Virginia Corporation, whose address is 2530 North Salisbury Blvd., Salisbury, Maryland 21801 and SUSSEX COUNTY, a political subdivision of the State of Delaware, whose address is 2 The Circle, PO Box 589, Georgetown, Delaware, 19947 (“Licensee”).

WHEREAS, Licensee desires to obtain a license agreement to license approximately 0.25 acres or 11,000 square feet of Delmarva’s Utility Easement in three (3) separate locations for the sole purpose of installing Ductile Iron Pipe (DIP) for transmission of treated effluent water, with the said property being identified as Tax Parcel No. 234-22.00-10.00 and recorded in the Sussex County Recorder of Deeds Office at Book 3026, Page 158, and further shown and attached hereto as Exhibits “A, B and C” and made a part hereof to be known as the (“Licensed Area”).

WHEREAS, Delmarva desires to license such area (“Licensed Area”) to Licensee pursuant to the terms, conditions, and covenants of this License Agreement;

NOW, THEREFORE, in consideration of the foregoing and of the conditions and covenants hereinafter set forth, Delmarva grants this license on behalf of and for itself, its successors and assigns, under and subject to the following terms, covenants, and conditions hereinafter recited, which are hereby accepted and agreed to, by Licensee:

1. Licensee’s use of Delmarva’s property is solely limited to installation of Ductile Iron Pipe (DIP) for transmission of treated effluent water (“Use”) in the 0.25 acres or 11,000 square feet that are identified and highlighted on Exhibits “A, B and C” which is attached hereto and made a part hereof (“Licensed Area”).
2. This License is effective for the term of 20 years, commencing on the date hereof and ending on _____, 2044. At the expiration of the initial license period, this agreement may be renewed as mutually agreeable between the Licensor and Licensee.
3. Licensee shall execute this License Agreement prior to Delmarva’s execution and shall submit the following payment to Delmarva with the executed License Agreement for Delmarva’s execution: a one-time fee in the amount of Two Thousand Five Hundred and 00/100 Dollars (\$2,500.00).
4. Delmarva reserves the perpetual right to construct and maintain in, over, under, along, through and across the above-described License Area such overhead and/or underground electric transmission and/or distribution cables, fiber optic cables, pipes, conduits, and/or wires and appurtenant facilities (including ground, neutral or static wires and/or cables) and such electric equipment, telecommunication equipment or gas pipelines, oil pipelines and appurtenant facilities as it, or they, may, from time to time, deem necessary or advisable. Additionally, Delmarva

reserves the right to enter for any and all environmental studies and testing, without limitations.

5. Licensee accepts the License Area in the condition as it exists on the date hereof. Delmarva makes no representation or warranty, express or implied, with respect to the suitability of the License Area for the Use or the quality and condition of its soils.
 6. Licensee shall neither cut trees nor sell or remove sand, gravel, topsoil, sod, or minerals.
 7. Licensee shall not break up or redirect any established watercourses or ditches.
 8. Licensee shall not hunt, or allow hunting of any kind, on any portion of said property.
 9. Licensee shall forward all correspondence and any required notices to:
Delmarva Power & Light Company
Real Estate Department
Mailstop 29SC55
P.O. Box 1739
Salisbury MD 21802-1739
- Delmarva shall forward all correspondence and any required notices to:
Sussex County, a Political Subdivision
2 The Circle
PO Box 589
Georgetown, DE 19947
10. Delmarva shall have continuous unobstructed access to the License Area.
 11. No other uses of the License Area will be permitted unless prior written permission is obtained from Delmarva. Licensee also acknowledges that it has no right to assign, delegate or transfer the license granted herein to any person or entity without the prior written consent of Delmarva.
 12. Extreme care must be used in the location and operation of all persons and equipment to ensure that such persons and equipment will at no time come within 20 feet of any electric circuits attached to steel structures or within 10 feet of any other electric circuits. Also, all activities must be performed in strict compliance with the National Electric Safety Code (NESC) and all other applicable codes, laws and regulations, including but not limited to the Overhead High-Voltage Line Safety Act, 16 Del. C. Pt. VI, Ch. 74B et seq.

13. In connection with or as a result of the requested Use, Delmarva shall be put to no cost or expense.
14. Licensee shall be responsible for any damages to Delmarva's property or facilities arising directly or indirectly from the Use of the License Area and shall promptly reimburse Delmarva for the cost of repairing any such damages.
15. Licensee shall restore the surface of the License Area to its existing condition after initial construction of its Use and whenever repairs or maintenance of said Use require the surface to be altered, and if Licensee should fail to do so in a reasonably timely manner, then Delmarva may do so, and Licensee agrees to pay Delmarva on demand the costs and expense thereof. Any debris left on Delmarva's property as a result of the Use must be removed by Licensee.
16. Delmarva shall not be responsible or liable for any damage or injury (including death resulting therefrom) to any persons and/or property including but not limited to any of Licensee's servants, employees, agents, visitors, or licensees, occurring on or about the License Area or Delmarva's property, resulting or arising from any cause or occurrence relating to Licensee's Use or occupancy of the License Area.
17. Licensee shall indemnify and hold harmless Delmarva, its parents, and their subsidiaries (which shall be deemed to include their directors, officers, employees, agents and servants) against any and all losses, expenses, demands, claims and liability in connection with injuries and property damage to persons, firms or corporations (including the parties hereto and their respective employees, agents and servants, licensees and invites, trespassers and/or the general public's use of the subject License Area) caused by or growing out of Licensee's presence on, or Use of, the License Area. Licensee agrees to defend at his expense, including attorney's fees, any suit or action brought against Licensee and/or Delmarva, its parents, and their subsidiaries, based on any alleged injuries or damages, losses and expenses caused by or growing out of Licensee's presence on, or Use of, the License Area.
18. At no time shall Licensee store vehicles, fuel or explosives on the License area.
19. Licensee shall comply with all applicable federal, state and local laws, codes and regulations pertaining to the Use, and must obtain all necessary permits and/or approvals needed, including but not limited to any building permits, at the Licensee's expense.
20. Licensee shall conduct all activities on the License Area in compliance with all applicable laws, including environmental laws.
21. Licensee and its contractors, who conduct any operations or perform any work permitted by this agreement or any activity connected therewith, shall procure and

maintain at its own expense the following minimum insurance in forms and with insurance companies rated at least A-VII by AM Best:

- (a) Commercial General Liability and/or Umbrella/Excess Liability (including contractual liability coverage equivalent to what is insured by ISO CGL form 00 01): \$2,000,000 per occurrence and in the aggregate;
 - (b) Workers Compensation insurance for statutory obligations imposed by Workers Compensation, Occupational Disease, or other similar laws;
 - (c) Employer's Liability: \$1,000,000 per accident/ per disease, per employee/per disease, policy limits
 - (d) Business Automobile Liability (for all owned, non-owned, hired, and leased vehicles): \$2,000,000 per accident.
 - (e) Licensee shall provide certificates of insurance and applicable policy wording and/or endorsements to Delmarva Power & Light Company, Attention: Manager, Real Estate, 2530 N Salisbury Boulevard Salisbury, MD, 21801, Mail stop 29SC55.
 - (f) With respect to subsections (a) and (d) above, such insurance shall include Delmarva Power & Light Company, its officers, directors, employees and agents as additional insured. All insurance required hereunder shall provide a waiver of subrogation in favor of Delmarva Power & Light Company, state that required coverage is primary to any other valid insurance available to Delmarva Power & Light Company (to the extent permitted by applicable insurance law) and allow cross-liabilities and coverage regardless of fault. Licensee shall provide at least thirty (30) days prior written notice to Delmarva Power & Light Company of cancellation of any required coverage if not replaced.
 - (h) In the event any Subcontractor(s) provide any services hereunder, Licensee shall require such Subcontractor(s) to maintain insurance in accordance with this Section.
22. Failure by either party to this License Agreement to enforce its rights under this Agreement does not constitute a waiver of those rights.
23. All rights and duties under this License Agreement benefit and bind Delmarva and Licensee and their successors and assigns.

IN WITNESS WHEREOF, these presents have been duly executed and delivered.

Witness:

Licensor:

DELMARVA POWER & LIGHT COMPANY

By: _____

Name: _____

Title: _____

Witness:

Licensee :

SUSSEX COUNTY, a Political Subdivision

By: _____

Name: _____

Title: _____

ENGINEERING DEPARTMENT

MIKE HARMER, P.E.
SUSSEX COUNTY ENGINEER

(302) 855-7370 T
(302) 854-5391 F
mike.harmer@sussexcountype.gov



Sussex County

DELAWARE
sussexcountype.gov

Memorandum

TO: Sussex County Council
The Honorable Michael H. Vincent, President
The Honorable John L. Rieley, Vice President
The Honorable Cynthia C. Green
The Honorable Douglas B. Hudson
The Honorable Mark G. Schaeffer

FROM: Hans Medlarz, P.E., County Engineer, ret.

RE: *South Coastal WRF Treatment Process Upgrade No.3 & Rehoboth Beach WTP Capital Improvement Program, Phase 2*
A. Electrical Construction, Project C19-17, Change Order No. 28

DATE: October 29, 2024

The South Coastal WRF Treatment Process Upgrade No.3 was designed and bid in conjunction with the Rehoboth Beach WTP Capital Improvement Program, Phase 2. The latter has been completed and only the South Coastal component is still ongoing. It encompasses the following components and statuses:

- a. Effluent Forcemain Relocation/Replacement; Completed in fall of 2019.
- b. Influent Forcemain Consolidation; Completed in May of 2020.
- c. Drainage Network Rerouting;

This scope was not included in the base bid. After cost comparison between the General Labor & Equipment Contract versus a change order under Ronca's general construction contract; Council awarded the stand alone Change Order Request 554-001 to Ronca & Sons, Inc. in the amount of \$104,592.96 on March 10, 2020. The construction was completed in July 2020.

- d. General Construction Project C19-11; awarded on December 17, 2019, to M.F. Ronca & Sons, Inc.



On March 10, 2020, Council authorized Change Order No.1 in the net amount of \$97,294.31 for deletion of the record drawing requirement and the modification of the RBWTF influent forcemains.

On May 12, 2020, Council authorized credit Change Order No. 2 in the amount of (\$12,705.00) eliminating an explosion proof motor requirement.

On July 28, 2020, Council approved credit Change Order No. 3 in the combined amount (\$9,764.30) for use of County surplus materials.

Change Order No.4 in the amount of \$871,000.00 for the repairs of partial failures at the two City of Rehoboth's wastewater treatment plant oxidation ditch systems was also approved on July 28, 2020. M.F. Ronca & Sons, Inc. completed the scope in May of 2021 and the County increased the flow contribution to the City's plant.

On December 15, 2020, County Council approved Change Order No. 6 for steel framing repairs in the first oxidation ditch on a time & material basis up to \$10,500.00 in addition to the concrete repairs conducted per the awarded contingent unit price schedules.

The County initiated RFP-019 for interior headworks piping modifications and RFP-023 covering the addition of a cross connection between the existing 14-inch process drain header for Aeration Tank Nos. 1-4 and the new header for the Aeration Tank Nos. 5-8. On September 22, 2020, Council approved Change Order No.5 in the combined amount of \$32,991.66.

GHD issued RFP-031 for the installation of plug valves on each of the 12-inch recycle influent pipes to be connected to the existing Aeration Tank Nos. 1-4 and to the new Aeration Tank Nos. 7-8. On December 15, 2020, Change Order No. 7 was approved for said shut off valves in the amount of \$31,974.51.

The new South Coastal aeration basin had to be connected to the existing large diameter sludge return piping requiring a forward flow stoppage. Minimizing the joint risk M. F. Ronca proposed a line stop approach under Change Order No. 8. Since it also gained construction efficiency, they offered to only charge for the subcontractor work.

In the spring of 2021, the Rehoboth Beach WTP oxidation ditch rehabilitation was receiving expansive attention including:

- Contingent Unit Price Concrete Repairs, Bid Items F-19 & F-20
- Steel Repairs authorized under Change Order No. 6
- Steel Coatings authorized as part of Change Order No. 4

In addition, all of the leaking expansion joints have been repaired under a time & material approach. On March 9, 2021, County Council approved Change Order Nos. 8 and 9 in the respective amounts of \$34,765.50 and \$45,600.00.

Only one of the two headworks vertical influent pipes has a shut off valve and Environmental Services requested a second valve. In addition, two of the existing headworks slide gates were

compromised in need of replacement. On May 25, 2021, Council approved Change Order No. 10 in the aggregate amount of \$34,160.64.

The County initiated RFP-039 addressing modifications to two slide gates avoiding conflict with the new air piping. In addition, it was discovered during the rehabilitation work in the grit tanks, that the existing influent chutes to the stacked tray grit removal systems were significantly compromised. On June 22, 2021, Council approved Change Order No. 11 in the aggregate amount of \$59,557.16.

The design team-initiated RFP-038 for exhaust duct modifications associated with the new turbo blowers and RFP-041 correcting the elevation difference in the headworks cross channel. On July 13, 2021, Council approved Change Order No. 12 to M.F. Ronca & Sons in the aggregate amount of \$14,700.07.

The contract as bid included concrete repairs to the City's headworks and influent splitter box. With the structures by-passed and accessible, the full extent of the damage required an alternative approach detailed in RFP-037 including full demolition of the upper level as well as the channel between it and the splitter box. GHD, the City Engineer and the County Engineer supported the approach, and the change order was within budget of the City's financing arrangements previously approved by the City and County elected officials. Therefore, Council approved Change Order No. 13 to M.F. Ronca & Sons in the amount of \$1,043,243.92 on August 10, 2021.

The City requested M.F. Ronca & Sons' assistance in the wetwell cleaning of the State Rd. pump station to allow a full evaluation in preparation of the upgrade design. In addition, the City requested to modify the air intake for B-10 Building ventilation from a roof mount to an existing window opening. On November 30, 2022, County Council approved Change Order No. 14 in the aggregate amount of \$7,380.37.

Upon exposure of the normally submerged piping at the oxidation ditches, GHD formulated an initial repair scope for the influent, return sludge & air piping including replacement of valves and fittings. It was subsequently reduced and Michael F. Ronca & Sons, Inc. proposed to perform the modified repair scope for \$324,996.81. GHD, the City Engineer and the County Engineer supported the modified approach. However, this amount is not within budget of the City's financing arrangements previously approved. The City will pay for this change order directly out of City funds. County Council approved Change Order No. 15 on January 11, 2022, subject to direct payment by the City. Since then, it was determined that the pipe support configuration for the replacement of oxidation ditch influent piping at the City's WTP required additional supports and RFP-056 was issued. Michael F. Ronca & Sons, Inc. proposed to perform the expanded repair scope for \$8,992.49. County Council approved Change Order No. 17 to M.F. Ronca & Sons in the amount of \$8,992.49 on January 25, 2022.

GHD's design scope included a separate task for the hydraulic transient analysis of the South Coastal effluent force under various pumping scenarios.

After County approval of the findings, GHD issued RFP-052 for replacing air valves on the effluent force main and installing additional air valves at new locations. This work scope was not known at time of base bid and hence not included. On January 11, 2022, County Council issued Change Order No. 16 to M.F. Ronca & Sons in the amount of \$88,132.23.

The South Coastal RWF's return sludge pumping station has three (3) pumps, two of which have been upgraded. The third unit recently experienced a failure, and the Environmental Services requested replacement of the pump and piping to be integrated in the project as per RFP-053. Michael F. Ronca & Sons, Inc. proposed Change Order No. 18 in the amount of \$31,101.61, which Council approved on January 25, 2022.

Under RFP-053 the Environmental Services staff requested replacement of two (2) compromised pumps and rail systems in the existing filtrate return pump station in the filter building. Under RFP-057 the City staff requested new fiberglass baffles and a guide bracket assembly to replace the original wooden baffle assembly located in the flow splitter box. M.F. Ronca & Sons proposed to complete the work for \$90,081.84 and \$8,132.66 respectively which Council approved on February 8, 2022, via Change Order 19.

The City requested M.F. Ronca & Sons' assistance in the installation of a lintel above the screen chute complete with control joints limiting vertical cracking. Ronca proposed to complete this work for \$7,426.59.

Starting in 2021, Environmental Services started experiencing more frequent malfunctions and alarm call outs with the influent screens at the Inland Bays RWF. In addition, a reduction in screen bar opening from ¼-inch to 3/16-inch opening will help the facilities sludge accumulation. The units were commissioned in the fall of 2010 and normally have a 15-year service life. The Engineering Department requested the assistance of Michael F. Ronca & Sons, Inc. and their investigation revealed that a full replacement could be accomplished for \$253,417.58, which was only 10% more expensive than a full rebuilt. Therefore, County Council approved Change Order No. 20 in the aggregate amount of \$260,844.17 on March 8, 2022 for the replacement in kind of two screens at Inland Bays and the masonry work at the City's plant.

The South Coastal facility requires alkalinity adjustments. In the past caustic soda was used however with the upgrade project the approach was switched to magnesium hydroxide. The as bid design included an innovative low energy consumption type Enviromix gas mixing system with a performance guarantee which was not met at start up. Therefore, the design approach was switched to a traditional impeller type mixing system. Michael F. Ronca & Sons, priced the modification including the full contract credits relating to the original Enviromix system and on March 29, County Council approved Change Order No. 21 in the aggregate amount of \$45,989.72.

The FY2022 Environmental Services budget included roof repairs of the South Coastal administration building and conversion of an existing pole building to an electrical panel shop. M. F. Ronca & Sons already has subcontractors in their scope of work who perform this

type of work. They priced the building modification and selectively investigated the roof conditions. The roof dating to the original construction needs full replacement and has areas of compromised decking. Due to market volatility, long lead times and anticipated incremental increases in roofing material (membrane & tapered insulation) costs, pricing includes a material escalation allowance.

Upon delivery of roofing materials final costs will be incorporated in a corrective change order reflecting actual material increases. Roof decking replacement will be performed at a unit cost of \$25.00 per SF incorporated into the corrective change order. On May 10, 2022, Council approved Change Order No. 22 in the aggregate amount of \$306,692.52 for pole building enclosure and admin building roof replacement followed by a later corrective change order adjusting unit costs and material pricing.

Environmental Services initiated RFP-067 for painting of the original 1970s mechanical building pump room and M. F. Ronca & Sons proposed to perform the work for \$7,893.90. On June 7, 2022, Council approved Change Order No. 23 in the amount of \$7,893.90.

Environmental Services initiated RFPs-072 & 073. The first deals with a new isolation valve on the existing 8-inch equalization return line in the Mechanical Building Pump Room. The second one modifies the PLC control logic in motor circuit protection of the new turbo blowers and the human machine interfaces graphic displays. On August 23, 2022, Council approved Change Order No. 24 to M.F. Ronca & Sons in the aggregate amount of \$12,829.83.

The headworks at the SCRWF are covered and the ventilated air treated for odors. The contract included unit pricing repair items for the headworks. The damage discovered during the rehabilitation work in the headworks and grit tanks indicated corrosion way above the anticipated levels. Therefore, the Engineering Department initiated RFP-071 for improvements to the headworks ventilation. After value engineering by M. F. Ronca & Sons they proposed to perform the work for \$126,590.76. On October 11, 2022, Council approved Change Order No. 25, significantly extending the asset life of the headworks in the amount of \$126,590.76.

Upon condition exploration of the City's main system pump station on State Street, GHD formulated an initial repair scope and subsequently issued RFP-075 for the repairs. This station also carries the County's Henlopen Acres Sewer District Area flows, and the County participates in the repair effort. With the urgency of the repair evident, the City requested inclusion in the project. M. F. Ronca & Sons, Inc. proposed to perform the modified repair scope for \$2,270,000.00. GHD, the City Engineer and the County Engineer supported the modified approach. On December 6, 2022, Council approved Change Order No. 26 to Michael F. Ronca & Sons, Inc. to perform the expanded State Street Pump Station repair scope for \$2,270,000.00. The City will pay for this change order directly out of City funds with separate invoice by contractor. In addition, with concurrence of the City, County Council granted Substantial Project Completion for the Rehoboth Beach WTP Capital Improvement Program, Phase 2 as of November 14, 2022.

In January of 2023, GHD conducted a factory acceptance test of the new turbo blower system controls. The test revealed that modifications to the PLC and HMI programs were necessary. All parties agreed that the quantity of the desired modifications would trigger RFP-079. M. F. Ronca & Sons, Inc. proposed to perform the additional scope for \$4,412.55.

The original bid contained a unit cost for grit removal from the sludge holding lagoons. For Lagoon B a hydraulic removal was considered but due to the quantity of grit a mechanical removal was analyzed. It would result in the destruction of the 20-years+ old liner. However, despite the replacement cost of the liner in the amount of \$84,375.17 the overall approach proved to be more cost effective and resulted in a new liner. On March 21, 2023 Council concurred and approved M. F. Ronca & Sons, Inc.'s Change Order No. 27 in the aggregate amount of \$88,787.72.

The project includes a new aeration basin and the associated above ground air supply piping. The air supplied by the turbo blowers is compressed and heats up in the process. Therefore, the piping has to balance the expansion and contraction via a specialized support system. GHD conducts routine construction phase QC inspections. During the last one in April, GHD identified opportunities to further reduce pipe stress and increase service life summarized in the attached RFP-081. The additional made to order components were administratively authorized after review of preliminary pricing to maintain the project schedule. On June 6, 2023, Council approved M. F. Ronca & Sons, Inc.'s Change Order No. 28 in the amount of \$108,583.52.

During the start-up of the upgraded mechanical plant pump station a one-time pressure transient was experienced. In an abundance of caution GHD recommended under RFP-088 to replace the gauge with a pressure transmitter in the same location. M. F. Ronca & Sons, Inc. proposes to install the modified tap and piping for \$1,656.00.

The original project bid included a complex winch system moving biosolids containers back and forth under the belt press shoots to allow for uniform loading. Staff has been operating the regional biosolids system for two years and found the occasional moving of the containers to be unproblematic. This allows for the elimination of the winch system under RFP-088. M. F. Ronca & Sons, Inc. proposes a credit of (-\$282,145.60).

On July 18, 2023, Council approved Change Order No. 29 for M. F. Ronca & Sons, Inc. in the aggregate credit amount of (-\$280,489.60).

Environmental Services initiated RFPs-096 & 098. The first creates a hydraulic bypass for each of the two effluent filter banks allowing part of the filtration system to stay in operation during maintenance. The second one deals with the replacement of the compromised 40-year-old LTS Digester Building roof. M. F. Ronca & Sons proposes to accomplish the tasks for \$68,284.99 and \$24,675.00 respectively.

The original bid contains a walkway from the mechanical building to the equalization tanks. It was in part supported by the original parapet wall. When the wall cap was removed it was

determined that the wall was completely compromised and had to be rebuilt. M. F. Ronca & Sons is proposing to complete this task for \$71,547.30.

The original bid only contained trench hot mix restoration resulting in a patchwork of pavement conditions as depicted on the attachment. The Engineering Department requested the contractor to provide an alternate road reclamation based base course proposal combined with a site wide 2-inch hot mix overlay. M. F. Ronca & Sons agreed to limit the mark up on the cost delta only and is proposing to complete this task for \$149,674.16.

On September 12, 2023, Council approved Change Order No. 30 in the aggregate amount of \$314,181.45.

The original bid contained a \$315.00 per ton unit cost for grit removal & disposal from the existing aeration basins. The bid quantity was based on pictures provided by Environmental Services, but the actual quantity is close to three times the estimate. Therefore, the Engineering Department and M. F. Ronca developed an alternate on-site grit storage approach which as a side benefit provides for new aeration diffusers in the existing tanks at a \$219.61 per ton unit price. On September 12, 2023 Council's concurred with the modified unit cost pricing of item C-6 Grit Removal.

The FY24 environmental services budget contains \$75k funding for the repair of the existing influent screen. The quotation for the parts alone amounted to >\$30K, once the labor and crane services were added the repair far exceeded 50% of the new screen offered by M. F. Ronca & Sons at \$89,762.10. A replacement screen will match the new one provided under the project and will represent the better asset value over the service life.

The project includes a full rebuild of the existing four-cell Effluent Filter No. 2. The project included removing the sand from cell one and stockpiling it while using sand from cell two to refill cell one and so on. Once the filter cells were drained it became apparent that approximately 40% of the sand had been lost in the backwash process over the last twelve years. M.F. Ronca & Sons proposed to utilize the County's bagged sand on site in combination with additional manufacturer supplied sand and complete the process in one step rather than four. The contractor can streamline the labor, speed up the process and agreed not to mark up the supplemental sand. M.F. Ronca & Sons offer of \$142,745.34 includes hauling costs but landfill fees will be paid directly by the County at the discounted rate.

The County requested HVAC equipment and control replacements under RFPs 093 & 095 for three of the original 1970s smaller buildings. All of the units have been repaired before and are not fully functional. M.F. Ronca & Sons proposes to perform the replacements and mechanical tie-ins for \$56,155.84.

On October 17, 2023, Council approved Change Order No. 31 in the aggregate amount of \$288,663.28.

Upon the request of Environmental Services Ronca priced out additional switches (i) two (2) Hydraulic Oil Pressure Switches for the belt filter press per RFP-110 (ii) four (4) Blower Inlet Isolation Valve Limit Switches per RFP-111 and (iii) two (2) Conveyor Pull Cord emergency shut off switches. On February 6, 2024, Council approved Change Order No. 32 to M.F. Ronca & Sons in the aggregate amount of \$16,608.23.

The South Coastal project essentially duplicates the almost twenty-year-old gravity filter arrangement. All the actuated control valves in the process are pneumatic due to the high moisture environment which is not conducive to electrical actuation. The Environmental Services team brought to the Department's attention that the pneumatic control system is nearing the end of its service life which was confirmed by GHD the County's consultants. Therefore, they solicited a proposal from M.F. Ronca & Sons under RFP-112 for the in kind replacement. On February 20, 2024, Council approved M.F. Ronca & Sons' Change order No. 33 in the amount of \$62,212.29

A nuisance alarm issue from an e-stop arose during the operation of the new sludge conveyor. Due to differing software versions, Serpentix the manufacturer was 'unable to remotely connect to its control panel in the sludge building triggering a return site visit to add a delay timer to the alarm and programming changes to the control system. M. F. Ronca & Sons proposed to address the issue at a cost of \$5,750.00.

In October of 2023 GHD issued RFP-105 affecting the as bid headworks odor covers. Changes in channel geometry arising from the extensive concrete repair work completed under a previous change order require sections of the odor control covers upstream and downstream and the manual bar screen, and over the screened effluent channel to be replaced. M. F. Ronca & Sons proposed to address the issue at a cost of \$46,943.00.

In the spring of 2024 GHD issued RFP-115 modifying the compressed air piping. EnviroMix, the manufacturer provided two regulators for the compressed air system, intended to be placed at each of the receiver tanks. EnviroMix wanted to set a lower value for maximum allowable compressed air pressure than that stated in the specifications. Despite an attempt to manage both regulators through carefully selected settings, nuisance alarms continue to plague operations. Therefore, a piping change was requested moving the regulators in more stable locations. M. F. Ronca & Sons proposed to address the issue at a cost of \$ 3,124.09.

In the fall of 2023, the sludge dewatering operations resumed. However, a temporary forcemain had to be laid allowing decant and dewatering filtrate to be returned to the Mechanical Building pump station when peak flows exceeded the capacity of the existing primary force main and recycle systems. Under RFP-116 GHD asked the contractor to replace this temporary line with a permanent force main. M. F. Ronca & Sons proposed to address the issue at a cost of \$ 26,166.34.

In addition, Michael F. Ronca & Sons, Inc.'s submitted a no cost contract time extension request of Three Hundred Eighty Two (382) Calendar Days, thereby extending the current substantial completion date to from September 13, 2023 to September 30, 2024, and final

completion date from December 14, 2023 to December 30, 2024. The Department reviewed the back-up documentation and concurred with the requested number of days.

On June 4, 2024, Council approved Change Order No. 34 in the aggregate amount of \$81,983.43 as well as the revised completion dates.

Later on, in June of 2024, unit 1 of the two clarifier drives at the Inland Bays RWF failed. The permanent replacement of unit 1 with a new identical unit, refurbishment, and reinstallation of refurbished drive for unit 2 was covered under RFP-117a. M.F. Ronca & Sons performed two similar repairs at the Inland Bays RWF under Change Order 20 for the influent screens and under a direct purchase order for the dryer unit bearing maintenance. Therefore, Council issued Change Order No. 35 in the amount of \$121,235.07 on July 16, 2024.

Electrical Construction Project C19-17; awarded on December 17, 2019, to BW Electric, Inc.

On February 4, 2020, Council awarded Change Order No.1 in the credit amount of (\$759,374.80) mostly for changes to the conduit materials. A second credit change order was approved on March 10, 2020, in the amount of (\$6,800.00) for ductbank modifications.

On April 7, 2020, Council approved Change Order No.3 in the not to exceed amount of \$235,637.33 for DP&L requested changes to the utility power service entrance location at the RBWTP.

On May 12, 2020, Council authorized Change Order No.4 in the amount of \$11,350.00 for reconstruction of the original electrical equipment in South Coastal's sludge handling building electrical room.

On July 28, 2020, Council approved Change Order No.5 in the combined amount of \$37,830.00 for the removal of an existing electrical handhole and duct bank and the modification of the duct bank between the DP&L utility switching pedestal and the transformer.

On September 22, 2020, Council approved Change Order No.6 in the amount of \$16,550.00 for the change of the sewer service for the return sludge building No. 2 from a gravity drain to a pumped approach.

On September 22, 2020, Council approved Change Order No. 7 in the not to exceed amount of \$307,300.00 for the City's oxidation ditch complete electrical equipment replacement. This change order had an allowance for sensor replacements which proved too low and required an increase of \$6,582.80. Council approved the modification to Change Order No. 7 on November 10, 2020.

On November 10, 2020, Council approved Change Order No. 8 in the aggregate amount of \$2,249.00 covering RFP-027, RFP-028, RFP-029 & RFP-030. GHD has concluded that RFP-

029 can be rescinded in its entirety. Therefore, the scope of work in the Sludge Building reverts to the Drawings, as modified by Change Order No. 4 associated with RFP-016. However, on December 15, 2020, Council approved the modification reducing Change Order No. 8 by \$9,040.00 for a modified net total credit of (\$6,791.00).

On February 9, 2021, Council approved Change Order No. 9 in the aggregate amount of \$30,554.00 covering RFPs-032 & 033. The first RFP provided upsized control panels, conduit and conductors associated with the two (2) Jet Mixing Pump VFDs while the second dealt with a modified temporary electrical feeder arrangement and a redirection of the medium voltage loop.

On August 10, 2021, Council approved Change Order No. 10 in the aggregate amount of \$7,320.00 covering RFP- 035 for waterproofed convenience receptacles at the return sludge building's pump room and RPP-040 for additional site lighting in the area of the generator and blower buildings.

On October 12, 2021, Council approved Change Order No. 11 in the aggregate amount of \$47,328.70 covering the City's initiated RFPs-042 & 44. The first one replaces the deteriorated pull box at building B-10 with a stainless steel one and the second one addresses modifications to the garage feeder.

Also on October 12, 2021, Council approved Change Order No. 12 in the amount of \$4,779.38 covering RFP-045 for modification to the aeration basin lighting out of operational safety concerns.

On January 11, 2022, County Council issued Change Order No. 13 in the aggregate amount of \$20,018.56 for City initiated RFPs -043 & 049. The first one relates to the electrical control requirements for a booster pump in Building T-1. The second one addresses rewiring of the two (2) level sensors and dissolved oxygen probes at the oxidation ditches.

Also On January 11, 2022, County Council issued Change Order No. 14 in the credit amount of (\$6,485.87) for the elimination of four valve actuators.

The City's lighting in the headworks building and the panelboard in the chemical building are compromised by corrosion and City staff requested replacement as per RFP-050. The County Environmental Services and IT staff reanalyzed the facility's fiber optic cabling needs and requested inner duct modifications under RFP-059. BW Electric proposed to make the changes for \$12,018.72 and \$16,100.70 respectively and on February 8, 2022, Council issued Change Order No. 15 in the aggregate amount of \$28,119.42.

On March 29, 2022, County Council issued Change Order No. 16 in the aggregate amount of \$52,003.13 for the DP&L metering modifications at the City's plant and dedicated VFD cabinet ventilation.

The following RFPs were requested by Environmental Services:

1. RFP-064 for float-controlled effluent pump backup control panel in the event of a failure in the digital pump control system or level transmitter in the amount of \$29,895.13.
2. RFP-065 for the demolition and replacement of the original 1970s lighting in the Headworks Pump Room, Headworks Grit Dewatering Room, Mechanical Building Pump Room, and outdoor wallpacks around perimeter of Mechanical Building in the amount of \$80,099.11.
3. RFP-066 for additional circuits and conduits associated with a conveyor warning alarm in the Cake Storage Building, and for separation of 120 VAC circuits from 24 VDC circuits originating in Cake Storage Building in the amount of \$3,090.30.
4. RFP-068 for the electrical work associated with replacing the compressed gas mixing system with a mechanical mixing system in the amount of \$83,738.84. This is the companion change order to Michael F. Ronca & Sons' Change Order No. 21 for the mechanical work.
5. RFP-069 for a change in the existing 6-way DB-5A allowing for the MH-47 to be eliminated at a credit of (\$7,500.00).

On May 10, 2022, Council approved BW Electric, Inc.'s Change Order No. 17 in the aggregate amount of \$189,323.38.

The pumps and rail systems in the existing filtrate return pump station were upgraded under Change Order No. 18 by M. F. Ronca & Sons. RFP-060 covers the electrical and control upgrades associated with that station. This work was not part of the original plant upgrade scope. BW Electric, Inc. proposed to complete the work for \$92,713.82. In order to address operator safety and access cameras, as well as network access points, proposals were requested at aeration tanks 5-8 requiring a series of additional conduits and pull boxes. BW Electric, Inc. proposed to complete the work for \$50,362.91. On June 7, 2022, Council approved Change Order No. 18 to BW Electric, Inc in the aggregate amount of \$143,076.73.

Provide a credit proposal to remove the Off-Site Manufacturer Course Training specified in the construction documents. This will be conducted as part of the startup process resulting in a credit of \$17,758.13. On October 11, 2022, Council approved Change Order No. 19 in the amount of \$17,758.13.

On October 11, 2022, Council approved M. F. Ronca & Sons' Change Order No. 25 for the SCRWF for improvements to the headworks ventilation. GHD issued the companion RFP-077 for the odor control electrical modifications. In response BW Electric, Inc. proposed to complete the work for \$19,401.62.

GHD also issued companion RFP-076 for the electrical components associated with City's State Street pump station repair scope. In response BW Electric, Inc. proposed to complete the work for \$462,938.82. The City has concurred in the issuance and again will pay for this change order directly out of city funds with separate invoice by the electrical contractor.

On December 6, 2022, Council approved Change Orders No. 20 in the amount of \$19,401.62 & 21 in the amount of \$462,938.82 to BW Electric, Inc. for the headworks ventilation and the expanded State Street Pump Station electrical repair scope. The latter paid for by the City via direct reimbursements to the contractor.

BW Electric, Inc. submitted RFI-102 questioning the absence of a neutral bonding conductor in the electrical feeder 5A. GHD investigated the information request and concluded that the least costly solution to achieve the NEC required bonding was to add a conductor. Since this was an omission in the original documents, all of GHD's work associated with this item was not billed. On March 21, 2023 Council concurred and approved BW Electric's Change Order No. 22 in the amount of \$33,342.10.

The following RFPs were requested by Environmental Services:

1. RFP-082 deals with now required generator building feeder replacement since the "spare" shown on record drawings turned out to be already occupied. BW Electric proposes to complete the task for \$4,736.24.
2. RFP-083 for the shop feeder conductor replacements required due County's equipment changes. BW Electric proposes to complete the task at no cost.
3. RFP-084 covers the complete replacement of original 1970s lagoon sludge lighting system. It is largely inoperative, and the poles and fixtures are heavily corroded. BW Electric proposes to complete the task for \$86,480.73.
4. RFP-085 for the welder receptacles upgrades. BW Electric proposes to complete the task at no cost.
5. RFP-087 for the electrical components and signal wiring associated with the pressure sensor in the mechanical pump station. This is the electrical companion scope to Michael F. Ronca & Sons' RFP-088 for the mechanical work. BW Electric proposes to complete the task for \$10,340.23.

On July 18, 2023, Council approved Change Order No. 23 for BW Electric, Inc. in the aggregate amount of \$101,557.20.

BW Electric priced RFP-089 for the electrical credit associated with the winch system elimination at (\$10,134.30). In addition, an electrical safety issue at the SC administration building was identified under RFP-091. It required removing the existing PLC cabinet located in the Administration Building's electrical room, and replacing it with a new PCS cabinet, PCS-AB in its place. BW Electric has now priced RFP-091 at \$68,103.21. The last RFP-092 was associated with HVAC related issues in the Sodium Hypochlorite Building electrical room replacing it with a new power circuit and DS for a heat pump as well as providing new outdoor receptacle and associated power circuit. BW Electric has priced RFP-092 at \$8,554.77. The General Contractor is still pricing the mechanical components under RFP-093.

On August 1, 2023, Council approved BW Electric, Inc.'s Change Order No. 24 in the aggregate amount of \$66,523.68.

The County requested HVAC equipment and control replacements under RFPs 093 & 095 for three of the original 1970s smaller buildings. All the units have been repaired before and are not fully functional. On October 10, 2023 Council approved M.F. Ronca & Sons' proposal to perform the replacements and mechanical as part of Change Order No. 31. RFP-094 addresses the electrical side of these HVAC improvements. On December 5, 2023, Council approved BW Electric, Inc.'s Change Order No. 25 in the aggregate amount of \$17,939.03.

The Environmental Services staff requested a new exterior a freestanding EMR for the sludge building between the overhead doors. Council approved BW Electric, Inc.'s Change Order No. 26 in the amount of \$9,636.87 on February 6, 2024.

Under M.F. Ronca & Sons' Change order No. 33 Council approved the pneumatic control system replacement for the existing filter which was at the end of its service. Therefore, GHD issued RFP-114 to BW Electric, Inc. for five (5) new equipment cabinet power circuits, four (4) existing pole mounted light fixtures circuits and various receptacles all mounted on Effluent Filter No. 2. On June 4, 2024, Council approved BW Electric, Inc's Change Order No. 27 in the aggregate amount of \$20,137.99.

- e. Mobile Belt Filter Press; awarded on January 7, 2020, Council to Kershner Environmental Technologies. The unit is currently stationed at South Coastal in anticipation of the aeration basin transfer.
- f. DP&L direct expenses; on February 4, 2020, Council approved the electric utility service relocation contract with the utility.
- g. The Rehoboth Beach WTP was built on a municipal landfill and Council approved a stand-alone competitive purchase order to Melvin L. Joseph Construction Company, Inc. for material hauling & screening on July 14, 2020.

The updated expenses associated with the South Coastal WRF Treatment Process Upgrade No.3 & Rehoboth Beach WTP Capital Improvement Program; Phase 2 are summarized in the attached spreadsheet.



15342 S. DuPont Hwy
Harrington DE 19952

Office: 302.566.6248
Fax: 302.566.6251

Bryon Warren
President
302-270-5719

Email(s):
office@bwelectricinc.com
estimates@bwelectricinc.com

October 22, 2024

Subject: SCRWF Upgrade No. 3 & RBWWTP CIP Upgrade Phase 2 RFP No. 118

Dear Mr. Medlarz,

Our price to perform the electrical work associated with the above project is based on RFP No. 118. Our price does not include the use of Prevailing Wages. Our price is **\$15,855.64** and includes the following:

Description of proposed changes

1. A new rectifier of the same specifications as the existing rectifier shall be procured and installed in the location of the existing rectifier utilizing the existing AC service and connected to the existing cathodic protection system. Per "South Coastal Regional Wastewater Facilities Ocean Outfall As-Built Drawings Contract No. C-10-109-1" dated February 25, 1976, Reference Detail B/Sheet 9 and Bill of Materials Sheet 11 Item 1: "Cathodic Protection Rectifier – Single Phase, Oil Cooled, 30V, 34A, with lightning arrestors on input and output. Case to be hot dip galvanized. Good-All Ordering Code – CSOWSA 30-34 EN. Or approved equal."
2. It is the Contractor's responsibility to verify the type and specifications of the existing rectifier including output rating, input voltage and phase, and compatibility of AC service prior to ordering replacement.
3. Catalog cuts for the proposed replacement rectifier shall be submitted to the County for review and approval prior to ordering.
4. The existing rectifier shall remain in service until the replacement rectifier arrives at the project site and is ready for installation.
5. The existing oil-cooled rectifier shall be removed from service and properly disposed of or recycled in accordance with any/all local, regional, state, federal, or other

regulations/guidelines related to disposal of said type of equipment. It is the Contractor's responsibility to comply with all regulations governing the handling, transportation, and disposal of said rectifier.

6. The new rectifier shall be mounted in the same manner and location as the existing rectifier. Hardware and miscellaneous materials required related to mounting are the Contractor's responsibility. The Contractor may visit the existing rectifier site prior to bidding in order to determine mounting requirements.
7. Following mounting and landing of AC service, the existing positive and negative cables shall be connected in order to achieve functionality with the existing CP system. Additional measures if necessary to achieve cathodic protection system functionality are solely the responsibility of the Contractor.
8. The rectifier tap settings shall be adjusted in order to achieve a DC current output approximately matching the DC adjusted DC current output per the October 20, 2023 cathodic protection system survey (by others) of 4.56 Amperes. The tap settings and DC current and voltage output shall be recorded and submitted to the County.
9. Site restoration and clean-up as necessary shall be conducted to completely restore the project site to the existing condition prior to completion of the project.

If this RFP is accepted, we are requesting 5 days be added to the contract.

Exclusions

1. No permit fees.
2. No cutting.
3. No patching or painting.
4. No liquidated damages.

This price is good for thirty (30) days only.

Sincerely,

Jason R. Walters
B. W. Electric, Inc.
Superintendent
JRW/

#SCRWF Upgrade No.3 and RBWWTP CIP Upgrade Phase 2 : RFP No. 118
Totals (Summary) - Bid Summary: Default

Material	
Non-Quoted	\$3,750.00
Quotes	5,163.00
Sales Tax (0.00%)	0.00
Total Material	\$8,913.00
Labor	
Direct (56.00 hours @ \$80.00)	\$4,480.00
Non-Productive Labor	0.00
Total Labor (56.00 hours)	\$4,480.00
Direct Job Expenses	\$0.00
Tools and Miscellaneous Materials	0.00
Subcontracts	0.00
Job Subtotal (Prime Cost)	\$13,393.00
Overhead (10.00%)	1,339.30
Profit (5.00%)	736.62
Job Total	\$15,468.92
Bond	
Bond	386.72
Job Total with Bond	\$15,855.64
Actual Bid Price	\$15,855.64
Material to Direct Labor ratio: 0.67	
Prime Cost per square foot	\$0.00
Job Total per square foot	\$0.00
Actual Bid Price per square ft	\$0.00
Labor cost per square foot	\$0.00
Labor hours per square foot	0.00
Gross Profit %	15.53
Gross Profit \$	\$2,462.64
Net Profit %	7.08



13715 N. Promenade Blvd | Stafford, TX. 77477
 Ph: (281) 879-9903 Fax: (281) 879-9913
 Email: mgrace@jaelectronics.com
www.jaelectronics.com

Quote #: 2241000-Q

Inquiry: 10-14-2024
 Date: 10-16-2024
 Quote Valid: 30 Days

Quoted To: BW Electric

Attn: Jason Walters
 Ph #: (302) 222-8734 Cell
 Email: jason@bwelectricinc.com

Routing: Best Way / PP&A
 Lead Time: 11-13 Weeks ARO
 FOB: Destination
 Terms: Credit Card

- GHD Project No.: 11121182 -

1). Quantity = 1 ea.

JA Elec. Custom “NON-Classified” OIL cooled, PAD mounted, T/R rated for **30 volts @ 34 amps DC**; 120/240v, 50 Hz, SINGLE-PHASE input, pre-wired for **240vac**; **6 COARSE & 6 FINE** output taps[36 STEPS] adjust settings; 1-Phase Silicon Modular full-wave bridge[0-50A] with AC & DC surge suppressors(**MOV's**); Slide-out transformer/stack rack assemblies; **NO Filter Choke** provided; Combination AC/DC Lightning Arrestor [LA104]; **2-POLE** AC circuit breaker; Separate Hoyt Model 582 analog DC Volt & Amp meters; AC Secondary, DC Negative & spare high speed rectifier **FUSES**; **No** 115vac convenience outlet; **(1)NEGATIVE & (1)POSITIVE** terminals, with individual **50mv = 40amp** shunt with 5-Way Binding Posts; All current carrying hardware to be MARINE GRADE BRASS/SILICON BRONZE & all mounting hardware to be STAINLESS STEEL; “**PMO-SS-1**” Enclosure fabricated from **0.125 5052-H32 “Marine Grade” Aluminum** & is Dry Powder Painted “**White**”; Hinged/gasketed Oil Compartment lid, with (2 ea) heavy duty electro-polished Stainless Steel draw-pull latches; Control Compartment with hinged door & (1 ea) heavy duty electro-polished Stainless Steel draw-pull latch; **(1 ea) 1” AC** conduit entry in center bottom of Control Cabinet & **(2 ea) 1” DC** Conduit Entries in control cabinet under DC Outputs; Enclosure rated for “Non-Classified” Environments; Mfg. as per limited details provided & features are LIMITED TO DETAILED DESCRIPTION above.

➤ **UNIT WILL TAKE APPROXIMATELY 21 GALLONS OF OIL.**
PN: PMOPY30-34DAABCKOZ (White)

Unit Price = \$ 5,163.00 /ea.

We appreciate the opportunity...

Michael Grace

10-16-2024

Quoted By:

Date:

Surcharge Notice: BrandSafway imposes a surcharge of 3% on the transaction amount if a credit card is used for payment. This surcharge does not apply to debit cards and is not greater than our rate of acceptance.

THIS MESSAGE IS INTENDED ONLY FOR THE USE OF THE INDIVIDUAL, OR ENTITY, TO WHICH IT IS ADDRESSED, AND MAY CONTAIN INFORMATION WHICH IS PRIVILEGED, CONFIDENTIAL, AND EXEMPT FROM DISCLOSURE UNDER APPLICABLE LAW. IF THE READER OF THIS MESSAGE IS NOT THE INTENDED RECIPIENT, OR PERSON RESPONSIBLE FOR DELIVERING THE MESSAGE TO THE INTENDED RECIPIENT, YOU ARE HEREBY NOTIFIED THAT ANY DISSEMINATION, DISTRIBUTION, OR COPYING OF THIS COMMUNICATION IS STRICTLY PROHIBITED. IF YOU HAVE RECEIVED THIS COMMUNICATION IN ERROR, PLEASE NOTIFY US IMMEDIATELY BY TELEPHONE. THANK YOU.



Request for Proposal

Project Title	SCRWF Upgrade No. 3 & RBWWTP CIP Upgrade Phase 2		
Owner	Sussex County, Delaware		
Contract No.	C19-17: Electrical Construction	GHD Project No.	11121182
Contractor is requested to provide a Change Proposal for the following proposed modifications to the Work. This request alone neither directs nor approves any change to the Work nor any adjustments to the Contract Price or Contract Times. Contractor's proposal shall be submitted to Engineer for review and shall adhere to all requirements of the Contract Documents. If found acceptable to Owner and Engineer, Contractor's Change Proposal will be incorporated into the Work via Change Order.			
RFP No.	118		
RFP Subject	SCRWF Ocean Outfall Rectifier Replacement		
Issued By	J. Knauer	Issue Date	Sep. 19, 2024

Description of proposed changes:

1. A new rectifier of the same specifications as the existing rectifier shall be procured and installed in the location of the existing rectifier utilizing the existing AC service and connected to the existing cathodic protection system. Per "South Coastal Regional Wastewater Facilities Ocean Outfall As-Built Drawings Contract No. C-10-109-1" dated February 25, 1976, Reference Detail B/Sheet 9 and Bill of Materials Sheet 11 Item 1: "Cathodic Protection Rectifier – Single Phase, Oil Cooled, 30V, 34A, with lightning arrestors on input and output. Case to be hot dip galvanized. Good-All Ordering Code – CSOWSA 30-34 EN. Or approved equal."
2. It is the Contractor's responsibility to verify the type and specifications of the existing rectifier including output rating, input voltage and phase, and compatibility of AC service prior to ordering replacement.
3. Catalog cuts for the proposed replacement rectifier shall be submitted to the County for review and approval prior to ordering.
4. The existing rectifier shall remain in service until the replacement rectifier arrives at the project site and is ready for installation.
5. The existing oil-cooled rectifier shall be removed from service and properly disposed of or recycled in accordance with any/all local, regional, state, federal, or other regulations/guidelines related to disposal of said type of equipment. It is the Contractor's responsibility to comply with all regulations governing the handling, transportation, and disposal of said rectifier.
6. The new rectifier shall be mounted in the same manner and location as the existing rectifier. Hardware and miscellaneous materials required related to mounting are the Contractors responsibility. The Contractor may visit the existing rectifier site prior to bidding in order to determine mounting requirements.
7. Following mounting and landing of AC service, the existing positive and negative cables shall be connected in order to achieve functionality with the existing CP system. Additional measures if necessary to achieve cathodic protection system functionality are solely the responsibility of the Contractor.
8. The rectifier tap settings shall be adjusted in order to achieve a DC current output approximately matching the DC adjusted DC current output per the October 20, 2023 cathodic protection system survey (by others)



of 4.56 Amperes. The tap settings and DC current and voltage output shall be recorded and submitted to the County.

9. Site restoration and clean-up as necessary shall be conducted to completely restore the project site to the existing condition prior to completion of the project.

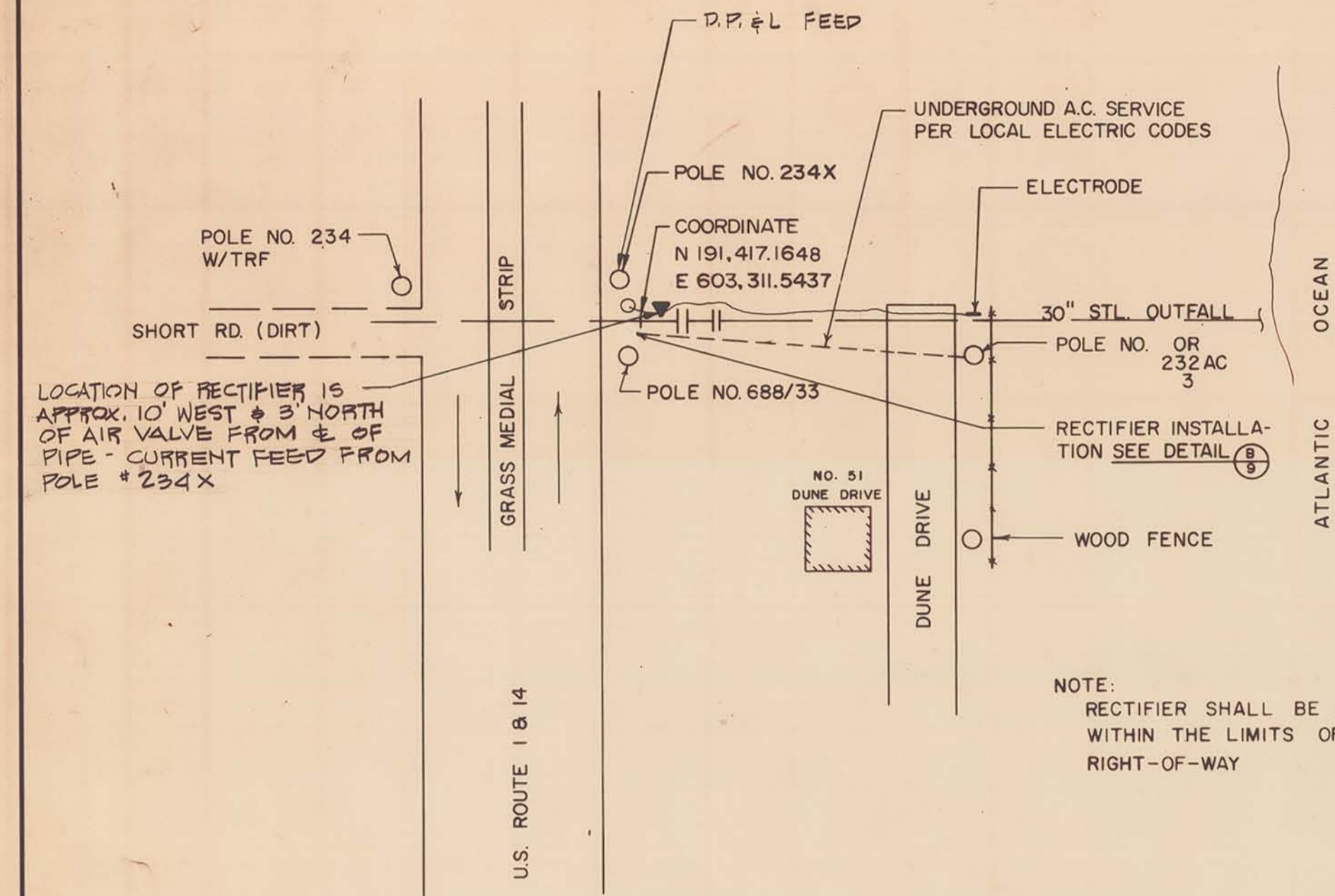

DETAIL A
RECTIFIER LOCATION

NOTE:
CONTRACTOR SHALL PROVIDE ELECTRICAL SERVICE FOR RECTIFIER OPERATION AS REQUIRED

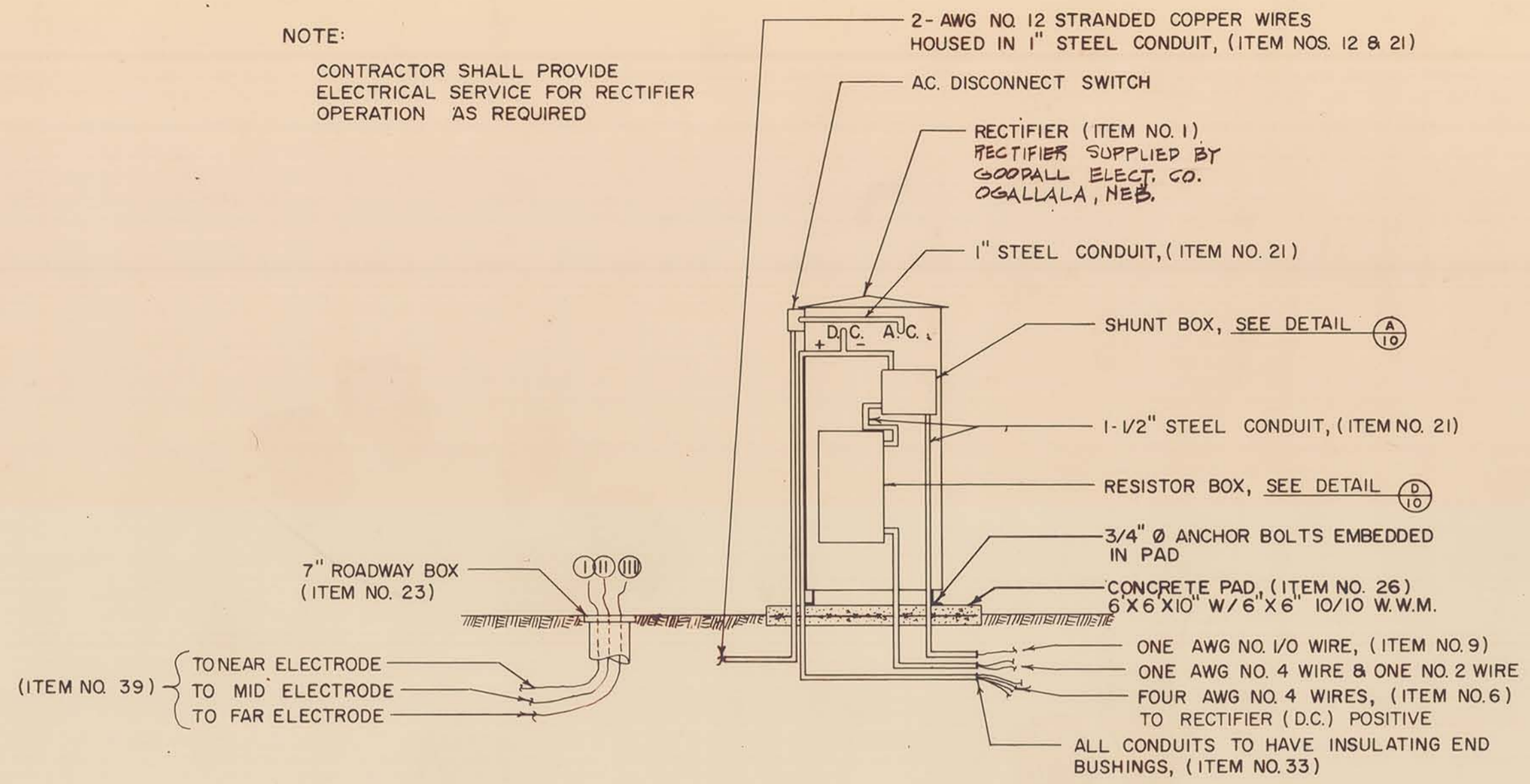

DETAIL B
RECTIFIER INSTALLATION
APPROX. 10' WEST & 3' NORTH OF AIR RELEASE VALVE - FEED FROM D.P. & L POLE # 234X

- NOTES:
- EXCAVATE A 6' X 18' AREA TO A POINT 8' BELOW THE OCEAN FLOOR
 - LOWER IN ANODE ASSEMBLY VERY CAREFULLY, AS ANODES ARE BRITTLE
 - BACKFILL WITH EXTREME CARE WITH NATURAL DITCH SPOIL FREE FROM ROCKS AND SHARP OBJECTS.
 - ALL TIMBER TO BE PRESSURE TREATED WITH 0.6 PC.F. CHROMATED COPPER ARSENATE.

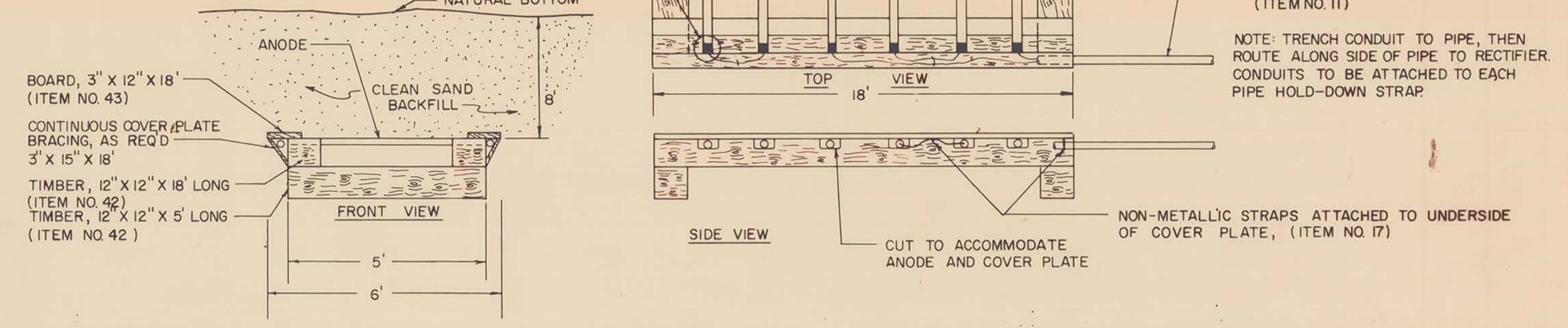

DETAIL C
ANODE ASSEMBLY

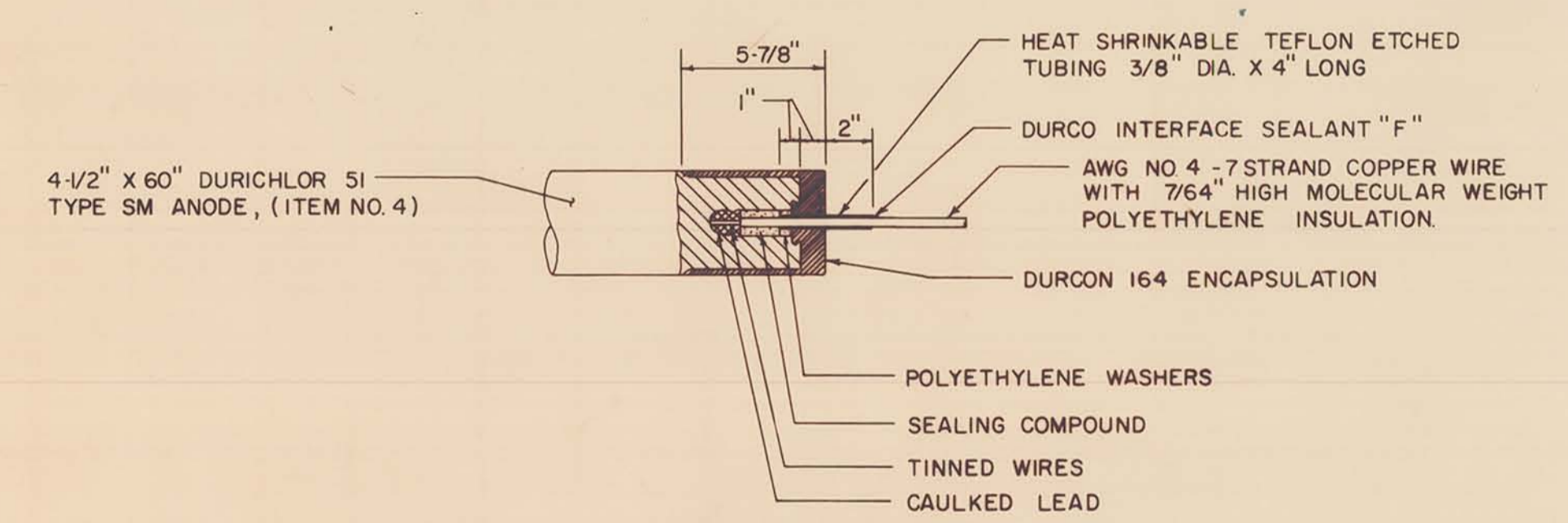

DETAIL D
ANODE TO CABLE ENCAPSULATION

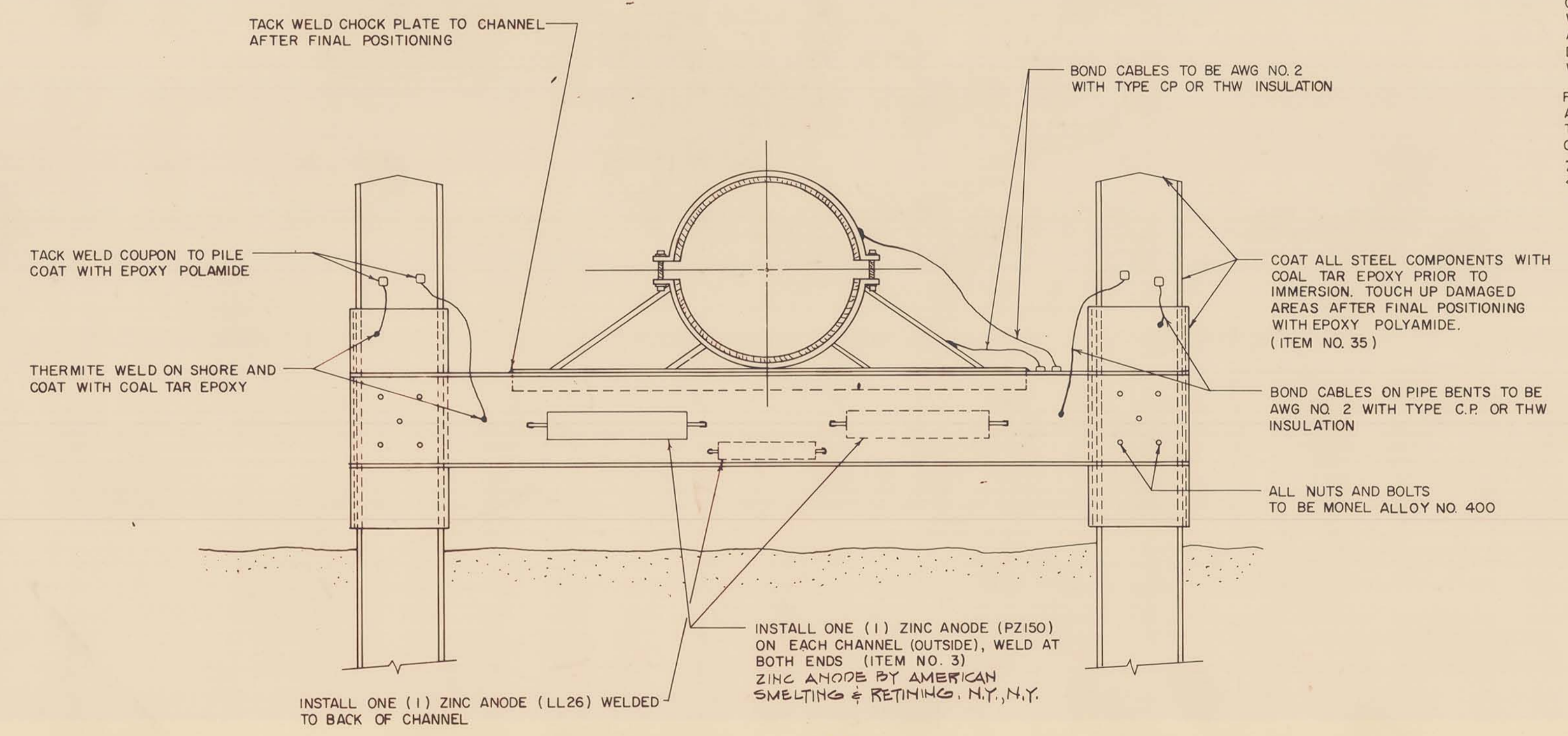

DETAIL E
PILE BENT ASSEMBLY
SEE CHANGE SHOP DRAWING SHEET 6 OF 11

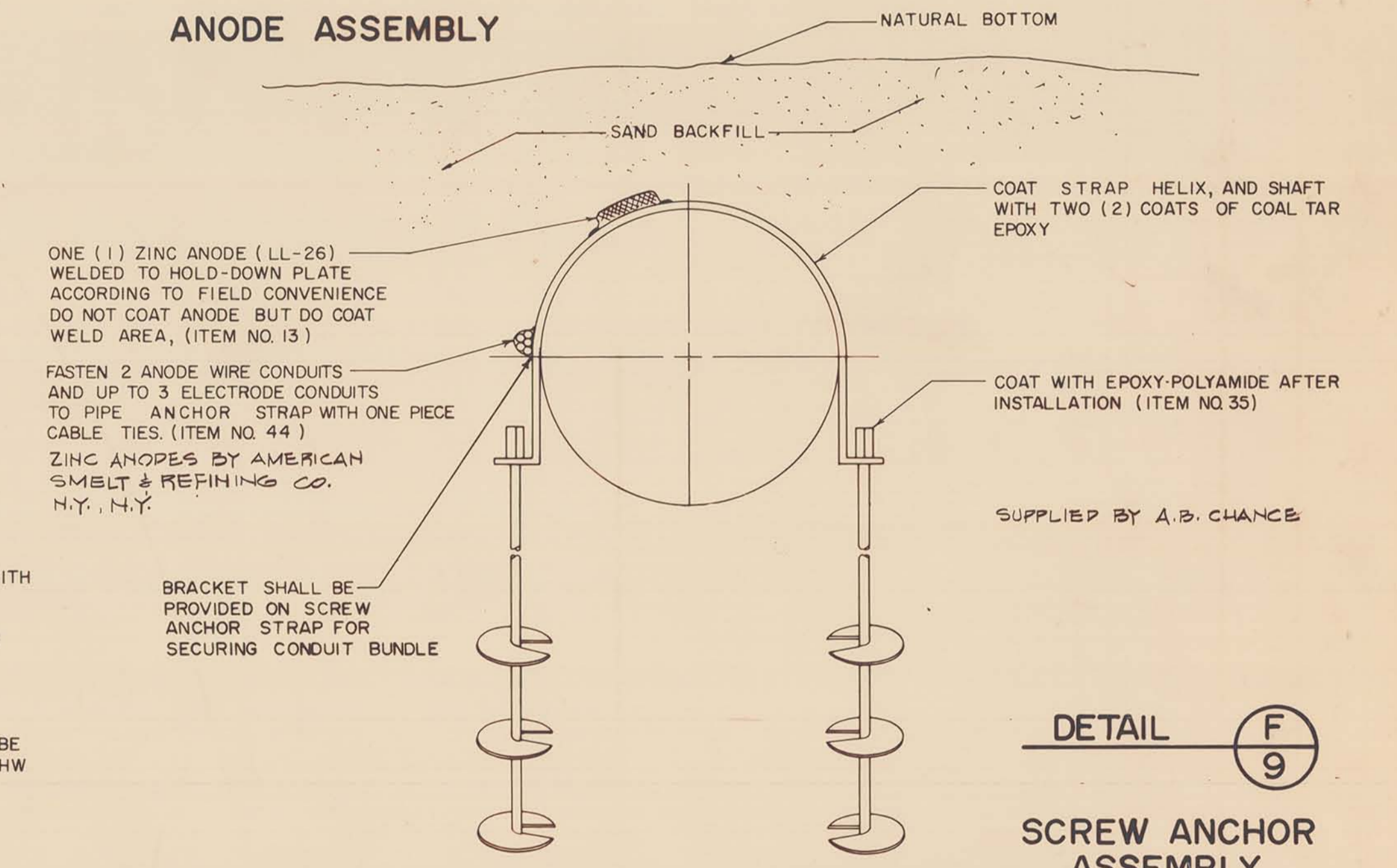

DETAIL F
SCREW ANCHOR ASSEMBLY

AS BUILT CORROSION CONTROL
OCEAN OUTFALL
SOUTH COASTAL REGIONAL WASTEWATER FACILITIES
SUSSEX COUNTY, DELAWARE

John Wagner
DRAWING PREPARED BY
A. V. SMITH ENGINEERING COMPANY
NARBERTH PENNA.

THIS DRAWING DOES NOT INCLUDE NECESSARY COMPONENTS FOR CONSTRUCTION SAFETY
ALL CONSTRUCTION MUST BE DONE IN COMPLIANCE WITH THE OCCUPATIONAL SAFETY AND HEALTH ACT OF 1970 AND ALL RULES AND REGULATIONS THEREOF APPURTINANT.

REVISIONS	CHECKED BY DATE

EDWARD H. RICHARDSON ASSOCIATES, INC.
CONSULTING ENGINEERS
NEWARK, DELAWARE

APPROVED BY: *John Wagner*

THIS DRAWING AND THE DESIGN FEATURES OR CONSTRUCTION DISCLOSED ARE PROPRIETARY TO EDWARD H. RICHARDSON ASSOCIATES AND SHALL NOT BE REPRODUCED, ALTERED OR COPIED WITHOUT WRITTEN PERMISSION. SHALL NOT BE USED IN ANY MANNER DETRIMENTAL TO ITS INTEREST AND SHALL BE RETURNED UPON REQUEST.

SCALE: NONE
DRAWN BY: W.F.E.
DESIGNED BY: V.J.G.
CHECKED BY: W.W.S.
DATE: 25 FEB. 76
COMM. 834-056-18
FILE NO. F-009
SHEET NO. 9 OF 11

BILL OF MATERIALS (APPROX.)

ITEM	UNIT	QUAN.	DESCRIPTION	POSS. SUPPLIER
1	EACH	1	CATHODIC PROTECTION RECTIFIER - SINGLE PHASE, OIL COOLED, 30 V., 34 A., WITH LIGHTNING ARRESTORS ON INPUT AND OUTPUT. CASE TO BE HOT DIP GALVANIZED. GOOD-ALL ORDERING CODE - CSOWSA 30-34 EN. OR APPROVED EQUAL.	GOOD-ALL ELECTRIC CO. OGALLALA NEBRASKA OR STUART STEEL PROT. CORP. SOUTH BOUND BROOK N.J.
2	EACH	3	ANODE, MAGNESIUM, 32 LB. WITH PACKAGING AND SUFFICIENT AWG NO. 12 SOLID COPPER WIRE TO REACH ROADWAY BOX FROM PIPE LEVEL. DOW GALVOMAG OR APPROVED EQUAL.	STUART STEEL PROT. CORP. OR DOW CHEMICALS
3	EACH	64	ANODE, ZINC, PZ-150 WITH 3/8" GALVANIZED STEEL ROD CORE. FOR PIPE BENT ASSEMBLY.	STUART STEEL PROT. CORP.
4	EACH	2	ANODE ASSEMBLY CONSISTING OF THREE (3) 4-1/2" X 60" DURICHLOR 51 ANODES. FACTORY ASSEMBLED ON 5" SPACINGS TO AN AWG NO. 4 WIRE WITH HIGH MOLECULAR WEIGHT POLYETHYLENE INSULATION AND 3000' EXTENSIONS FROM BOTH ENDS OF EACH SET.	STUART STEEL PROT. CORP.
5	EACH	2	INSULATING FLANGE FOR 30" PIPE.	
6	LIN. FT.	14000±	WIRE, AWG NO. 4, 7 STRAND H.M.W.P.E. INSULATION, 600 VOLT. (PART OF ITEM NO. 4)	BARLOW CORP. PHILA. PA.
7	LIN. FT.	500	WIRE, AWG NO. 4, 7 STRAND H.M.W.P.E. INSULATION, 600 VOLT.	GRAYBAR ELEC. CO. PHILA. PA.
8	LIN. FT.	3500	WIRE, AWG NO. 2, 7 STRAND H.M.W.P.E. INSULATION, 600 VOLT.	GRAYBAR ELEC. CO.
9	LIN. FT.	7000±	WIRE, AWG NO. 1/0 H.M.W.P.E. INSULATION, 600 VOLT.	GRAYBAR ELEC. CO.
10	LIN. FT.	10000±	CONDUIT, 1" NOMINAL P.V.C. FOR WIRE IMBEDDED IN PIPE WEIGHTING.	GRAYBAR ELEC. CO.
11	LIN. FT.	7000±	CONDUIT, 1/2" NOMINAL FLEXIBLE PLASTIC FOR SLEEVING OF AWG NO. 4 ANODE WIRES TO AND FROM ANODE ASSEMBLY.	GRAYBAR ELEC. CO.
12	LIN. FT.	100	COPPER CONDUCTOR SERVICE CABLE, AWG NO. 12, 600 VOLT INSULATION.	LOCAL ELEC. SUPPLIER
13	EACH	141	ANODE, ZINC, LL-26 WITH GALVANIZED WELDING STRAP. FOR ANCHOR ASSEMBLIES AND PIPE BENT INTERIOR.	STUART STEEL PROT. CORP.
14	EACH	1	A.C. SUPPLY 115 VOLT, 60 CYCLE, SINGLE PHASE.	ELECTRIC UTILITY
15	EACH	AS REQ'D	CONNECTING LUGS, T & B "LOCK-TITE" FOR AWG NOS. 2, 4, & 1/0 CABLE OR APPROVED EQUAL.	GRAYBAR ELEC. CO.
16	EACH	AS REQ'D	CONNECTORS, ELBOWS, TEES, ETC. FOR GALVANIZED RIGID STEEL CONDUIT.	GRAYBAR ELEC. CO.
17	EACH	AS REQ'D	NON-METALLIC STRAPS SUITABLE FOR SECURING ANODE CABLE TO WOODEN COVER BOARD.	LOCAL
18	EACH	1	BOX, WEATHERPROOF, HEAVY HOT DIP GALVANIZED, 8" X 8" X 4" MIN. HOPE TYPE H3200 OR APPROVED EQUAL.	GRAYBAR ELEC. CO.
19	EACH	1	BOX, WEATHERPROOF, HEAVY HOT DIP GALVANIZED, 18" X 12" X 6" MIN. HOPE TYPE H3200 OR APPROVED EQUAL.	GRAYBAR ELEC. CO.
20	EACH	2	ASBESTOS MOUNTING PANELS, 7" X 7" X 1/4", FITS ITEM NO. 18 & 17" X 11" X 1/4", FITS ITEM NO. 19	LOCAL
21	LIN. FT.	AS REQ'D	1" & 1-1/2" GALVANIZED RIGID STEEL CONDUIT.	GRAYBAR ELEC. CO.
22	EACH	AS REQ'D	THERMITE WELDING EQUIPMENT AND CHARGES.	GRAYBAR ELEC. CO.
23	EACH	3	7" ROADWAY BOX, UPPER SECTION ONLY WITH COVER FOR GRADE LEVEL TEST STATIONS.	
24	EACH	AS REQ'D	CONNECTOR, COPPER, T & B COMPRESSION "C" TAP FOR AWG NO. 2 & NO. 1/0 CABLE.	GRAYBAR ELEC. CO.
25	EACH	1	CONNECTION BOX, HOT DIP GALVANIZED, 4" X 4" X 3" HOPE TYPE H3200 OR APPROVED EQUAL.	GRAYBAR ELEC. CO.
26	CU. FT.	AS REQ'D	CONCRETE FOR RECTIFIER PAD AND ROADWAY BOXES.	LOCAL
27	EACH	1	RESISTOR, 300 WATT ADJUSTABLE, .31 OHMS, OHMITE "CORRIB" DIVIDOHM NO. 2606 WITH MOUNTING BRACKET OR APPROVED EQUAL.	OHMITE RESISTOR CORP. SKOKIE ILLINOIS
28	EACH	1	RESISTOR, 300 WATT ADJUSTABLE, 1.0 OHMS, OHMITE "CORRIB" DIVIDOHM NO. 2611 WITH MOUNTING BRACKET OR APPROVED EQUAL.	OHMITE RESISTOR CORP.
29	EACH	3	ELECTRICAL SHUNTS, WESTON MODEL 9992, 50 MV 25A CAPACITY OR APPROVED EQUAL.	WESTON ELEC. NEWARK N.J.
30	EACH	4	5/16" X 1" BOLTS AND NUTS FOR RESISTORS (ITEMS 27 & 28)	LOCAL
31	EACH	6	13/16" X 1-1/4" BOLTS AND NUTS FOR SHUNTS (ITEM 29)	LOCAL
32	EACH	8	3/8" X 1" BOLTS AND NUTS FOR ATTACHING MOUNTING PANELS TO BOXES.	LOCAL
33	EACH	AS REQ'D	INSULATING END BUSHINGS FOR ALL CONDUITS	GRAYBAR ELEC. CO.
34	EACH	AS REQ'D	COATING MOLDS, FIELD JOINTER OR APPROVED EQUAL. FOR FLANGES, WELD JOINTS, ETC. ORDER TO FIT.	H.C. PRICE CO. FAIRLESS HILLS PA.
35	GAL.	AS REQ'D	EPOXY RESIN POLYAMIDE COATING WITH 30% EXCESS POLYAMIDE CURING AGENT. SHELL "EPON" OR EQUAL.	SHELL CHEMICAL CO.
36	EACH	AS REQ'D	SPLICING KIT, SCOTCHCAST NO. 85-12 OR APPROVED EQUAL.	STUART STEEL PROT. CORP.
37	EACH	AS REQ'D	ELECTRICAL CONNECTORS	LOCAL
38	EACH	AS REQ'D	ROCK-SHIELD (SEAL-TIGHT, PIPE SHIELD) OR APPROVED EQUAL.	STUART STEEL PROT. CORP.
39	LIN. FT.	7500±	WIRE, AWG NO. 8 STRANDED COPPER WITH 600 VOLT HMWPE INSULATION, FOR ELECTRODE ATTACHMENTS.	GRAYBAR ELEC. CO.
40	EACH	AS REQ'D	CROUSE-HINDS CONDULET, FSD 312 WITH COVER PLATE 51002 OR APPROVED EQUAL.	GRAYBAR ELEC. CO.
41	EACH	1	BRASS BUS BAR 1" X 5" X 1/8"	LOCAL
42	LIN. FT.	46	12" X 12" TIMBER FOR ANODE ASSEMBLY.	LOCAL
43	LIN. FT.	36	3" X 12" WOODEN PLANK FOR ANODE ASSEMBLY.	LOCAL
44	EACH	AS REQ'D	MISCELLANEOUS MATERIALS AND EQUIPMENT NECESSARY TO COMPLETE INSTALLATION.	LOCAL
45	EACH	3	ELECTRODE, 2" X 9" DURICHLOR 51 TYPE G ANODES OR EQUAL (WORK WITH ITEM NO. 39)	STUART STEEL PROT. CORP.

NOTE: QUANTITIES OF MATERIALS AND EQUIPMENT SHOWN ON THIS DRAWING ARE FOR THE CONVENIENCE OF THE CONTRACTOR ONLY AND SHALL NOT RELIEVE HIM OF THE RESPONSIBILITY TO FURNISH AND INSTALL ALL MATERIALS AND EQUIPMENT NECESSARY TO COMPLETE THE WORK.

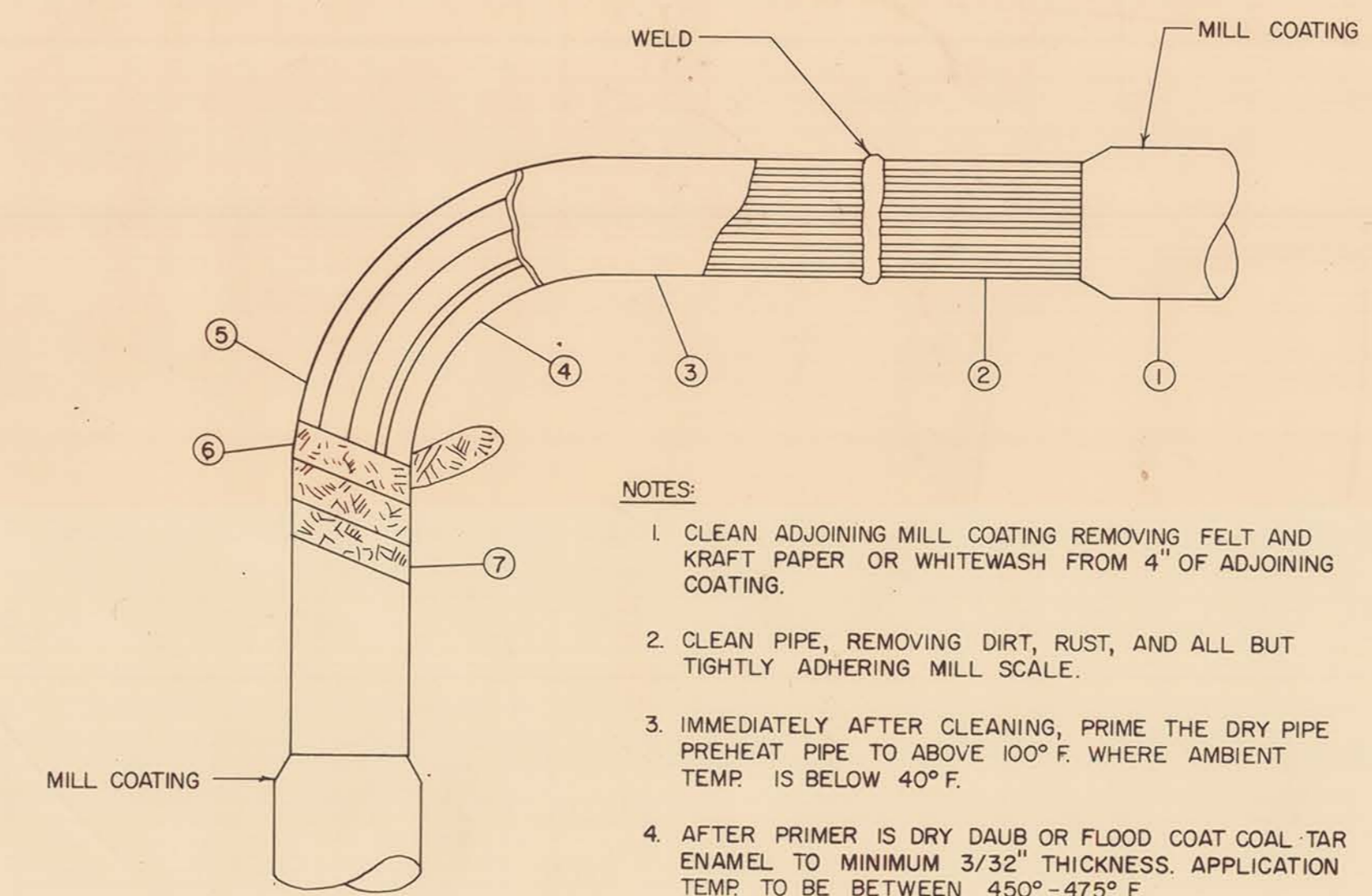

- NOTES:
- CLEAN ADJOINING MILL COATING REMOVING FELT AND KRAFT PAPER OR WHITEWASH FROM 4" OF ADJOINING COATING.
 - CLEAN PIPE, REMOVING DIRT, RUST, AND ALL BUT TIGHTLY ADHERING MILL SCALE.
 - IMMEDIATELY AFTER CLEANING, PRIME THE DRY PIPE PREHEAT PIPE TO ABOVE 100° F. WHERE AMBIENT TEMP. IS BELOW 40° F.
 - AFTER PRIMER IS DRY DAUB OR FLOOD COAT COAL TAR ENAMEL TO MINIMUM 3/32" THICKNESS. APPLICATION TEMP. TO BE BETWEEN 450°-475° F.
 - ALLOW COATING TO HARDEN AND INSPECT ELECTRICALLY FOR COATING FAULTS.
 - SPIRAL OR CIGARETTE WRAP WITH COAL TAR ENAMEL IMPREGNATED GLASS FIBER. FLASH WITH TORCH ON UNDERSIDE WHEN APPLYING. PULL WRAP TIGHT TO UNDERLYING COATING.
 - FLASH ENTIRE EXTERNAL SURFACE WITH TORCH AFTER COMPLETION OF TAPE APPLICATION. USE MINIMUM HEAT TO OBTAIN BOND BETWEEN COATING AND WRAP.

DETAIL A
FIELD COATING OF IRREGULARS (TYPICAL)

NOTE: SIMILAR BOND CABLE SHALL BE INSTALLED BETWEEN ACCESS RISER AND TEE SECTION ON OFFSHORE MANHOLES.

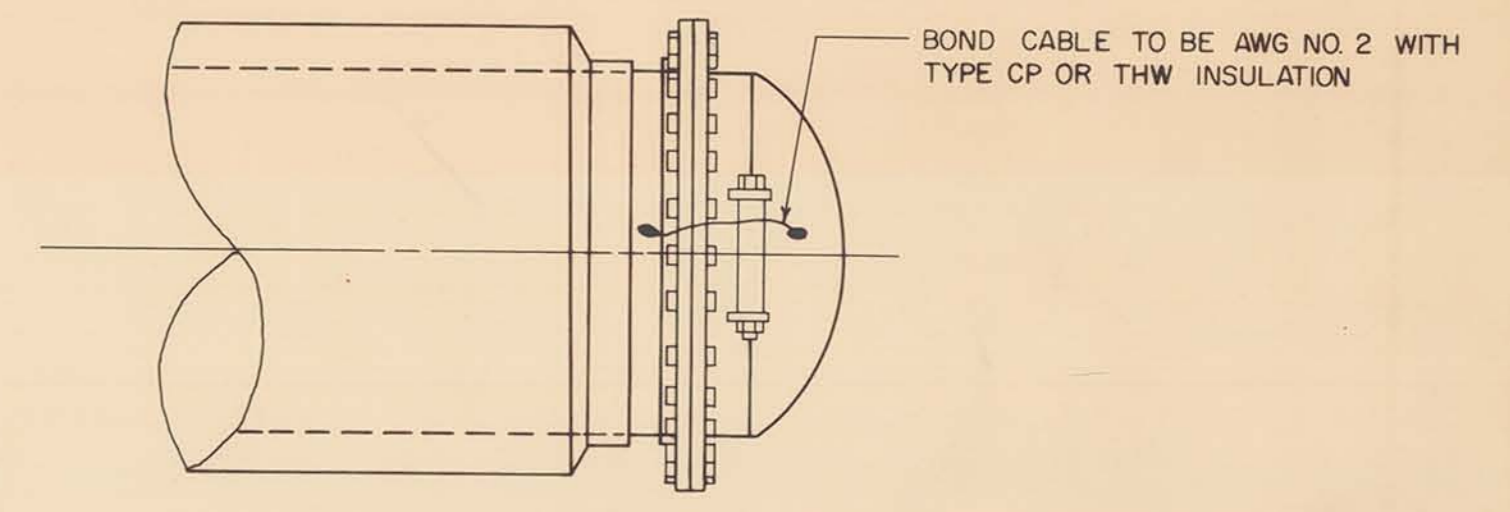

DETAIL B
TYPICAL BONDING OF ACCESS HATCH

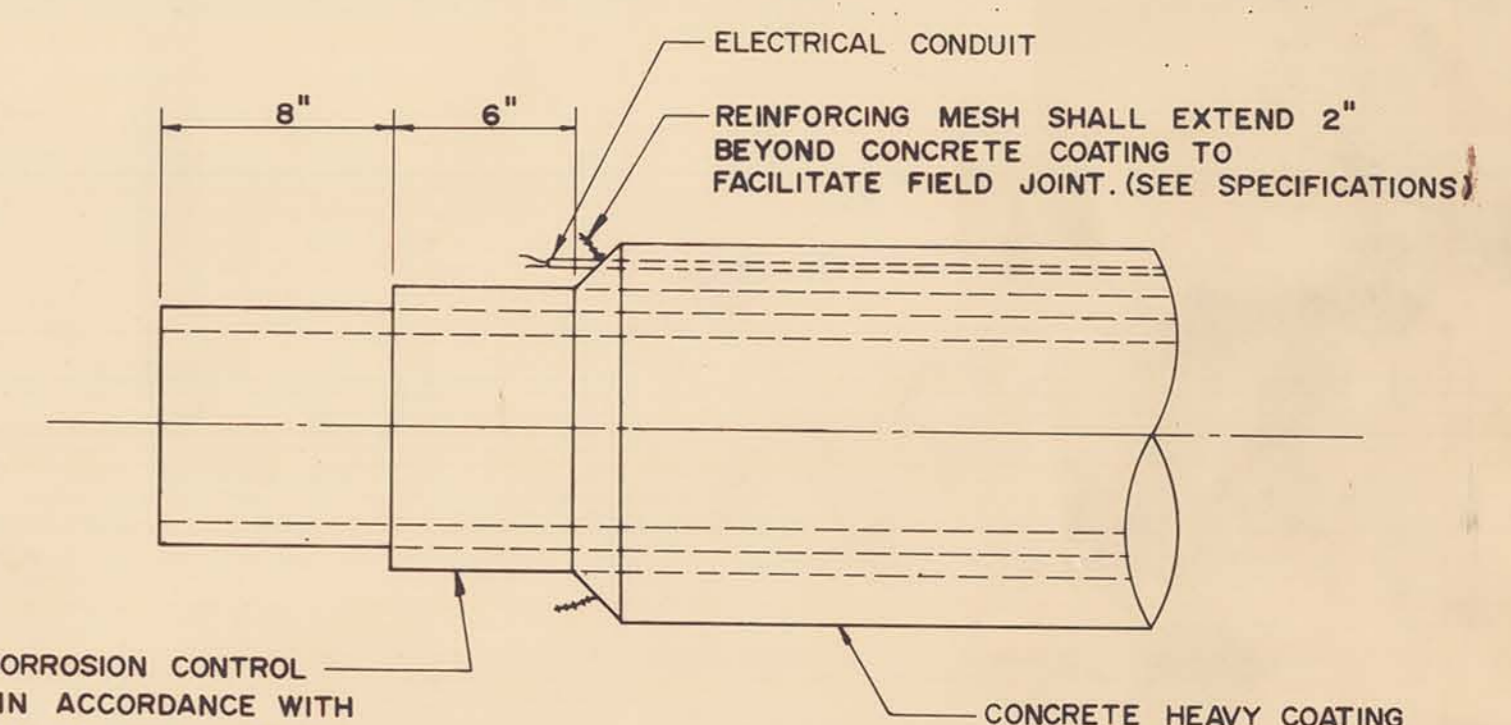

COAL TAR ENAMEL CORROSION CONTROL COATING SHALL BE IN ACCORDANCE WITH NATIONAL ASSOCIATION OF PIPE COATING APPLICATORS SPECIFICATION TGFS-3

DETAIL C
FIELD JOINT

AS BUILT
CORROSION CONTROL
OCEAN OUTFALL
SOUTH COASTAL
REGIONAL WASTEWATER FACILITIES
SUSSEX COUNTY, DELAWARE

DRAWING PREPARED BY
John Wagner
A. V. SMITH ENGINEERING COMPANY
HARBERTH PENNA.

REVISIONS	CHECKED BY DATE	EDWARD H. RICHARDSON ASSOCIATES, INC. CONSULTING ENGINEERS NEWARK, DELAWARE
		APPROVED BY: <i>John Wagner</i>
THIS DRAWING AND THE DESIGN FEATURES OR CONSTRUCTION DISCLOSED ARE PROPRIETARY TO EDWARD H. RICHARDSON ASSOCIATES AND SHALL NOT BE REPRODUCED, ALTERED OR COPIED WITHOUT WRITTEN PERMISSION. SHALL NOT BE USED IN ANY MANNER DETRIMENTAL TO ITS INTEREST AND SHALL BE RETURNED UPON REQUEST.		
SCALE: NONE	DRAWN BY: W.F.E.	
DESIGNED BY: V.J.G.	CHECKED BY: W.W.S.	
DATE: 25-FEB-76	COMM. 834-056-18	FILE NO. F-011 SHEET NO. 11 OF 11

THIS DRAWING DOES NOT INCLUDE NECESSARY COMPONENTS FOR CONSTRUCTION SAFETY
ALL CONSTRUCTION MUST BE DONE IN COMPLIANCE WITH THE OCCUPATIONAL SAFETY AND HEALTH ACT OF 1970 AND ALL RULES AND REGULATIONS THERETO APPURTENANT.

South Coastal RWF & Rehoboth Beach WTF Upgrade

10/25/2024

Vendor/Contract	Description	Contract Value
Michael F. Ronca & Sons, Inc. thru CO 35	SCRWF/RBWWTP General Construction	46,281,901.33
BW Electric Inc. thru. CO 28	SCRWF/RBWWTP Electrical Construction	22,557,177.44
BW Electric Inc. CO #3	DP&L Service Entrance Modification Conduit System	235,637.33
BW P.O.	Soil Screening @ Rehoboth Plant	4,504.50
GHD	Amd 11 - SCRWF Expansion to 10mgd - Planning & Concept	241,938.68
	Amd 12 - SCRWF Expansion Construction Docs	2,240,280.73
	Amd 13 - Value Engineering	95,080.15
	Amd 14 - Rehoboth WTP Capital Improvement Program Upgrade Phase 2/Joint Project with SCRWF Expansion	398,410.63
	Amd 16 - Ocean Outfall Discharge Modeling & Wetlands Delineation for SCRWF and Add'l Design Services for Rehoboth WTP Capital Improvement Program	181,089.72
	Amd 18 - RBWTP CIP Upgrade Phase 2 - Add'l Design	172,153.01
	Amd 19 - SCRWF Upgrade 3 Add'l Design	108,073.71
	Amd 20 - SCRWF Upgrade 3/RBWTP Upgrade Phase 2 Construction Engineering	6,589,558.49
Core & Main	Influent FM Consolidation Materials	339,944.59
Core & Main	Effluent FM Pipeline Materials	227,603.39
Delmarva Power	Improve service entrances for both projects	175,000.00
G&L	FM Consolidation & Influent Consolidation Phase II	973,229.04
G&L Work- Effluent Relocation		316,635.20
G&L Work - RB Treatment Plant	Parking Lot Repavement	
Kershner Environmental Technologies	Belt Press	295,000.00
Melvin Joseph	Material Screening	80,000.00
DSWA	Loading, Hauling & Disposal of Debris	33,000.00
	Hauling of Rehoboth Oxidation Ditch Remnants	39,663.15
Totals		81,585,881.09

ENGINEERING DEPARTMENT

MIKE HARMER, P.E.
SUSSEX COUNTY ENGINEER

(302) 855-7370 T

(302) 854-5391 F

mike.harmer@sussexcountype.gov



Sussex County

DELAWARE
sussexcountype.gov

Memorandum

TO: Sussex County Council
The Honorable Michael H. Vincent, President
The Honorable John L. Rieley, Vice President
The Honorable Cynthia C. Green
The Honorable Douglas B. Hudson
The Honorable Mark G. Schaeffer

FROM: Hans Medlarz, P.E., Retired County Engineer

RE: *Approval of Revised Wastewater Service Agreement
between the City of Seaford and the Unified Sanitary Sewer District*

DATE: October 29, 2024

In February 2017, the Commissioners of Bridgeville and Greenwood requested investigation of an alternate County Sewer District based scenario. The Engineering Department developed an alternate scenario for a Western Sussex County Sewer District connecting to the City of Seaford. Based on a more favorable cost scenario, both municipal Councils requested formation of a county sewer district pursuant to Title 9 Del. Code § 6501. On August 22, 2017, and County Council established the Western Sussex Area of the Unified Sewer District.

The City of Seaford provides wastewater services for the Blades and Western Sussex Areas of the Unified Sussex County Sewer District under a wastewater service agreement executed by both Councils in May of 2018. On September 17, 2019, Council approved Addendum No. 1 to the Wastewater Service Agreement to jointly fund I&I investigations and fiber communication extensions on a flow-based cost split as well as the colocation arrangements at the City's public works complex.

The City's Code referenced in the 2018 Wastewater Service Agreement was amended by City Council requiring a reference modification of Section 9, covering the type and collection of sewer impact fees. The city split the fees, and both would apply to any connections made in the Western Sussex Area of the Unified Sewer District. Council approved Addendum No. 2 on June 4, 2024.

The City is embarking on a major treatment plant expansion incurring significant capital costs in the process. For proper planning, the City suggested to introduce a County "capacity reserve" of 40% into the Agreement. It is subject to a ten (10) year review and possible adjustment. In addition, the city is seeking an expedited reimbursement process for emergency projects on a flow basis. Both these issues were incorporated in the revised agreement presented today. Therefore, the Engineering Department is requesting approval of the Revised Wastewater Service Agreement between the City of Seaford and the Unified Sanitary Sewer District.



Wastewater Service Agreement
between
City of Seaford & Sussex County Unified Sanitary Sewer District

The Agreement for Services is made and entered this . day of _____, 2024 (“Effective Date”), by and between THE CITY OF SEAFORD, a municipality of the State of Delaware (hereinafter referred to as “CITY”), and SUSSEX COUNTY, a political subdivision of the State of Delaware (hereinafter referred to as “COUNTY”).

WHEREAS, the CITY owns and operates a wastewater treatment plant located on Nanticoke Avenue in Seaford, Delaware to be referred to as the “WWTP;” and

WHEREAS, on May 15, 2018 the parties entered into a Wastewater Service Agreement (“Agreement”) regarding conveyance of sanitary sewage emanating from the collection systems of the Western Sussex and Blades Areas of the Unified Sanitary Sewer District to the City’s sanitary sewer system for treatment and disposal; and

WHEREAS, on September 17, 2019, the parties signed Addendum No. 1 to the Agreement; and

WHEREAS, on June 18, 2024, the parties signed Addendum No.2 to the Agreement. and

WHEREAS, the County proposes to convey sanitary sewage emanating from the Western Sussex and Blades Areas of the Unified Sanitary Sewer District to the CITY’s sanitary sewer system for treatment at the WWTP; and

WHEREAS the CITY wishes to grant the COUNTY the privilege of discharging wastewater from the Unified Sanitary Sewer District of Sussex County into the wastewater facilities of the CITY; and

Wastewater Service Agreement
between
City of Seaford & Sussex County Unified Sanitary Sewer District

WHEREAS, the parties hereto desire to terminate all prior agreements and addenda and to substitute in-lieu thereof, this Agreement between them relating to all areas of the Unified Sanitary Sewer District discharging to the CITY's WWTP.

NOW, THEREFORE, in consideration of the mutual covenants hereinafter expressed, the parties hereto agree as follows:

1. For the purposes of the Agreement, it is mutually agreed by the parties hereto that the following definitions shall apply unless the context indicates to the contrary:

- (a) Wastewater shall be defined as liquid waste delivered by the COUNTY to the CITY with characteristics generally recognized as those associated with normal domestic sewage conforming fully with the CITY's sewer use ordinance (SUO) and the requirements of "Wastewater Quality Criteria" attached hereto as Exhibit A.
- (b) Treatment shall be deemed to include those processes as are necessary to provide an effluent from the WWTP to fully comply with the National Pollutant Discharge Elimination System (NPDES) permit(s) issued by the State of Delaware.
- (c) Average Daily Flow (ADF) of the combined District areas shall be defined as the total monthly flow measured at the COUNTY'S pump stations divided by the number of days in said month.
- (d) District shall mean the Unified Sanitary Sewer District of Sussex County as shown on Exhibit B1 and B2, except that the COUNTY may enlarge or revise the boundaries of the District in accordance with the provisions of Chapter 65, Title 9, Delaware Code Annotated, without the necessity

Wastewater Service Agreement
between
City of Seaford & Sussex County Unified Sanitary Sewer District

for further modification of the description contained herein. The COUNTY shall coordinate expansion or revision of the District boundaries with the CITY in accordance with the certified comprehensive land use plans of the CITY and the COUNTY.

- (e) Moratorium shall mean an authorized period of delay in the contribution of flows to the CITY's WWTP.
 - (f) Equivalent Dwelling Unit (EDU) shall mean an arbitrary term used to express the volume based, load-producing effects on the sewer system caused by one average sized residential dwelling contributing 250 gallons per day of wastewater.
 - (g) Shared Transmission System shall mean collector gravity pipelines and pump station(s) with pressurized pipelines owned by CITY and used to convey both COUNTY and CITY wastewater to the WWTP.
2. CITY agrees to accept for conveyance and treatment the wastewater of COUNTY pursuant to the terms of this Agreement; provided however, that CITY reserves the right to refuse to accept any wastewater which does not comply with the limits of Exhibit A attached hereto.
3. COUNTY agrees to the Interjurisdictional Agreement for Industrial Pretreatment explained in Exhibit D attached hereto. The COUNTY will add and adopt the following language into their Sewer Use Ordinance (SOU). *"Users who discharge into the SCUSSD shall be subject to the rules and regulations pursuant to the City of Seaford SUO Chapter 6, Title 7, Chapter 60, Section 6033 of the DE Code and 40 CFR Part 403 of the Federal Code."* This language will give the CITY legal

Wastewater Service Agreement
between
City of Seaford & Sussex County Unified Sanitary Sewer District

authority to enforce the CITY'S Pretreatment Program as described in Exhibit D in the SCUSSD.

4. It is mutually agreed by the parties hereto that this Agreement shall become effective upon its execution and delivery by the parties hereto and shall remain in effect for twenty (20) years, unless sooner terminated by mutual agreement of both parties hereto.
5. COUNTY will operate and maintain District pump stations and transmission mains, to the connection points with the CITY's manhole on the north side of the Nanticoke River, on Nanticoke Avenue and at the focemain discharge manhole located on the south-east corner of the intersection between US RT-13 and Old Furnace Road, or any other points of connection which may be established in the future by the mutual agreement of both parties.
6. COUNTY will install magnetic flow meters at each pump station, recording wastewater volume delivered by COUNTY to the CITY. All measurements of County's sewage flow, as required by this Agreement, shall be performed under a monitoring program conducted and paid for by the COUNTY. The results of all flow measurements shall be provided to both parties monthly. The metering devices utilized to measure COUNTY's volumes flow shall be calibrated annually by an independent testing agency. The results of the calibrations shall be made available to CITY. If the calibration reveals a discrepancy greater than five percent (5%), the monthly sewer billing for operational costs to the COUNTY shall be adjusted (up or down) in the amount of the discrepancy for a three (3) month period immediately preceding the calibration. No action shall be taken for metering devices within five

Wastewater Service Agreement
between
City of Seaford & Sussex County Unified Sanitary Sewer District

percent (5%) accuracy. Billing or credit adjustments shall be made on the next billing period immediately following the discovery of the metering discrepancy unless the parties agree otherwise.

7. CITY agrees to accept the COUNTY's wastewater flows at the connection points up to the quantity limits set forth in the Agreement and treat COUNTY's wastewater to a degree sufficient to enable the final effluent to comply with the WWTP's NPDES Permit and to dispose of such treated effluent in compliance with said NPDES Permit and any other applicable laws, regulations, or policies.
8. CITY shall reserve ADF treatment capacity for the COUNTY at the WWTP not to exceed forty percent (40%) of the design capacity, with an instantaneous maximum flow of two (2) times the COUNTY's treatment capacity on a gallons per minute basis. This percentage shall apply to the current two (2) MGD WWTP and the future three (3) MGD WWTP once - completed. The reserve treatment capacity may be reevaluated ten (10) years after the effective date of this agreement by request from either the COUNTY or CITY.
9. The COUNTY shall pay CITY's sewer impact fees for new units to be connected on an equivalent dwelling unit basis. Impact fee shall be based upon the City of Seaford Municipal Code Chapter 11, Article 7. CITY will annually provide to COUNTY the impact fee rate amount applicable by June 1, preceding the upcoming fiscal year beginning July 1. Impact fees shall be payable to the CITY the first day of each quarter based on COUNTY sewer permit issuance, except for any of the legacy obligations assumed by the COUNTY with regards to Passwaters Farm, LLC and Bridgeville Park Center, LLC which stand at approximately 350 EDUs at

Wastewater Service Agreement
between
City of Seaford & Sussex County Unified Sanitary Sewer District

execution of this Agreement. The EDU associated with the legacy issues shall be tracked separately by the COUNTY and accounted for annually until exhausted.

10. COUNTY agrees to pay CITY, *monthly*, its share of operational expenses related to the shared transmission and treatment facilities.

(a) Such share shall be determined by dividing the actual metered monthly flow discharged from COUNTY's District to the CITY's system by the total gallons metered monthly as discharged from the WWTP and multiplying that factor by the total operating expenses of the shared transmission and treatment facilities for that month.

(b) Operational expenses shall include actual costs and expenses relating to operations, capital, repair, and maintenance, including the solar power facility at 8000 Herring Run Road, labor, materials and supplies that relate to the CITYs' operation of the shared transmission and treatment facilities.

(c) The operational costs shall also include a ten (10) percent administrative charge calculated using the total COUNTY's operations and maintenance charges for the billing period. In addition, the generated kWh electrical production of the solar power facility and shall be credited against the total electrical consumption of the WWTP.

(d) COUNTY agrees that a treatment surcharge may be added to the monthly charges for wastewater which does not comply with the Wastewater Criteria described in Exhibit A.

(e) COUNTY agrees in the event wastewater discharged from the COUNTY's District into the treatment plant exceeds or violates the limits indicated in

Wastewater Service Agreement
between
City of Seaford & Sussex County Unified Sanitary Sewer District

Exhibit A, and/or which will require special handling or treatment, the total costs for providing such special handling or treatment shall be determined by the CITY and shall be borne solely by the COUNTY.

11. Debt service associated with the 2016 Delaware Water Pollution Control Revolving Fund Loan shall be paid for by the CITY with proceeds from the sale of SREC's. Should this revenue not be adequate to meet the required debt service needs of the facility the CITY shall assess the COUNTY a proportionate share of the remaining debt service costs.
12. COUNTY agrees to pay their corresponding percentage of the semi-annual debt service for the capacity reservation associated with the shared transmission and treatment facilities. In July of each year, CITY shall send an invoice to the COUNTY for debt service costs for funds obtained through any legally issued Bond, loan or other debt instrument. The COUNTY shall pay the undisputed amounts of any invoice received from CITY for such costs within thirty (30) days of receipt thereof.
13. The CITY shall address any emergencies or unforeseen costs with respect to the CITY's WWTP. Any expenditure to address such emergencies shall be reported to the COUNTY within thirty (30) days after the cost is determined. The COUNTY shall submit payment within two weeks to the CITY for its percentage per this agreement from an estimate provided by the CITY. The CITY must submit a copy of the paid invoice after the work is completed to close out each emergency expense. Any overpayment or underpayment by the COUNTY shall be rectified by the parties within 30 days of completed emergency projected.
14. If COUNTY decides, during the term of this Agreement, to seek alternative options

Wastewater Service Agreement
between
City of Seaford & Sussex County Unified Sanitary Sewer District

for treating the COUNTY's wastewater and eliminates flows to the CITY, the CITY can regain full use of all capacity given up by the COUNTY without compensation. In the event the COUNTY wishes to remove all or a portion of its flows purchased via impact fees, after execution of this Agreement, the CITY may regain that portion of the capacity given up by the COUNTY by reimbursing the COUNTY of up to seventy-five (75) percent of the associated impact fees paid for said capacity based on straight line depreciation of the financed assets.

15. If the CITY deems it necessary to impose a moratorium upon additional flows to the WWTP, the COUNTY will also be required to place a moratorium on their flows from the COUNTY and halt sewer permit issuance. The lifting of any moratorium implemented by the CITY will also lift the moratorium for the COUNTY.
16. Each party hereto, by a duly authorized representative, shall have the right at any time during business hours to inspect the books and records of the other party to ascertain the correctness of any figures used in computing the liability of any party to any other party. CITY agrees to provide COUNTY an annual budget and audit report for the CITY's shared transmission facilities, the WWTP and the biosolids operations.
17. During the term of this Agreement, the COUNTY shall sample the district pumping stations (Blades PS45 and Bridgeville) according to the Schedule detailed below.

Pollutant	Sample Type	Sample Schedule
BOD	24hr flow proportioned composite	Blades: Once / Month Bridgeville: Once / Month
TSS	24hr flow proportioned composite	Blades: Once / Month Bridgeville: Once / Month
TKN	24hr flow proportioned composite	Blades: Once / Month Bridgeville: Once / Month

Wastewater Service Agreement
between
City of Seaford & Sussex County Unified Sanitary Sewer District

Ammonia as N	24hr flow proportioned composite	Blades: Once / Month Bridgeville: Once / Month
Nitrate+Nitrite as N	24hr flow proportioned composite	Blades: Once / Month Bridgeville: Once / Month
Total Phosphorus	24hr flow proportioned composite	Blades: Once / Month Bridgeville: Once / Month
Copper, Zinc	24hr flow proportioned composite	Blades: Once / Month Bridgeville: Once / Month
pH	Grab	Blades: Once / Month Bridgeville: Once / Month
Seaford Local Limits Scan	24hr flow proportioned composite	Blades: Once / Year Bridgeville: Once / 3 Months

The COUNTY shall sample for other constituents at the request of the CITY, if just cause is given. The COUNTY shall compile and report all results of these tests each month along with the flow report data. This report shall be submitted to the CITY no later than the 10th day of the subsequent month for use in calculating the monthly billing cycle. The results of any monitoring performed beyond the requirements of this agreement shall also be reported. The CITY shall be granted access to the COUNTY's collection system and/or pumping stations for its own monitoring.

18. CITY will notify COUNTY if chronic permit compliance problems are experienced at CITY's Wastewater Treatment Facilities including biosolids operations. If such problems are experienced due to wastewater conveyed by the COUNTY, then COUNTY will take immediate steps to remedy any situation, which causes such problems. If COUNTY is unable to remedy such situations, COUNTY may be required to install a pretreatment system to reduce wastewater constituents exceeding the "Wastewater Quality Criteria" attached hereto as Exhibit A.

19. It is mutually agreed by the parties hereto that to the extent permitted by law, each of them shall indemnify and hold harmless the other party, including its elected and

Wastewater Service Agreement
between
City of Seaford & Sussex County Unified Sanitary Sewer District

appointed officials, servants, agents and/or employees against all losses, costs or damages on account of any bodily injury or property damage occurring in the performance of this Agreement due to the negligence of the indemnifying party, its respective servants, agents, and/or employees, or resulting from the failure of the WWTP, and facilities leading thereto, to function properly because of such negligence. To the fullest extent permitted by law, CITY waives any right of recovery from COUNTY and its elected and appointed officials, servants, agents, and/or employees for any loss of or damage to the WWTP (including any consequential loss that may result), regardless of the cause of origin, including the negligence of the COUNTY and, its elected and appointed officials, servants, agents and/or employees, to the extent covered by required insurance. CITY shall advise its property insurer(s) of the foregoing and such waiver shall be permitted under any property insurance policies maintained by CITY.

20. The CITY agrees to secure and maintain, at its own expense, all risk (special form) property and extra expense insurance, equipment breakdown insurance including extra expense insurance on the WWTP including biosolids and commercial general liability insurance with insurers authorized and qualified to do business under the laws of the State of Delaware against loss or damage, fire and other risk and casualty. The property insurance should provide for a limit of liability not less than 100 percent of the insurable replacement cost of the Treatment Plant and/or Compost area and the extra expense insurance coverages should have a limit of not less than \$500,000 each occurrence. The commercial general liability insurance should have a limit of not less than \$1,000,000 each occurrence with

Wastewater Service Agreement
between
City of Seaford & Sussex County Unified Sanitary Sewer District

General Aggregate and Products Completed Aggregate limits of not less than \$2,000,000 each. CITY agrees to add COUNTY, its respective elected and appointed officials, servants, agents, and/or employees as additional insured on CITY's extra expense and commercial general liability insurance. Immediately after any loss or damage to the treatment plant, or any part thereof, the CITY will commence and duly prosecute the repair, replacement or reconstruction or the damages or destroyed portion of the treatment plant, compost area, and wastewater conveyance system according to the plans and specifications therefore prepared by its consulting engineers. The COUNTY shall secure and maintain, at its own expense, commercial general liability insurance with limits equal to those required of CITY and the CITY shall be listed as an additional insured on all pertinent County policies.

21. Analysis of Wet-weather Impacts. In recognition of CITY's offer to correct any wet-weather impacts outside of the shared transmission and conveyance facilities at the CITY's expense the COUNTY previously agreed to contribute to the evaluation costs on a flow proportional basis not to exceed \$20,000.00.
22. Extension of Fiber Communications. In recognition of CITY's offer to relocate the connection point, the COUNTY previously agreed to contribute to the labor and material cost of extending fiber optic cable to pump station no. 16 on a flow proportional basis not to exceed \$80,000.00.
23. Maintenance Cooperation. Both parties previously agreed on the benefit of collocating a COUNTY maintenance facility at an existing CITY facility. The COUNTY maintenance facility, which was part of the State funded project, will

Wastewater Service Agreement
between
City of Seaford & Sussex County Unified Sanitary Sewer District

primarily serve the Unified Sanitary Sewer District's assets, but can be made available to assist the CITY's forces as needed.

24. The following positions shall be notified by phone within 24 hours and in writing within 5 days in relation to any violation of this Agreement:

For the CITY,

City Manager	(302) 629-9173	414 High Street	Seaford, DE 19973
Public Works Director	(302) 629-8307	414 High Street	Seaford, DE 19973
Operations Coordinator	(302) 629-8340	403 Nanticoke Ave.	Seaford, DE 19973
Non-business hours: Seaford Police Dept.	(302) 629-6644	300 Virginia Avenue	Seaford, DE 19973

For the COUNTY,

County Administrator	302-855-7742
County Engineer	302-855-7370
Director of Environmental Services	302-855-7730
Non-business hours	302-855-7803

It is mutually agreed by the parties hereto, that the terms of this Agreement shall be binding not only upon the parties hereto, but also upon their respective successors and assigns.

Wastewater Service Agreement
between
City of Seaford & Sussex County Unified Sanitary Sewer District

IN WITNESS WHEREOF, the parties hereto have caused this Agreement to be executed by their proper corporate officers and their respective corporate seals to be hereto affixed, the day and year first above written.

CITY of SEAFORD

By: _____
Matt MacCoy, Mayor
City of Seaford

Attest: _____
Secretary

SUSSEX COUNTY

By: _____
Michael H. Vincent, President,
Sussex County Council

Attest: _____
Clerk, Sussex County Council

Wastewater Service Agreement
between
City of Seaford & Sussex County Unified Sanitary Sewer District

EXHIBIT A

WASTEWATER QUALITY CRITERIA

All wastewater delivered to the CITY by the COUNTY shall be subject to the following standards:

1. No storm water, surface water, ground water, cooling water or other unpolluted waters.
2. The average concentration of BOD, TSS, TKN, NH₃-N and TP discharged to the City's sewer system shall be in accordance with "domestic wastewater" concentrations as defined in the City's Sewer Use Ordinance Section 11.1.4. A surcharge may be assessed and charged to the COUNTY when these parameters exceed normal domestic wastewater strength according to Section 11.7.7 of the City's Sewer Use Ordinance.
3. pH shall range between 6 s.u. and 9 s.u.
4. Average temperature shall range between 50 degrees F. and 70 degrees F., with maximum instantaneous temperature never to exceed 104 degrees F.
5. Fog, oil and grease fats, and wax shall not exceed 30 parts per million average and 100 parts per million peak.
6. The following substances are prohibited:
 - a. Hauled waste – including septage, portable toilet waste, and industrial waste which are not regulated by the City of Seaford's Pretreatment Program.
 - b. Gasoline or any other flammable or explosive liquid, solid or gas - none.
 - c. Malodorous or toxic gases or vapors - none.
 - d. Garbage - only portions which pass through pump station.
 - e. Solid, semi-solid, or viscous substances capable of obstructing pipelines or interfering with treatment processes - none.
 - f. Pickling wastes or plating solutions - none.

Wastewater Service Agreement
between
City of Seaford & Sussex County Unified Sanitary Sewer District

- g. Minerals - only to the extent tolerable to the normal treatment process.
 - h. Radioactive materials - none
 - i. Toxic substances shall not exceed the Maximum Allowable Headworks Concentrations (MAHCs) calculated by the CITY. The concentrations shall be determined based on the total wastewater flow entering the POTW and the Maximum Allowable Headworks Loading (MAHL) established in most recently approved local limits evaluation. The CITY shall provide timely updates or revisions to these concentrations as they are adopted. These concentrations are considered "daily maximum" concentrations based on a 24-hr composite sample.
 - j. Any other solid, liquid or gaseous substances which has an adverse effect on transmission, treatment, or disposal of wastewater or is in violation of State or Federal Statues or regulations - none.
7. "Average," as used hereinbefore, shall be defined as the monthly mean value, as determined by totaling the individual sampling results and dividing that value by the number of samples taken during the month in question.
8. "Peak", as used hereinbefore, shall be defined as a parameter value which has duration of 15 minutes or longer on any given day, as determined by sampling and testing.

Casey Hall

From: notifications=d3forms.com@mg.d3forms.com on behalf of Sussex County DE <notifications@d3forms.com>
Sent: Thursday, October 3, 2024 7:39 AM
To: Casey Hall
Subject: Form submission from: Council Grant Form

CAUTION: This email originated from outside of the organization. Do not click links, open attachments, or reply unless you recognize the sender and know the content is safe. Contact the IT Helpdesk if you need assistance.

Council Grant Form

Legal Name of Agency/Organization Shaffer Foundation LLC under the Greater Lewes Foundation

Project Name 4th Annual Rally For Our First Responders

Federal Tax ID 51-0400365

Non-Profit Yes

Does your organization or its parent organization have a religious affiliation? (If yes, fill out Section 3B.) No

Organization's Mission Have the Community Rally for Our First Responders to give thanks and give back to those who keep us safe every day.

Address PO Box 110

City Lewes

State DE

Zip Code 19958

Contact Person Kyle Shaffer

Contact Title	Founder and President of the Shaffer Family Foundation
Contact Phone Number	302-233-2076
Contact Email Address	Kyle@shafferfoundation.com
Total Funding Request	3,000
Has your organization received other grant funds from Sussex County Government in the last year?	No
If YES, how much was received in the last 12 months?	N/A
Are you seeking other sources of funding other than Sussex County Council?	Yes
If YES, approximately what percentage of the project's funding does the Council grant represent?	.03
Program Category (choose all that apply)	Health and Human Services
Primary Beneficiary Category	Other

Beneficiary Category Other	First Responders
Approximately the total number of Sussex County Beneficiaries served, or expected to be served, annually by this program	12
Scope	To Raise money for the 12 beneficiaries in Sussex County - Ex: 5 Fire Departments - To help raise money for equipment and training. Georgetown EMS,
Please enter the current support your organization receives for this project (not entire organization revenue if not applicable to request)	0.00
Description	Stage/Sound/Bands
Amount	8,000.00
Description	Event Insurance
Amount	1,000.00
Description	Advertising, Cape Gazette online
Amount	0.00
Description	Signs, Banners
Amount	0.00
Description	Hudson Fields Rental

Amount	500.00
Description	Tickets, 50/50 tickets, bracelets, square readers, flyers
Amount	4,000.00
Description	Miscellaneous
Amount	2,000.00
TOTAL EXPENDITURES	15,500.00
TOTAL DEFICIT FOR PROJECT OR ORGANIZATION	-15,500.00
Name of Organization	Shaffer Foundaion, LLC
Applicant/Authorized Official	Kyle Shaffer
Date	10/03/2024
Affidavit Acknowledgement	Yes

If you feel this is not a valid submission please log into D3Forms to update this submissions status.
Please feel free to email clientservices@d3corp.com with any questions.

Casey Hall

From: notifications=d3forms.com@mg.d3forms.com on behalf of Sussex County DE <notifications@d3forms.com>
Sent: Sunday, October 6, 2024 10:40 AM
To: Casey Hall
Subject: Form submission from: Council Grant Form

CAUTION: This email originated from outside of the organization. Do not click links, open attachments, or reply unless you recognize the sender and know the content is safe. Contact the IT Helpdesk if you need assistance.

Council Grant Form

Legal Name of Agency/Organization Southern Delaware Orchestra, d/b/a SODELO

Project Name SODELO Winter 2024 Concerts

Federal Tax ID 882738909

Non-Profit Yes

Does your organization or its parent organization have a religious affiliation? (If yes, fill out Section 3B.) No

Organization's Mission The Southern Delaware Orchestra (SODELO) is a community orchestra dedicated to fostering musical excellence, diversity, inclusion, collaboration, and community engagement in Southern Delaware. Our mission is to provide a welcoming environment where musicians can learn, play, and perform a wide range of orchestral music for the southern Delaware community; provide opportunities to students in musical arts; collaborate with other arts and music groups; and inspire the next generation of musicians. Our concerts celebrate community, culture, and the enduring power of music, and

	we work to ensure everyone feels accepted and included in our musical journey.
Address	P.O. Box 83
City	Nassau
State	Delaware
Zip Code	19969
Contact Person	Charles Bachman
Contact Title	Board Member & Grant Committee Chair
Contact Phone Number	7036261676
Contact Email Address	cab_phd@outlook.com
Total Funding Request	\$1750
Has your organization received other grant funds from Sussex County Government in the last year?	No
If YES, how much was received in the last 12 months?	N/A
Are you seeking other sources of funding other than Sussex County Council?	Yes

If YES, approximately what percentage of the project's funding does the Council grant represent?	6.5
Program Category (choose all that apply)	Cultural Health and Human Services
Primary Beneficiary Category	Elderly Persons (62 +)
Approximately the total number of Sussex County Beneficiaries served, or expected to be served, annually by this program	1000
Scope	<p>Founded in May 2022 by Steve Greifer, Eva DelGallo, and Dr. James A. Anderson, SODELO began as a community of string musicians. Our first rehearsal on May 3, 2022, led to the Southern Delaware Orchestra's inaugural concert on July 16, 2022 at Bethel United Methodist Church in Lewes, drawing 250 attendees.</p> <p>SODELO grew rapidly, performing three more concerts in 2022-2023 with an increasing attendance, reaching over 450 at venues like the Rehoboth Beach Convention Center and Epworth United Methodist Church in Lewes, DE. Our repertoire spanned popular classical pieces to the Great American Songbook. In 2023, AARP invited SODELO to support the Andrus Award celebration with a free Broadway recital at the Delaware Grand Opera House in Wilmington. Featuring Broadway performer Aidan Briggs, SODELO expanded its ensemble with wind and percussion musicians. The November performance attracted nearly 800 attendees, followed by a holiday concert in December drawing over 400 attendees..</p>

Because of its growing and enthusiastic audience base, combined with many inquiries from local wind, brass, and percussion musicians seeking opportunities to perform, SODELO aimed to become a full orchestra. Auditions in May 2024 led to the formation of a 71- member symphony orchestra, debuting with "Out of This World" concerts in August 2024 at Global Mariner's Global Methodist Church and Cape Henlopen High School, reaching 1,000 attendees across both events.

SODELO addresses Sussex County's cultural needs by offering accessible orchestral music concerts and providing musicians of all ages, backgrounds, and skill levels with opportunities to perform locally within Sussex County. The organization aims to build awareness and foster appreciation of orchestral music through live performances and community engagement. The organization operates on an annual budget of approximately \$92,000, covering expenses such as venue rentals, music purchases, personnel expenses, marketing, and insurance. The organization relies heavily on volunteers, with over 40 individuals managing various aspects of operations, including grant writing, financial management, donor relations, website and social media maintenance, marketing, and concert assistance.

This application requests \$2,500 to support SODELO's upcoming 2024 Holiday Concert series. The orchestra has planned two performances:

- December 14, 2024, at Sussex Academy in Georgetown, DE (expected attendance: 250)
- December 15, 2024, at Cape Henlopen High School in Lewes, DE (expected attendance: 750)

The 2024 Holiday Concert series will feature a diverse and engaging program of holiday classics and orchestral masterpieces, providing the community with access to exceptional live music during the festive season. Our 2024 Holiday Concert series will showcase a carefully curated program offers a blend of traditional favorites and

contemporary arrangements, showcasing the full range of our orchestra's capabilities. From the intimate string performances of "Silent Night" and "Greensleeves" to the grand orchestral works like Rimsky-Korsakov's "Christmas Eve Suite", the "Festive Sounds of Hanukah", and the "Polar Express Concert Suite," our audience will experience the rich diversity of holiday music.

The 2024 Holiday Concert goals are:

- Present two high-quality holiday concerts featuring a diverse and engaging program
- Continue to extend our geographic reach and impact with our first concert in Georgetown, DE
- Increase community access to live orchestral music, showcasing both traditional and holiday compositions
- Engage and inspire diverse audiences, including youth and families, through a varied musical experience
- Strengthen SODELO's presence and impact in Sussex County by demonstrating the full range of orchestral capabilities.

Out expected outcomes are:

- Reach a combined audience of 1,000 attendees across both performances
- Enhance the cultural offerings in Sussex County during the holiday season with a diverse and high-quality musical program
- Provide performance opportunities for local musicians across a wide range of orchestral instruments
- Increase awareness and appreciation for orchestral music in the community, particularly for holiday-themed compositions
- Showcase the versatility of SODELO through performances ranging from small ensemble pieces to full orchestral works.

SODELO's Winter 2024 Concerts will be measured by:

- Ticket sales and attendance figures (aiming for 250 attendees in Georgetown and 750 in Lewes)

- Audience surveys to gather feedback on the concert experience and the variety of the musical program
- Social media engagement and press coverage, particularly noting audience response to specific pieces in the program
- Financial analysis comparing projected vs. actual expenses
- Musician feedback on the rehearsal and performance experience with this diverse program

Religious Components	Not applicable
Please enter the current support your organization receives for this project (not entire organization revenue if not applicable to request)	24,400.00
Description	Music Director, Concertmaster & Soloist fees
Amount	14,200.00
Description	Musician travel reimbursements
Amount	2,700.00
Description	Venue rental: Sussex Academy, Georgetown
Amount	1,000.00
Description	Venue rental: Cape Henlopen HS, Lewes
Amount	2,300.00
Description	Music Rental
Amount	500.00
Description	Advertising, printing & promotion

Amount	4,250.00
Description	Rehearsal space rental
Amount	1,000.00
Description	Ticket processing fees
Amount	1,000.00
TOTAL EXPENDITURES	26,950.00
TOTAL DEFICIT FOR PROJECT OR ORGANIZATION	-2,550.00
Name of Organization	SODELO
Applicant/Authorized Official	Charles A Bachman
Date	10/06/2024
Affidavit Acknowledgement	Yes

If you feel this is not a valid submission please log into D3Forms to update this submissions status.
Please feel free to email clientservices@d3corp.com with any questions.

Casey Hall

From: notifications=d3forms.com@mg.d3forms.com on behalf of Sussex County DE <notifications@d3forms.com>
Sent: Tuesday, October 8, 2024 11:41 AM
To: Casey Hall
Subject: Form submission from: Council Grant Form

CAUTION: This email originated from outside of the organization. Do not click links, open attachments, or reply unless you recognize the sender and know the content is safe. Contact the IT Helpdesk if you need assistance.

Council Grant Form

Legal Name of Agency/Organization Town of Georgetown

Project Name Mayor's Reception - 2024 Return Day

Federal Tax ID 51-6000120

Non-Profit Yes

Does your organization or its parent organization have a religious affiliation? (If yes, fill out Section 3B.) No

Organization's Mission To say thank you and express appreciation to Federal, State, County, and Local Leaders.

Address 37 The Circle

City Georgetown

State Delaware

Zip Code 19947

Contact Person Kristen Dabrowski

Contact Phone Number	3028567391
Contact Email Address	kdabrowski@georgetowndel.com
Total Funding Request	2,000
Has your organization received other grant funds from Sussex County Government in the last year?	No
If YES, how much was received in the last 12 months?	N/A
Are you seeking other sources of funding other than Sussex County Council?	Yes
If YES, approximately what percentage of the project's funding does the Council grant represent?	28
Program Category (choose all that apply)	Cultural
Primary Beneficiary Category	Other
Beneficiary Category Other	Local Municipality

Approximately the total number of Sussex County Beneficiaries served, or expected to be served, annually by this program	10000
Scope	<p>This request is for Sussex County support for the biannual Mayor's Reception to be held immediately following the Return Day Parade and Ceremony being held on Thursday, November 7, 2024.</p> <p>The Mayor's Reception is an opportunity to say "thank you" and express appreciation to Federal, State, County, and Local leaders.</p>
Please enter the current support your organization receives for this project (not entire organization revenue if not applicable to request)	7,000.00
Description	Food and Beverage
Amount	5,100.00
Description	Venue
Amount	450.00
Description	Entertainment
Amount	1,200.00
Description	Personnel/Other
Amount	250.00

TOTAL EXPENDITURES	7,000.00
TOTAL DEFICIT FOR PROJECT OR ORGANIZATION	0.00
Name of Organization	Town of Georgetown
Applicant/Authorized Official	Kristen Dabrowski
Date	10/08/2024
Affidavit Acknowledgement	Yes

If you feel this is not a valid submission please log into D3Forms to update this submissions status.
Please feel free to email clientservices@d3corp.com with any questions.

Casey Hall

From: notifications=d3forms.com@mg.d3forms.com on behalf of Sussex County DE <notifications@d3forms.com>
Sent: Wednesday, October 9, 2024 1:46 PM
To: Casey Hall
Subject: Form submission from: Council Grant Form

CAUTION: This email originated from outside of the organization. Do not click links, open attachments, or reply unless you recognize the sender and know the content is safe. Contact the IT Helpdesk if you need assistance.

Council Grant Form

Legal Name of Agency/Organization Business Professionals of America, Mariner Middle School Chapter

Project Name "Capture the Moment" - 2024-25 Business Professionals of America

Federal Tax ID 51-6000279.

Non-Profit Yes

Does your organization or its parent organization have a religious affiliation? (If yes, fill out Section 3B.) No

Organization's Mission Business Professionals of America, Mariner Middle School Chapter, is committed to developing and empowering Grade 7-8 student leaders to both discover their passion and change the world. To accomplish this, we aim to provide our members with unmatched opportunities in the areas of learning, professional growth and service.

Address Mariner Middle School

Address 2 16391 Harbeson Road

City	MILFORD
State	Delaware
Zip Code	19963-1050
Contact Person	Daniel Shockley
Contact Title	Advisor / Teacher
Contact Phone Number	3025420811
Contact Email Address	Danielh.shockley@cape.k12.de.us
Total Funding Request	2000
Has your organization received other grant funds from Sussex County Government in the last year?	No
If YES, how much was received in the last 12 months?	N/A
Are you seeking other sources of funding other than Sussex County Council?	No
If YES, approximately what percentage of the project's funding does the Council grant represent?	N/A

Program Category (choose all that apply)	Educational
Primary Beneficiary Category	Youth
Approximately the total number of Sussex County Beneficiaries served, or expected to be served, annually by this program	40
Scope	<p>Business Professionals of America is the nation's premier Career and Technical Student Organization. Founded in 2017 as co-curricular chapter, Mariner BPA affords all Mariner Middle School students in Grades 7-8 to learn an extensive variety of essential skills in the areas of leadership, community service, business, marketing, and finance. Students not only learn how to apply said skills in the real-world, but are provided the opportunity to obtain industry recognized certifications. From there, students who wish to move from general to active member status, compete in a variety of individual and/or team events annually for both state and national awards (including scholarships). Our chapter pays all initial costs for an active member to join the state/national chapter and compete at/attend the State Leadership Conference. This includes, but does not include, dues, conference registrations, student travel assistance, etc... Dues vary based upon the size of our active members (those wishing to compete), while sending students to conferences can range in cost from \$5000-15000+ per conference (Delaware Leadership Conference + National Leadership Conference). Unfortunately, while we want our students to do well. Success comes at a cost. While we celebrate the accomplishments of our 2024-25 active members (#1 in USA), the cost to help send and support them at last year's National Leadership Conference in Chicago has left our</p>

chapter well short of the funds necessary to allow the 40 open seats to be filled. This means we will have to place restrictions on who can be an active and who can not; thus, depriving students of unmatched opportunities and a chance to earn needed scholarships. Many students will be deprived of the opportunity.

Please enter the current support your organization receives for this project (not entire organization revenue if not applicable to request) 1,500.00

Description Dues (State and National)

Amount 400.00

Description State of Delaware - State Leadership Conference

Amount 4,000.00

Description National Leadership Conference (Orlando, FL)

Amount 5,000.00

Description Transportation

Amount 3,000.00

Description Operating Costs (supplies, equipment, printing, etc...)

Amount 2,000.00

TOTAL EXPENDITURES 14,400.00

TOTAL DEFICIT FOR PROJECT OR ORGANIZATION -12,900.00

Name of Organization	Mariner BPA
Applicant/Authorized Official	Daniel Shockley
Date	10/09/2024
Affidavit Acknowledgement	Yes

If you feel this is not a valid submission please log into D3Forms to update this submissions status.
Please feel free to email clientservices@d3corp.com with any questions.

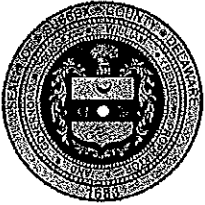

SUSSEX COUNTY GOVERNMENT
GRANT APPLICATION

Green

SECTION 1 APPLICANT INFORMATION

ORGANIZATION NAME: Greenwood Police Department

PROJECT NAME: Sussex County Community Policing Equipment

FEDERAL TAX ID: 510107189 NON-PROFIT: YES NO

DOES YOUR ORGANIZATION OR ITS PARENT ORGANIZATION HAVE A RELIGIOUS AFFILIATION?

YES NO *IF YES, FILL OUT SECTION 3B.

ORGANIZATION'S MISSION:

ADDRESS: 100 West Market St

<u>Greenwood</u>	<u>Delaware</u>	<u>19950</u>
(CITY)	(STATE)	(ZIP)

CONTACT PERSON: Kevin Eickman

TITLE: Grants Manager

PHONE: 302-349-4822 EMAIL: kevin.eickman@cj.state.de.us

TOTAL FUNDING REQUEST: \$22642.20

Has your organization received other grant funds from Sussex County Government in the last year? YES NO

If YES, how much was received in the last 12 months? \$36500.00

If you are asking for funding for building or building improvements, do you own the building in which the funding will be used for? YES NO

Are you seeking other sources of funding other than Sussex County Council? YES NO

If YES, approximately what percentage of the project's funding does the Council grant represent? _____

SECTION 2: PROGRAM DESCRIPTION

PROGRAM CATEGORY (choose all that apply)

- | | | |
|--|--|--------------------------------------|
| <input type="checkbox"/> Fair Housing | <input type="checkbox"/> Health and Human Services | <input type="checkbox"/> Cultural |
| <input type="checkbox"/> Infrastructure ¹ | <input checked="" type="checkbox"/> Other <u>Public Safety</u> | <input type="checkbox"/> Educational |

BENEFICIARY CATEGORY

- | | | |
|--|---|-----------------------------------|
| <input checked="" type="checkbox"/> Disability & Special Needs | <input checked="" type="checkbox"/> Victims of Domestic Violence | <input type="checkbox"/> Homeless |
| <input checked="" type="checkbox"/> Elderly Persons | <input type="checkbox"/> Low to Moderate Income ² | <input type="checkbox"/> Youth |
| <input checked="" type="checkbox"/> Minority | <input checked="" type="checkbox"/> Other <u>The entire community</u> | |

BENEFICIARY NUMBER

Approximately the total number of Sussex County Beneficiaries served annually by this program:
100,000 Plus

SECTION 3: PROGRAM SCORE

A. Briefly describe the program for which funds are being requested. The narrative should include the need or problem to be addressed in relation to the population to be served or the area to benefit.

1. Stalker radar equipment for traffic safety and enforcement:

Currently The Greenwood Police Department is using obsolete LIDAR equipment for traffic enforcement. This equipment has reached the end of life expectancy and needs to be replaced. Given the demonstrated accuracy of the Stalker radar system in use by The Delaware State Police, this would serve to increase accuracy in traffic enforcement in a very heavily traveled area of Sussex County.

2. Purchase of side arms and associated equipment:

The current side arms in use by The Greenwood Police Department were purchased over 10 years ago. We are seeking to have them replaced with Sig Sauer p320 side arms and associated equipment. The replacement of these items addresses the issue of more expensive and harder to come by ammunition. More importantly, the improvement in aiming sights provide a much improved level of accuracy in the event the weapon is drawn, thereby decreasing the risk to innocent bystanders.

3. Purchase of Axon Tasers, training and certification:

The current Tasers in use by The Town of Greenwood are obsolete and in need of replacement. Replacement cartridges are difficult, if not impossible to obtain. The package requested includes supplies and annual certification over a five (5) year period. This would be a valuable tool as opposed to deadly force in critical situations.

B. IF RELIGIOUS AFFILIATION WAS CONFIRMED ABOVE IN SECTION 1, PLEASE FILL OUT THE FOLLOWING SECTION. IF RELIGIOUS AFFILIATION WAS NOT CHECKED IN SECTION 1, THIS SECTION MAY BE LEFT BLANK.

A faith-based nonprofit organization is eligible to receive and apply for a grant on the same basis as other nonprofit organizations, with respect to programs which are eligible. In the selection of grantees, the County will not discriminate for or against an organization on the basis of the organization's religious characterization or affiliation. However, certain requests to utilize funding for programs with religious purposes may not be eligible due to constitutional principles of the United States and/or the State of Delaware.

Briefly describe the components of the program that involve religious purposes and the components that involve secular purposes, or non-religious purposes. If both non-religious and religious purposes are involved in the program, this narrative must include the specific actions that will be implemented in order to ensure that the funding is solely used for non-religious purposes and will not be used to advance or inhibit religious or faith-based activities.

After the awarded funds have been made, receipts of the non-religious purchases shall be submitted in accordance with Section 5 below before funds will be disbursed.

SECTION 4: BUDGET

REVENUE	
Please enter the current support your organization receives for this project (not entire organization revenue if not applicable to request)	
TOTAL REVENUES	
EXPENDITURES	
Please enter the total projected budget for the project (not entire organization expense if not applicable to request). Example of expenditure items: PERSONNEL-one lump sum that would include benefits; OPERATING COSTS-supplies, equipment, rent/lease, insurance, printing, telephone; CONSTRUCTION/ACQUISITION-acquisition, development, rehab, hard cost, physical inspections, architectural engineering, permits, and fees; insurance appraisal. (Put amounts in as a negative)	
(2) Stalker radar systems for Patrol Vehicles.	\$ 4,700.00
(3) Sig Sauer p320 sidearms and associated equipment.	\$ 3,321.00
(3) Axon Taser's and associated equipment and training for five years.	\$ 14,623.20
TOTAL EXPENDITURES	\$ 22,644.20
TOTAL DEFICIT FOR PROJECT OR ORGANIZATION	\$ 22,644.20

SECTION 5: STATEMENT OF ASSURANCES

If this grant application is awarded funding, the The Town of Greenwood Police Department agrees that:
(Name of Organization)

- 1) For non-religious organizations, all expenditures must have adequate documentation and must be expended within one (1) year of receipt of award funds. The funding awarded to the organization must be used in substantial conformity with the anticipated expenditures set forth in the submitted application. All accounting records and supporting documentation shall be available for inspection by Sussex County within thirty (30) days after the organization's expenditure of the awarded funding, or within one year after the receipt of the awarded funds, whichever first occurs.
- 2) For religious organizations, all accounting records and supporting documentation shall be provided for inspection by Sussex County after the award has been made by County Council but before the funding is released.
- 3) No person, on the basis of race, color, or national origin, should be excluded from participation in, be denied the benefit of, or be otherwise subjected to discrimination under the program or activity funded in whole or in part by these Grant funds.

SECTION 5: STATEMENT OF ASSURANCES (continued)

- 4) All information and statements in this application are accurate and complete to the best of my information and belief.
- 5) All funding will benefit only Sussex County residents.
- 6) All documents submitted by the applicant are defined as public documents and available for review under the Freedom of Information Act of the State of Delaware.
- 7) All funding will be used exclusively for secular purposes, i.e., non-religious purposes and shall not be used to advance or inhibit religious purposes.
- 8) **In the event that the awarded funding is used in violation of the requirements of this grant, the awarded funding shall be reimbursed to Sussex County within a timeframe designated by Sussex County by written notice.**

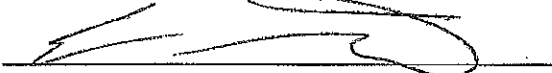
Applicant/Authorized Official Signature

9-30-2024
Date

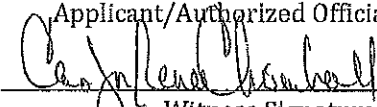
Witness Signature

9/30/24
Date

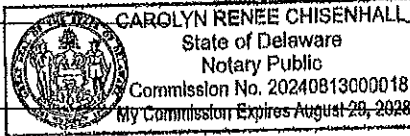

Completed application can be submitted by:

Email: gjennings@sussexcountyde.gov

Mail: Sussex County Government
Attention: Gina Jennings
PO Box 589
Georgetown, DE 19947

SUSSEX COUNTY COUNCIL NON-PROFIT GRANT PROGRAM
GUIDELINES FOR SUBMITTAL AND AFFIDAVIT OF UNDERSTANDING

The Sussex County Council makes available a limited amount of funding to non-profit organizations that serve the citizens of Sussex County. Each application for funding shall be evaluated by Sussex County administrative staff and shall be subject to final approval from Sussex County Council.

In the attached application, each organization must outline its intended uses for the awarded funding and provide a detailed breakdown of the expenses and costs for such uses. Any funding awarded to the organization must be used in substantial conformity with anticipated expenditures of the submitted application.

All expenditures must have adequate documentation and must be expended within one (1) year of award of funds.

For non-religious organizations, all accounting records and supporting documentation shall be available for inspection by Sussex County within thirty (30) days after the organization's expenditure of the awarded funding, or within one year after the receipt of the awarded funds, whichever first occurs.

For religious organizations, all accounting records and supporting documentation shall be provided for inspection by Sussex County after the award has been made by County Council but before funding is released. Grant is relinquished if supporting documentation is not provided within one year of County Council award.

Certain programs are not eligible for funding pursuant to United States Constitution and State of Delaware Constitution. Those constitutional principles prohibit the use of funding to advance or inhibit religious activities. By signing below, the organization acknowledges that the funding shall be used exclusively for secular purposes, i.e., non-religious purposes and shall not be used to advance or inhibit religious activities.

In the event that such funding is used in violation of the requirements and assurances contained in this grant application, the awarded funding shall be reimbursed to Sussex County within a timeframe designated by Sussex County by written notice.

I acknowledge and represent on behalf of the applicant organization that I have read and understand the above statements.

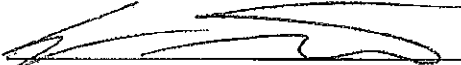
Applicant/Authorized Official Signature

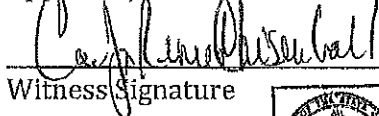
Witness Signature

Officer in Charge (Greenwood P.d.)
Title

9/30/24
Date

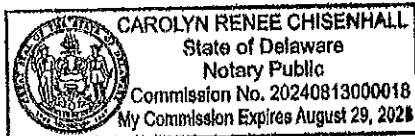



applied concepts, inc.

855 E. Collins Blvd
Richardson, TX 75081
Phone: 972-398-3780
Fax: 972-398-3781

National Toll Free: 1-800- STALKER

Inside Sales Partner: Vanna Moore
vanna.moore@a-concepts.com

QUOTE
2094799

Page 1 of 1

Date: 09/30/24

Reg Sales Mgr: Daniel Rinker
+1-214-755-6324
danielr@a-concepts.com

Effective From : 09/30/2024

Valid Through: 12/29/2024

Lead Time: 80 working days

Bill To: Greenwood Police Dept PO Box 208 Greenwood, DE 19950-0208	Customer ID: 199501 Accounts Payable	Ship To: Greenwood Police Dept 100 W Market St Greenwood, DE 19950-9401	<i>FedEx Ground</i> Sergeant William Thomas
--	--	---	--

Grp	Qty	Package	Description	Wrnty/Mo	Price	Ext Price
2	2	805-0022-00	Dual - 2 Antenna Radar System	36	\$2,350.00	\$4,700.00
Ln	Qty	Part Number	Description		Price	Ext Price
19	2	200-0998-50	Dual Enhanced Counting Unit, 1,5 PCB, ARM Processor			\$0.00
20	2	200-1571-00	Dual SL Modular OSC Display			\$0.00
21	4	200-1468-00	Dual DSR Ka Antenna			\$0.00
22	2	200-0920-00	Dual SL Remote Control w/Screw Latch			\$0.00
23	2	200-0769-00	25 MPH/40 KPH KA Tuning Fork			\$0.00
24	2	200-0770-00	40 MPH/64 KPH KA Tuning Fork			\$0.00
25	2	200-0243-00	Counting/Display Tall Mount			\$0.00
26	2	200-0244-00	Antenna Dash Mount			\$0.00
27	2	200-0245-00	Antenna Tall Deck Mount			\$0.00
28	2	200-0648-00	Display Sun Shield			\$0.00
29	2	155-2591-08	8 Foot Antenna Cable, IP67			\$0.00
30	2	155-2591-20	20 Foot Antenna Cable, IP67			\$0.00
31	2	200-0622-00	VSS Cable Kit			\$0.00
32	2	200-0820-00	Dual Manual Kit			\$0.00
33	2	006-0096-00	Fan Noise Suppression Addendum - Dual SL			\$0.00
34	2	035-0361-00	Shipping Container, Dash Mounted Radar			\$0.00
35	2	005-1468-00	Dual Certified Package			\$0.00
36	2	060-1000-36	36 Month Warranty			\$0.00

Group Total \$4,700.00

Product	\$4,700.00	Sub-Total:	\$4,700.00
Discount	\$0.00	Sales Tax 0%	\$0.00
		Shipping & Handling:	\$0.00
		Total: USD	\$4,700.00

Payment Terms: Net 30 days

Vehicle Information:
2023 Dodge Durango

001

This Quote or Purchase Order is subject in all respects to the Terms and Conditions detailed at the back of this document. These Terms and Conditions contain limitations of liability, waivers of liability even for our own negligence, and indemnification provisions, all of which may affect your rights. Please review these Terms and Conditions carefully before proceeding.

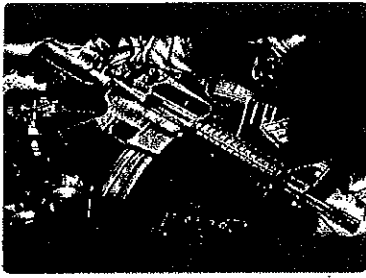

Quote

711

Date: Sep 29, 2024

Balance Due: \$3,321.00

FEDERAL FIREARM
1224 CHOPTANK ROAD
MIDDLETOWN, DE 19709

Bill To:

William Thomas
Greenwood Police

Item	Quantity	Rate	Amount
sig sauer p320 9mm pistol 3 mags romeo 1 pro optic suppressor	3	\$859.00	\$2,577.00
height night sights pro p320ca pro			
holster level 3 alien gear	3	\$159.00	\$477.00
light nightstick 550xls	3	\$89.00	\$267.00
		Subtotal:	\$3,321.00
		Tax (0%):	\$0.00
		Total:	\$3,321.00

Notes:

quantity can be adjusted based on needs

Terms:

William.c.thomas@cj.state.de.us



Axon Enterprise, Inc.
 17800 N 85th St
 Scottsdale, Arizona 85255
 United States
 VAT: 86-0741227
 Domestic: (800) 978-2737
 International: +1.800.978.2737

Q-615921-45559.694BS
 Issued: 09/24/2024
 Quote Expiration: 10/25/2024
 Estimated Contract Start Date: 02/01/2025
 Account Number: 327914
 Payment Terms: N80
 Delivery Method:

SHIP TO	BILL TO
Greenwood Police Dept. - DE 100 W Market St Greenwood, DE 19950-9401 USA	Greenwood Police Dept. - DE 100 W Market St Greenwood DE 19950-9401 USA Email:

SALES REPRESENTATIVE	PRIMARY CONTACT
Brooke Stahr Phone: 781-738-9403 Email: bstahr@axon.com Fax:	William Thomas Phone: (302) 349-4822 Email: william.c.thomas@sj.state.de.us Fax: (302) 349-4870

Quote Summary

Program Length	60 Months
TOTAL COST	\$14,623.20
ESTIMATED TOTAL W/ TAX	\$14,623.20

Discount Summary

Average Savings Per Year	\$1,448.28
TOTAL SAVINGS	\$7,241.40

Quote Unbundled Price: \$21,864.50
 Quote List Price: \$14,623.20
 Quote Subtotal: \$14,623.20

Pricing

All deliverables are detailed in Delivery Schedules section lower in proposal

Item	Description	Qty	Term	Unbundled	List Price	Net Price	Subtotal	Tax	Total
Program									
C00010	BUNDLE - TASER 10 CERTIFICATION	3	60	\$121.47	\$81.24	\$81.24	\$14,623.20	\$0.00	\$14,623.20
Total							\$14,623.20	\$0.00	\$14,623.20

Delivery Schedule

Hardware

Bundle	Item	Description	Qty	Shipping Location	Estimated Delivery Date
BUNDLE - TASER 10 CERTIFICATION	100390	AXON TASER 10 - HANDLE - YELLOW CLASS 3R	3	2	01/01/2025
BUNDLE - TASER 10 CERTIFICATION	100393	AXON TASER 10 - MAGAZINE - LIVE DUTY BLACK	3	1	01/01/2025
BUNDLE - TASER 10 CERTIFICATION	100394	AXON TASER 10 - MAGAZINE - HALT TRAINING BLUE	4	1	01/01/2025
BUNDLE - TASER 10 CERTIFICATION	100395	AXON TASER 10 - MAGAZINE - LIVE TRAINING PURPLE	3	1	01/01/2025
BUNDLE - TASER 10 CERTIFICATION	100396	AXON TASER 10 - MAGAZINE - INERT RED	3	1	01/01/2025
BUNDLE - TASER 10 CERTIFICATION	100399	AXON TASER 10 - CARTRIDGE - LIVE	60	1	01/01/2025
BUNDLE - TASER 10 CERTIFICATION	100400	AXON TASER 10 - CARTRIDGE - HALT	20	1	01/01/2025
BUNDLE - TASER 10 CERTIFICATION	100401	AXON TASER 10 - CARTRIDGE - INERT	30	1	01/01/2025
BUNDLE - TASER 10 CERTIFICATION	100611	AXON TASER 10 - SAFARI AND HOLSTER - RH	3	1	01/01/2025
BUNDLE - TASER 10 CERTIFICATION	100623	AXON TASER - TRAINING - ENHANCED HALT SUIT V2	1	1	01/01/2025
BUNDLE - TASER 10 CERTIFICATION	20018	AXON TASER - BATTERY PACK - TACTICAL	1	1	01/01/2025
BUNDLE - TASER 10 CERTIFICATION	20018	AXON TASER - BATTERY PACK - TACTICAL	3	1	01/01/2025
BUNDLE - TASER 10 CERTIFICATION	70033	AXON - DOCK WALL MOUNT - BRACKET ASSY	1	1	01/01/2025
BUNDLE - TASER 10 CERTIFICATION	71919	AXON BODY - DOCK POWERCORD - NORTH AMERICA	1	1	01/01/2025
BUNDLE - TASER 10 CERTIFICATION	74200	AXON TASER - DOCK - SIX BAY PLUS CORE	1	1	01/01/2025
BUNDLE - TASER 10 CERTIFICATION	80087	AXON TASER - TARGET - CONDUCTIVE PROFESSIONAL RUGGEDIZED	1	1	01/01/2025
BUNDLE - TASER 10 CERTIFICATION	80090	AXON TASER - TARGET FRAME - PROFESSIONAL 27.5 IN X 7.5 IN	1	1	01/01/2025
BUNDLE - TASER 10 CERTIFICATION	100399	AXON TASER 10 - CARTRIDGE - LIVE	10	1	01/01/2025
BUNDLE - TASER 10 CERTIFICATION	100400	AXON TASER 10 - CARTRIDGE - HALT	30	1	01/01/2025
BUNDLE - TASER 10 CERTIFICATION	100399	AXON TASER 10 - CARTRIDGE - LIVE	10	1	01/01/2027
BUNDLE - TASER 10 CERTIFICATION	100400	AXON TASER 10 - CARTRIDGE - HALT	20	1	01/01/2027
BUNDLE - TASER 10 CERTIFICATION	100399	AXON TASER 10 - CARTRIDGE - LIVE	10	1	01/01/2028
BUNDLE - TASER 10 CERTIFICATION	100400	AXON TASER 10 - CARTRIDGE - HALT	30	1	01/01/2028
BUNDLE - TASER 10 CERTIFICATION	100399	AXON TASER 10 - CARTRIDGE - LIVE	10	1	01/01/2028
BUNDLE - TASER 10 CERTIFICATION	100400	AXON TASER 10 - CARTRIDGE - HALT	20	1	01/01/2029

Software

Bundle	Item	Description	QTY	Estimated Start Date	Estimated End Date
--------	------	-------------	-----	----------------------	--------------------

Software

Bundle	Item	Description	QTY	Estimated Start Date	Estimated End Date
BUNDLE - TASER 10 CERTIFICATION	101180	AXON TASER - DATA SCIENCE PROGRAM	3	02/01/2025	01/31/2030
BUNDLE - TASER 10 CERTIFICATION	20248	AXON TASER - EVIDENCE COM.LICENSE	3	02/01/2025	01/31/2030
BUNDLE - TASER 10 CERTIFICATION	20248	AXON TASER - EVIDENCE COM.LICENSE	1	02/01/2025	01/31/2030

Services

Bundle	Item	Description	QTY
BUNDLE - TASER 10 CERTIFICATION	100751	AXON TASER 10 - REPLACEMENT ACCESS PROGRAM - DUTY CARTRIDGE	3
BUNDLE - TASER 10 CERTIFICATION	101193	AXON TASER - ON DEMAND CERTIFICATION	1

Warranties

Bundle	Item	Description	QTY	Estimated Start Date	Estimated End Date
BUNDLE - TASER 10 CERTIFICATION	100704	AXON TASER 10 - EXT WARRANTY - HANDLE	3	01/01/2026	01/31/2030
BUNDLE - TASER 10 CERTIFICATION	80374	AXON TASER - EXT WARRANTY - BATTERY PACK 7/7/10	3	01/01/2026	01/31/2030
BUNDLE - TASER 10 CERTIFICATION	80374	AXON TASER - EXT WARRANTY - BATTERY PACK 7/7/10	1	01/01/2026	01/31/2030
BUNDLE - TASER 10 CERTIFICATION	80396	AXON TASER - EXT WARRANTY - DOCK SIX BAY 7/7/10	1	01/01/2026	01/31/2030

Payment Summary

Date	Subtotal	Tax	Total
Jan 2025	\$2,924.64	\$0.00	\$2,924.64
Jan 2026	\$2,924.64	\$0.00	\$2,924.64
Jan 2027	\$2,924.64	\$0.00	\$2,924.64
Jan 2028	\$2,924.64	\$0.00	\$2,924.64
Jan 2029	\$2,924.64	\$0.00	\$2,924.64
Total	\$14,623.20	\$0.00	\$14,623.20

Shipping Locations

Location Number	Street	City	State	ZIP	Country
1	100 W Market St	Greenwood	DE	19950-9401	USA
2	100 W Market St	Greenwood	DE	19950-9401	USA

Payment Details

Invoice Plan	Item	Description	Qty	Subtotal	Tax	Total
Year 1	C00010	BUNDLE - TASER 10 CERTIFICATION	3	\$2,924.64	\$0.00	\$2,924.64
Total				\$2,924.64	\$0.00	\$2,924.64

Invoice Plan	Item	Description	Qty	Subtotal	Tax	Total
Year 2	C00010	BUNDLE - TASER 10 CERTIFICATION	3	\$2,924.64	\$0.00	\$2,924.64
Total				\$2,924.64	\$0.00	\$2,924.64

Invoice Plan	Item	Description	Qty	Subtotal	Tax	Total
Year 3	C00010	BUNDLE - TASER 10 CERTIFICATION	3	\$2,924.64	\$0.00	\$2,924.64
Total				\$2,924.64	\$0.00	\$2,924.64

Invoice Plan	Item	Description	Qty	Subtotal	Tax	Total
Year 4	C00010	BUNDLE - TASER 10 CERTIFICATION	3	\$2,924.64	\$0.00	\$2,924.64
Total				\$2,924.64	\$0.00	\$2,924.64

Invoice Plan	Item	Description	Qty	Subtotal	Tax	Total
Year 5	C00010	BUNDLE - TASER 10 CERTIFICATION	3	\$2,924.64	\$0.00	\$2,924.64
Total				\$2,924.64	\$0.00	\$2,924.64

Tax is estimated based on rates applicable at date of quote and subject to change at time of invoicing. If a tax exemption certificate should be applied, please submit prior to invoicing.

Standard Terms and Conditions

Axon Enterprise Inc. Sales Terms and Conditions

Axon Master Services and Purchasing Agreement

This Quote is limited to and conditional upon your acceptance of the provisions set forth herein and Axon's Master Services and Purchasing Agreement (posted at <https://www.axon.com/sales-terms-and-conditions>), as well as the attached Statement of Work (SOW) for Axon Fleet and/or Axon Interview Room purchase, if applicable. In the event you and Axon have entered into a prior agreement to govern all future purchases, that agreement shall govern to the extent it includes the products and services being purchased and does not conflict with the Axon Customer Experience Improvement Program Appendix as described below.

ACEIP:

The Axon Customer Experience Improvement Program Appendix, which includes the sharing of de-identified segments of Agency Content with Axon to develop new products and improve your product experience (posted at www.axon.com/legal/sales-terms-and-conditions), is incorporated herein by reference. By signing below, you agree to the terms of the Axon Customer Experience Improvement Program.

Acceptance of Terms:

Any purchase order issued in response to this Quote is subject solely to the above referenced terms and conditions. By signing below, you represent that you are lawfully able to enter into contracts. If you are signing on behalf of an entity (including but not limited to the company, municipality, or government agency for whom you work), you represent to Axon that you have legal authority to bind that entity. If you do not have this authority, please do not sign this Quote.

Signature

Date Signed

9/24/2024

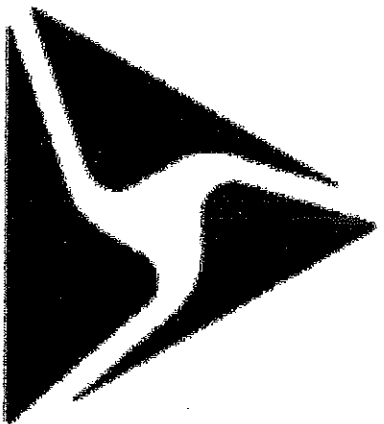

Casey Hall

Vincent 10/14

From: notifications=d3forms.com@mg.d3forms.com on behalf of Sussex County DE <notifications@d3forms.com>
Sent: Monday, October 14, 2024 3:15 PM
To: Casey Hall
Subject: Form submission from: Council Grant Form

CAUTION: This email originated from outside of the organization. Do not click links, open attachments, or reply unless you recognize the sender and know the content is safe. Contact the IT Helpdesk if you need assistance.

Council Grant Form

Legal Name of Agency/Organization	Laurel Lions Club Foundation
Project Name	Laurel Lions Club Recreation Complex
Federal Tax ID	510371085
Non-Profit	Yes
Does your organization or its parent organization have a religious affiliation? (If yes, fill out Section 3B.)	No
Organization's Mission	Serve the people of the Laurel area.
Address	P. O. Box 10
City	Laurel
State	DE
Zip Code	19956
Contact Person	John J. Shwed

Contact Title	Fund Raising Chairman
Contact Phone Number	3028414007
Contact Email Address	jjshwed@comcast.net
Total Funding Request	\$5,000
Has your organization received other grant funds from Sussex County Government in the last year?	No
If YES, how much was received in the last 12 months?	N/A
Are you seeking other sources of funding other than Sussex County Council?	Yes
If YES, approximately what percentage of the project's funding does the Council grant represent?	5
Program Category (choose all that apply)	Health and Human Services Other
Program Category Other	Recreation

Primary Beneficiary Category	Other
Beneficiary Category Other	All persons
Approximately the total number of Sussex County Beneficiaries served, or expected to be served, annually by this program	1500
Scope	The funds are requested to install one tennis court and two pickle ball courts to be located on the property of the North Laurel Early Learning Academy. First Phase of the Recreation Complex has been completed, which included the install of two full length basketball courts.
Religious Components	N/A
Please enter the current support your organization receives for this project (not entire organization revenue if not applicable to request)	37,000.00
Description	Concrete for Courts
Amount	61,000.00
Description	Court Surface and needed equipment
Amount	54,000.00
TOTAL EXPENDITURES	115,000.00

TOTAL DEFICIT FOR PROJECT OR ORGANIZATION	-78,000.00
Name of Organization	Laurel Lions Club
Applicant/Authorized Official	John J. Shwed
Date	10/14/2024
Affidavit Acknowledgement	Yes

If you feel this is not a valid submission please log into D3Forms to update this submissions status.
Please feel free to email clientservices@d3corp.com with any questions.

Casey Hall

From: notifications=d3forms.com@mg.d3forms.com on behalf of Sussex County DE <notifications@d3forms.com>
Sent: Tuesday, October 15, 2024 9:55 PM
To: Casey Hall
Subject: Form submission from: Council Grant Form

CAUTION: This email originated from outside of the organization. Do not click links, open attachments, or reply unless you recognize the sender and know the content is safe. Contact the IT Helpdesk if you need assistance.

Council Grant Form

Legal Name of Agency/Organization Grace -N- Mercy Ministries, Inc.

Project Name Thanksgiving Community Dinner

Federal Tax ID 38-3655598

Non-Profit Yes

Does your organization or its parent organization have a religious affiliation? (If yes, fill out Section 3B.) Yes

Organization's Mission To serve the community during the holiday for less fortunate people who would not otherwise have a traditional dinner.

Address PO BOX 70

City Greenwood

State DE

Zip Code 19950

Contact Person	TONEKIA SHOWELL
Contact Title	Secretary
Contact Phone Number	4438594763
Contact Email Address	tonekia.showell@seaford.k12.de.us
Total Funding Request	3000.00
Has your organization received other grant funds from Sussex County Government in the last year?	No
If YES, how much was received in the last 12 months?	N/A
Are you seeking other sources of funding other than Sussex County Council?	Yes
If YES, approximately what percentage of the project's funding does the Council grant represent?	50
Program Category (choose all that apply)	Health and Human Services Other
Program Category Other	Poverty/Pubic Assistance

Primary Beneficiary Category	Other
Beneficiary Category Other	Homeless, Elderly (62+), Disability & Special Needs
Approximately the total number of Sussex County Beneficiaries served, or expected to be served, annually by this program	500
Scope	<p>For the last 18 years, we have served Sussex County with the Annual Thanksgiving Dinner. It has grown to serve over 500 meals. Last year we served 593 meals to the homeless, elderly, and low to moderate-income citizens in Sussex County. We served individuals from Greenwood, Bridgeville, Seaford, Laurel, Delmar, Millsboro, Georgetown and Selbyville. These individuals were from local group homes (Delaware Mentor, Chimes, Stockley Center and Fellowship Resources). We also have individuals from hotels and motels in Sussex County. Some come to our location and others we take and pass out at these locations and local parks in the areas.</p> <p>According to statistics, over 153,000 people in Delaware, or 38% of the population, live below the poverty line or below the ALICE threshold, the bare minimum survival budget (Delaware Public Media).</p>
Religious Components	The Thanksgiving Community Dinner has no religious affiliation. The 501c3 is in the church's name. We use the location of the church to serve the dinner.
Please enter the current support your organization receives for this project (not entire organization)	500.00

revenue if not applicable to request)

Description 600 To Go Trays (125ct. x 7) (\$17)

Amount 119.00

Description 1000 drinking cups (1 box) (\$38)

Amount 38.00

Description 50 Turkeys x \$20 each

Amount 1,000.00

Description Green Beans (100 cans x \$6)

Amount 600.00

Description 500 pounds of mashed potatoes (9 x 80 boxes)

Amount 720.00

Description 720 Dinner Rolls (30 packs) x \$4

Amount 120.00

Description Variety of desserts (30 cakes and 30 pies x \$8)

Amount 480.00

Description Stuffing (20 pans) (\$8 per box of 6: need 40 boxes)

Amount 320.00

TOTAL EXPENDITURES 3,397.00

TOTAL DEFICIT FOR PROJECT OR ORGANIZATION	-2,897.00
Name of Organization	Grace -N- Mercy Ministries, Inc.
Applicant/Authorized Official	TONEKIA SHOWELL
Date	10/15/2024
Affidavit Acknowledgement	Yes

If you feel this is not a valid submission please log into D3Forms to update this submissions status.
Please feel free to email clientservices@d3corp.com with any questions.

Casey Hall

From: notifications=d3forms.com@mg.d3forms.com on behalf of Sussex County DE <notifications@d3forms.com>
Sent: Tuesday, October 15, 2024 10:53 AM
To: Casey Hall
Subject: Form submission from: Council Grant Form

CAUTION: This email originated from outside of the organization. Do not click links, open attachments, or reply unless you recognize the sender and know the content is safe. Contact the IT Helpdesk if you need assistance.

Council Grant Form

Legal Name of Agency/Organization Bridgeville Public Library

Project Name Mini Library

Federal Tax ID 51-0242487

Non-Profit Yes

Does your organization or its parent organization have a religious affiliation? (If yes, fill out Section 3B.) No

Organization's Mission The Bridgeville Public Library provides free and welcoming access to quality resources and innovative services in ways that appeal to public interest through a variety of formats to access information, knowledge, and ideas.

Address 600 S Cannon St

City Bridgeville

State De

Zip Code 19933

Contact Person	Karen Johnson-Kemp
Contact Title	Library Director
Contact Phone Number	302-337-7401
Contact Email Address	mstoyasg@gmail.com
Total Funding Request	1800.00
Has your organization received other grant funds from Sussex County Government in the last year?	No
If YES, how much was received in the last 12 months?	N/A
Are you seeking other sources of funding other than Sussex County Council?	Yes
If YES, approximately what percentage of the project's funding does the Council grant represent?	5
Program Category (choose all that apply)	Educational
Primary Beneficiary Category	Low to Moderate Income

Approximately the total number of Sussex County Beneficiaries served, or expected to be served, annually by this program

2200

Scope

Bridgeville Public Library is seeking to expand the library's services for the Bridgeville Community. As a vital community hub, the Bridgeville Public Library provides educational, cultural, and informational resources to individuals of all ages and backgrounds, contributing to the overall well-being and development of Sussex County's residents.

Currently, our library offers an array of free programs and services, including literacy programs for children, technology training for adults, and community enrichment activities for seniors. In Fiscal year 2024, we have hosted 265 adult programs, 287 youth programs, and engaged a total of 21,565 community members including individuals from surrounding communities. We also provide crucial access to computers and internet services for patrons who do not have these resources at home. With rapid changes in technology and the growing demand for digital literacy our library is committed to meeting the evolving needs of our community.

We are requesting financial assistance as we make efforts to move into an underserved and low income segment of our community. The Coverdale community and the Walkers Mill Community are both outside of town limits and have several barriers that impede community members from getting into town to our library. Provide a mini library in their community buildings will increase literacy for the youth and adults within those communities. A mini library will allow us to enhance early literacy programs to reach young children and families and ensure that every child in our community has access to the tools needed to develop strong reading skills. Our presences in these communities will also all us to host community engagement, educational programs, workshops, cultural events, and family friendly activities in these communities which will aid in fostering a

sense of community and lifelong learning. The Bridgeville Public Library is a trusted institution that plays a key role in the social and educational development of our community. Your support would enable us to continue serving as a cornerstone for learning and engagement, particularly for those who have barriers and financial disadvantages.

Please enter the current support your organization receives for this project (not entire organization revenue if not applicable to request)	0.00
Description	6 Revolving Literacy Towers
Amount	1,800.00
TOTAL EXPENDITURES	1,800.00
TOTAL DEFICIT FOR PROJECT OR ORGANIZATION	-1,800.00
Name of Organization	Bridgeville Public Library
Applicant/Authorized Official	Karen Johnson-Kemp
Date	10/15/2024
Affidavit Acknowledgement	Yes

If you feel this is not a valid submission please log into D3Forms to update this submissions status. Please feel free to email clientservices@d3corp.com with any questions.

Casey Hall

From: notifications=d3forms.com@mg.d3forms.com on behalf of Sussex County DE <notifications@d3forms.com>
Sent: Monday, October 14, 2024 11:50 AM
To: Casey Hall
Subject: Form submission from: Council Grant Form

CAUTION: This email originated from outside of the organization. Do not click links, open attachments, or reply unless you recognize the sender and know the content is safe. Contact the IT Helpdesk if you need assistance.

Council Grant Form

Legal Name of Agency/Organization Cornerstone Community Center

Project Name Kids Against Tobacco

Federal Tax ID 86-3066808

Non-Profit Yes

Does your organization or its parent organization have a religious affiliation? (If yes, fill out Section 3B.) No

Organization's Mission At Cornerstone Community Center, our mission is to further the common good and general welfare of the community by encouraging and strengthening education and addressing mental, emotional, and physical health disparities within the community.

Address 100 Market St

City Bridgeville

State De

Zip Code	19933
Contact Person	Latoya Harris
Contact Title	Executive Director
Contact Phone Number	3023443712
Contact Email Address	cornerstoneccllc21@gmail.com
Total Funding Request	3000
Has your organization received other grant funds from Sussex County Government in the last year?	No
If YES, how much was received in the last 12 months?	N/A
Are you seeking other sources of funding other than Sussex County Council?	No
If YES, approximately what percentage of the project's funding does the Council grant represent?	N/A
Program Category (choose all that apply)	Educational

Primary Beneficiary Category	Youth
Approximately the total number of Sussex County Beneficiaries served, or expected to be served, annually by this program	50
Scope	<p>Our Kids Against Tobacco program is part of the Kick Butts Generation youth group. Currently, we have 12 members who meet monthly to learn about the dangers of tobacco and nicotine. These young individuals are then empowered to educate their peers and the community, with the goal of increasing cessation efforts, reducing the number of Delaware youth using tobacco products, and preventing exposure to secondhand smoke in homes and schools.</p> <p>Our youth have traveled across the state, gaining insights into the harmful effects of smoking and vaping. In May of this year, both our Force Ambassador and our youngest member were among 30 Delaware youth who joined the Governor and members of Legislative Hall for Prevention Day in Dover.</p> <p>To continue their learning, our youth attend summits throughout the state, focusing on the dangers of tobacco and e-cigarettes. Statistics show that nearly 800 Delaware youth become daily smokers each year, and tragically, 17,000 under the age of 18 are projected to die prematurely from smoking. With the rising popularity of vaping among younger ages, it is crucial that our youth are educated, empowered, and encouraged to engage their peers in the fight to break this cycle and avoid becoming another statistic</p>
Please enter the current support your organization receives	250.00

**for this project (not
entire organization
revenue if not
applicable to request)**

Description Travel for the year

Amount 300.00

Description Monthly meals for force meetings for the year

Amount 1,000.00

Description Marketing for community events

Amount 1,500.00

Description Vending fees for events

Amount 200.00

TOTAL EXPENDITURES 3,000.00

**TOTAL DEFICIT FOR
PROJECT OR
ORGANIZATION** -2,750.00

Name of Organization Cornerstone Community Center

**Applicant/Authorized
Official** Latoya Harris

Date 10/14/2024

**Affidavit
Acknowledgement** Yes

If you feel this is not a valid submission please log into D3Forms to update this submissions status.
Please feel free to email clientservices@d3corp.com with any questions.

Casey Hall

From: notifications=d3forms.com@mg.d3forms.com on behalf of Sussex County DE <notifications@d3forms.com>
Sent: Thursday, October 3, 2024 8:36 AM
To: Casey Hall
Subject: Form submission from: Council Grant Form

CAUTION: This email originated from outside of the organization. Do not click links, open attachments, or reply unless you recognize the sender and know the content is safe. Contact the IT Helpdesk if you need assistance.

Council Grant Form

Legal Name of Agency/Organization Town of Blades

Project Name Town of Blades Annual Kids Christmas Party

Federal Tax ID 51-6001393

Non-Profit Yes

Does your organization or its parent organization have a religious affiliation? (If yes, fill out Section 3B.) No

Organization's Mission To provide laughter and fun to local children. They get to meet Mr. and Mrs. Claus, who provides them with a gift. Games and snacks are also enjoyed during their time.

Address 20 W Fourth St

City Blades

State DE

Zip Code 19973

Contact Person	Crystal Gregor
Contact Phone Number	3026297366
Contact Email Address	adminasst@townofblades.com
Total Funding Request	250
Has your organization received other grant funds from Sussex County Government in the last year?	No
If YES, how much was received in the last 12 months?	N/A
Are you seeking other sources of funding other than Sussex County Council?	Yes
If YES, approximately what percentage of the project's funding does the Council grant represent?	10
Program Category (choose all that apply)	Other
Program Category Other	Christmas

Primary Beneficiary Category	Youth
Approximately the total number of Sussex County Beneficiaries served, or expected to be served, annually by this program	100
Scope	This is an annual Christmas party that the Town of Blades puts on for the local children in our community. We also let parents know in our area with children that are more on the low-income population to make sure they get to enjoy some of the fun.
Please enter the current support your organization receives for this project (not entire organization revenue if not applicable to request)	2,500.00
Description	Gifts for 100 Children
Amount	1,500.00
Description	Food/Snacks
Amount	500.00
Description	Games
Amount	250.00
Description	Decorations
Amount	250.00

TOTAL EXPENDITURES	2,500.00
TOTAL DEFICIT FOR PROJECT OR ORGANIZATION	0.00
Name of Organization	Town of Blades
Applicant/Authorized Official	Crystal Gregor
Date	10/03/2024
Affidavit Acknowledgement	Yes

If you feel this is not a valid submission please log into D3Forms to update this submissions status.
Please feel free to email clientservices@d3corp.com with any questions.

Casey Hall

From: notifications=d3forms.com@mg.d3forms.com on behalf of Sussex County DE <notifications@d3forms.com>
Sent: Tuesday, October 8, 2024 10:43 AM
To: Casey Hall
Subject: Form submission from: Council Grant Form

CAUTION: This email originated from outside of the organization. Do not click links, open attachments, or reply unless you recognize the sender and know the content is safe. Contact the IT Helpdesk if you need assistance.

Council Grant Form

Legal Name of Agency/Organization Nanticoke Senior Center

Project Name Media Center/Educational Program

Federal Tax ID 23-7202136

Non-Profit Yes

Does your organization or its parent organization have a religious affiliation? (If yes, fill out Section 3B.) No

Organization's Mission We provide a place for members %0+ to meet and participate in leisure and educational activities that address their health, happiness and independence. We also offer a homebound meal program for seniors in our community who have food insufficiencies. Our center provides meals to seniors regardless of their ability to pay.

Address 1001 W Locust Street

Address 2 PO Box 406

City Seaford

State	DE
Zip Code	19973
Contact Person	Margaret Parks
Contact Title	Assistant Director
Contact Phone Number	3026294939
Contact Email Address	margaret.parks@nanticokeseniorcenter.com
Total Funding Request	10,000.00
Has your organization received other grant funds from Sussex County Government in the last year?	Yes
If YES, how much was received in the last 12 months?	6000
Are you seeking other sources of funding other than Sussex County Council?	No
If YES, approximately what percentage of the project's funding does the Council grant represent?	N/A

Program Category (choose all that apply)	Cultural Educational Health and Human Services
Primary Beneficiary Category	Elderly Persons (62 +)
Approximately the total number of Sussex County Beneficiaries served, or expected to be served, annually by this program	1000
Scope	Nanticoke Senior Center provides services to members of the Seaford community as well as surrounding communities. We offer classes on defensive driving, tax preparations, and fraud seminars. We also have concerts, birthday parties with entertainment, trivia, show movies and other activities, We are a very active center and today's seniors want to enjoy a more active lifestyle. Our media equipment needs to be up dated to keep up with modern technology. If we can have a dedicated media center, we can enhance their experiences.
Religious Components	N/A
Please enter the current support your organization receives for this project (not entire organization revenue if not applicable to request)	0.00
Description	Purchase needed equipment and installation
Amount	10,000.00

Amount	0.00
Description	Equipment
Amount	0.00
Amount	0.00
TOTAL EXPENDITURES	10,000.00
TOTAL DEFICIT FOR PROJECT OR ORGANIZATION	-10,000.00
Name of Organization	Nanticoke Senior Center
Applicant/Authorized Official	Margaret Parks
Date	10/08/2024
Affidavit Acknowledgement	Yes

If you feel this is not a valid submission please log into D3Forms to update this submissions status.
Please feel free to email clientservices@d3corp.com with any questions.

Casey Hall

From: notifications=d3forms.com@mg.d3forms.com on behalf of Sussex County DE <notifications@d3forms.com>
Sent: Wednesday, October 16, 2024 8:33 AM
To: Casey Hall
Subject: Form submission from: Council Grant Form

CAUTION: This email originated from outside of the organization. Do not click links, open attachments, or reply unless you recognize the sender and know the content is safe. Contact the IT Helpdesk if you need assistance.

Council Grant Form

Legal Name of Agency/Organization Seaford Tomorrow

Project Name Friday Night Live

Federal Tax ID 47-5519548

Non-Profit Yes

Does your organization or its parent organization have a religious affiliation? (If yes, fill out Section 3B.) No

Organization's Mission To make Downtown Seaford an experiential destination with a thriving, active downtown community consisting of a combination of art, dining, historical, and business attractions, leveraging natural and historical resources for the long-term economic well-being of the community.

Address 414 High Street

Address 2 PO BOX 1100

City Seaford

State	Delaware
Zip Code	19973
Contact Person	Katie Hickey
Contact Title	Event Coordinator
Contact Phone Number	3027455221
Contact Email Address	khickey@seafordde.com
Total Funding Request	\$2,500.00
Has your organization received other grant funds from Sussex County Government in the last year?	Yes
If YES, how much was received in the last 12 months?	1500.00
Are you seeking other sources of funding other than Sussex County Council?	Yes
If YES, approximately what percentage of the project's funding does the Council grant represent?	25

Program Category (choose all that apply)	Cultural Other
Program Category Other	community outreach
Primary Beneficiary Category	Low to Moderate Income
Approximately the total number of Sussex County Beneficiaries served, or expected to be served, annually by this program	1600
Scope	<p>Seaford Tomorrow is our non-profit that was created to immerse the community into Seaford's Downtown district. Seaford has recently seen revitalization of the downtown with new shops and restaurants. In order to bring people to the downtown, we created an event formerly known as "1st Saturdays" that is now known as "Friday Night Live".</p> <p>This event has been ongoing for over 8 years and is a free 3-hour outdoor event, suitable for all ages. It used to be hosted once per month from May - Oct, but grew so much in 2023, the organization decided to add two additional events in 2024. Our organization hires local musicians/bands to perform and asks a variety of local food/dessert trucks to attend to help support them as well. We provide outdoor games to support families who want to attend and encourage all attendees to visit the downtown shops/restaurants while they are downtown.</p> <p>Our only income is provided by the local beer/wines we sell during the event. Friday Night Live recently moved venues from a grass lot on High Street to a larger lot across the street, and while we are ecstatic about the growth, our organization continues to struggle to keep this event free to</p>

the community due to the rising costs of supplies, games, alcohol, and entertainment. We appreciate your support in the past years of our event - without small grants and few sponsorships, we could not be able to provide the community with this event. Thank you for your time and consideration for Seaford Tomorrow.

Please enter the current support your organization receives for this project (not entire organization revenue if not applicable to request) 6,700.00

Description Advertising

Amount 900.00

Description Logistics & Licenses

Amount 800.00

Description Supplies

Amount 3,000.00

Description Entertainment

Amount 6,000.00

TOTAL EXPENDITURES 10,700.00

TOTAL DEFICIT FOR PROJECT OR ORGANIZATION -4,000.00

Name of Organization Seaford Tomorrow

Applicant/Authorized Official	Katie Hickey
Date	10/16/2024
Affidavit Acknowledgement	Yes

If you feel this is not a valid submission please log into D3Forms to update this submissions status.
Please feel free to email clientservices@d3corp.com with any questions.

Casey Hall

From: notifications=d3forms.com@mg.d3forms.com on behalf of Sussex County DE <notifications@d3forms.com>
Sent: Thursday, October 17, 2024 2:04 PM
To: Casey Hall
Subject: Form submission from: Council Grant Form

CAUTION: This email originated from outside of the organization. Do not click links, open attachments, or reply unless you recognize the sender and know the content is safe. Contact the IT Helpdesk if you need assistance.

Council Grant Form

Legal Name of Agency/Organization	First State Community Action Agency, Inc.
Project Name	Anniversary Celebration
Federal Tax ID	51-0104704
Non-Profit	Yes
Does your organization or its parent organization have a religious affiliation? (If yes, fill out Section 3B.)	No
Organization's Mission	To work towards the elimination of poverty and lessen the effects of poverty on people with low incomes
Address	308 N. Railroad Ave.
Address 2	308 N. Railroad Ave.
City	Georgetown
State	DELAWARE
Zip Code	19947

Contact Person	Jaime Sayler
Contact Title	Director - Housing and Community Development
Contact Phone Number	3028567761
Contact Email Address	jsayler@firststatecaa.org
Total Funding Request	3000
Has your organization received other grant funds from Sussex County Government in the last year?	Yes
If YES, how much was received in the last 12 months?	57500
Are you seeking other sources of funding other than Sussex County Council?	Yes
If YES, approximately what percentage of the project's funding does the Council grant represent?	1
Program Category (choose all that apply)	Health and Human Services
Primary Beneficiary Category	Low to Moderate Income

Approximately the total number of Sussex County Beneficiaries served, or expected to be served, annually by this program

11500

Scope

First State Community Action Agency respectfully requests your sponsorship for its 59th annual anniversary celebration, Mosaic of Hope: Celebrating Diversity and Potential. This year's theme highlights our organization's unwavering commitment to fostering a more inclusive and equitable community.

The celebration will feature networking opportunities, a keynote address by a distinguished speaker, highlights of our agency's successes over the past year, a formal meal, and much more. Proceeds from the event will be allocated directly to support our comprehensive programs designed to empower low-income individuals and families to achieve economic stability and self-sufficiency.

Our programs include:

- Job training and placement services: Providing essential skills and resources to help individuals secure gainful employment in high-demand fields.
- Housing assistance: Supporting affordable housing options and homeownership programs, including down payment assistance and financial counseling.
- Financial literacy education: Empowering individuals with the knowledge and tools to manage their finances effectively, reduce debt, and build savings.
- Youth development programs: Providing mentorship, academic support, and recreational activities to help young people reach their full potential.
- And MUCH more!

By sponsoring our anniversary celebration, you will not only contribute to a meaningful community event but also invest in the future of our most vulnerable residents. Your support will enable us to continue breaking down barriers, building bridges, and creating a more hopeful and prosperous community for all.

Your sponsorship will directly support:

- Program costs: Enabling us to reach more individuals in need and increase the impact of our services.
- Staff training and professional development: Ensuring our team is equipped with the latest tools and knowledge to deliver effective programs.
- Community outreach and engagement: Strengthening our partnerships with local organizations and businesses to create a more cohesive community.

We believe that your investment in our anniversary celebration will be a valuable contribution to the well-being of our community and a demonstration of your commitment to our most vulnerable neighbors. Your sponsorship will not only help us celebrate our 59 years of service but also demonstrate your dedication to creating a more equitable and inclusive future for all. Join us in celebrating diversity, empowering individuals, and building a stronger community together.

Please enter the current support your organization receives for this project (not entire organization revenue if not applicable to request)

32,500.00

Description

Decor

Amount

500.00

Description

Food

Amount

22,500.00

Description

Contracted Services - music, photographer, etc.

Amount

2,500.00

Description

Recognition Awards

Amount	560.00
Description	Miscellaneous Expenses
Amount	1,000.00
TOTAL EXPENDITURES	27,060.00
TOTAL DEFICIT FOR PROJECT OR ORGANIZATION	5,440.00
Name of Organization	First State Community Action Agency, Inc.
Applicant/Authorized Official	Bernice M. Edwards
Date	10/17/2024
Affidavit Acknowledgement	Yes

If you feel this is not a valid submission please log into D3Forms to update this submissions status.
Please feel free to email clientservices@d3corp.com with any questions.

To Be Introduced: 10/29/24

Council District 4: Mr. Hudson
Tax I.D. No.: 134-19.00-25.00
911 Address: 34555 Central Avenue, Frankford

ORDINANCE NO. ____

AN ORDINANCE TO GRANT A CONDITIONAL USE OF LAND IN AN AR-1 AGRICULTURAL RESIDENTIAL DISTRICT FOR AN OFFICE AND STORAGE TO BE LOCATED ON A CERTAIN PORTION OF A PARCEL OF LAND LYING AND BEING IN BALTIMORE HUNDRED, SUSSEX COUNTY, CONTAINING 45.78 ACRES, MORE OR LESS

WHEREAS, on the 25th day of September 2024, a Conditional Use application, denominated Conditional Use No. 2555 was filed on behalf of Bittersweet Investments, LLC; and

WHEREAS, on the ____ day of _____ 2025, a public hearing was held, after notice, before the Planning and Zoning Commission of Sussex County and said Planning and Zoning Commission recommended that Conditional Use No. 2555 be _____; and

WHEREAS, on the ____ day of _____ 2025, a public hearing was held, after notice, before the County Council of Sussex County and the County Council of Sussex County determined, based on the findings of facts, that said conditional use is in accordance with the Comprehensive Development Plan and promotes the health, safety, morals, convenience, order, prosperity and welfare of the present and future inhabitants of Sussex County, and that the conditional use is for the general convenience and welfare of the inhabitants of Sussex County.

NOW, THEREFORE, THE COUNTY OF SUSSEX HEREBY ORDAINS:

Section 1. That Chapter 115, Article IV, Subsections 115-22, Code of Sussex County, be amended by adding the designation of Conditional Use No. 2555 as it applies to the property hereinafter described.

Section 2. The subject property is described as follows:

ALL that certain tract, piece, or parcel of land, lying and being situate in Baltimore Hundred, Sussex County, Delaware, and lying on the on the southeast corner of the intersection of Central Avenue (S.C.R. 84) and Old Church Cemetery Road (S.C.R. 367) and being more particularly described in the attached legal description prepared by James J. Gallagher, Esq. said parcel containing 45 acres, more or less.

This Ordinance shall take effect immediately upon its adoption by majority vote of all members of the County Council of Sussex County, Delaware.

To Be Introduced: 10/29/24

Council District 2: Mrs. Green
Tax I.D. No.: 235-19.00-11.00 & 11.01
911 Address: 14756 Twin Branch Road, Milton

ORDINANCE NO. ____

AN ORDINANCE TO GRANT A CONDITIONAL USE OF LAND IN AN AR-1 AGRICULTURAL RESIDENTIAL DISTRICT FOR A FARM WINERY WITH TASTING ROOM AND EVENTS VENUE TO BE LOCATED ON A CERTAIN PARCEL OF LAND LYING AND BEING IN BROAD KILL HUNDRED, SUSSEX COUNTY, CONTAINING 38.66 ACRES, MORE OR LESS

WHEREAS, on the 21st day of March 2024, a Conditional Use application, denominated Conditional Use No. 2520 was filed on behalf of Twin Branches, LLC and

WHEREAS, on the ____ day of _____ 2024, a public hearing was held, after notice, before the Planning and Zoning Commission of Sussex County and said Planning and Zoning Commission recommended that Conditional Use No. 2520 be _____; and

WHEREAS, on the ____ day of _____ 2025, a public hearing was held, after notice, before the County Council of Sussex County and the County Council of Sussex County determined, based on the findings of facts, that said conditional use is in accordance with the Comprehensive Development Plan and promotes the health, safety, morals, convenience, order, prosperity and welfare of the present and future inhabitants of Sussex County, and that the conditional use is for the general convenience and welfare of the inhabitants of Sussex County.

NOW, THEREFORE, THE COUNTY OF SUSSEX HEREBY ORDAINS:

Section 1. That Chapter 115, Article IV, Subsections 115-22, Code of Sussex County, be amended by adding the designation of Conditional Use No. 2520 as it applies to the property hereinafter described.

Section 2. The subject property is described as follows:

ALL that certain tract, piece, or parcel of land, lying and being situate in Broad Kill Hundred, Sussex County, Delaware, and lying on the west side of Twin Branch Road, approximately 0.89 mile south of the intersection of Saw Mill Road (S.C.R. 238) and Twin Branch Road, and being more particularly described in the attached legal description prepared by Young Conaway Stargatt & Taylor, LLP said parcel containing 38.66 acres, more or less.

This Ordinance shall take effect immediately upon its adoption by majority vote of all members of the County Council of Sussex County, Delaware.

To Be Introduced: 10/29/24

Council District 5: Mr. Rieley
Tax I.D. No.: 135-5.00-100.01
911 Address: 18206 McColleys Chapel Road, Georgetown

ORDINANCE NO. ____

AN ORDINANCE TO GRANT A CONDITIONAL USE OF LAND IN AN AR-1 AGRICULTURAL RESIDENTIAL DISTRICT FOR A LANDSCAPE BUSINESS TO BE LOCATED ON A CERTAIN PARCEL OF LAND LYING AND BEING IN GEORGETOWN HUNDRED, SUSSEX COUNTY, CONTAINING 5.04 ACRES, MORE OR LESS

WHEREAS, on the 11th day of December 2023, a Conditional Use application, denominated Conditional Use No. 2501 was filed on behalf of Jose Luis Vivar; and

WHEREAS, on the ____ day of _____ 2024, a public hearing was held, after notice, before the Planning and Zoning Commission of Sussex County, and said Planning and Zoning Commission recommended that Conditional Use No. 2501 be _____; and

WHEREAS, on the ____ day of _____ 2024, a public hearing was held, after notice, before the County Council of Sussex County and the County Council of Sussex County determined, based on the findings of facts, that said conditional use is in accordance with the Comprehensive Development Plan and promotes the health, safety, morals, convenience, order, prosperity and welfare of the present and future inhabitants of Sussex County, and that the conditional use is for the general convenience and welfare of the inhabitants of Sussex County.

NOW, THEREFORE, THE COUNTY OF SUSSEX HEREBY ORDAINS:

Section 1. That Chapter 115, Article IV, Subsections 115-22, Code of Sussex County, be amended by adding the designation of Conditional Use No. 2501 as it applies to the property hereinafter described.

Section 2. The subject property is described as follows:

ALL that certain tract, piece, or parcel of land, lying and being situate in Georgetown Hundred, Sussex County, Delaware, and lying on the west side of McColleys Chapel Road (S.C.R. 213), approximately 510 feet south of Deer Forest Road (S.C.R. 565), and being more particularly described in the attached legal description prepared by Hudson, Jones, Jaywork & Fisher said parcel containing 5.04 acres, more or less.

This Ordinance shall take effect immediately upon its adoption by majority vote of all members of the County Council of Sussex County, Delaware.

To Be Introduced: 10/29/24

Council District 1: Mr. Vincent
Tax I.D. No.: 132-6.00-303.00 (p/o)
911 Address: 27720 Oneals Road, Seaford

ORDINANCE NO. ____

AN ORDINANCE TO GRANT A CONDITIONAL USE OF LAND IN AN AR-1 AGRICULTURAL RESIDENTIAL DISTRICT FOR A SOLAR ARRAY TO BE LOCATED ON A PORTION OF A CERTAIN PARCEL OF LAND LYING AND BEING IN BROAD CREEK HUNDRED, SUSSEX COUNTY, CONTAINING 49.7 ACRES, MORE OR LESS

WHEREAS, on the 26th day of June 2023, a Conditional Use Application, denominated Conditional Use No. 2458 was filed on behalf of Oneals Solar, LLC; and

WHEREAS, on the ____ day of _____ 2024, a public hearing was held, after notice, before the Planning and Zoning Commission of Sussex County and said Planning and Zoning Commission recommended that Conditional Use No. 2458 be _____; and

WHEREAS, on the ____ day of _____ 2023, a public hearing was held, after notice, before the County Council of Sussex County and the County Council of Sussex County determined, based on the findings of facts, that said conditional use is in accordance with the Comprehensive Development Plan and promotes the health, safety, morals, convenience, order, prosperity and welfare of the present and future inhabitants of Sussex County, and that the conditional use is for the general convenience and welfare of the inhabitants of Sussex County.

NOW, THEREFORE, THE COUNTY OF SUSSEX HEREBY ORDAINS:

Section 1. That Chapter 115, Article IV, Subsection 115-22, Code of Sussex County, be amended by adding the designation of Conditional Use No. 2458 as it applies to the property hereinafter described.

Section 2. The subject property is described as follows:

ALL that certain tract, piece or parcels of land, lying and being situate in Broad Creek Hundred, Sussex County, Delaware, and lying on the north side of Oneals Road (S.C.R. 485) approximately 500 ft. southwest of Sussex Highway (Rt. 13), and being more particularly described in the attached legal description prepared by First American Title Insurance Company said parcel containing 49.7 acres, more or less.

This Ordinance shall take effect immediately upon its adoption by majority vote of all members of the County Council of Sussex County, Delaware.

To Be Introduced: 10/29/24

Council District 1: Mr. Vincent
Tax I.D. No.: 332-2.00-79.01
911 Address: 32120 Old Stage Rd., Laurel

ORDINANCE NO. ____

AN ORDINANCE TO GRANT A CONDITIONAL USE OF LAND IN AN AR-1 AGRICULTURAL RESIDENTIAL DISTRICT FOR THE EXTENSION OF EMPLOYEE PARKING, SELF-STORAGE, AND CONTAINER STORAGE TO BE LOCATED ON A CERTAIN PARCEL OF LAND LYING AND BEING IN LITTLE CREEK HUNDRED, SUSSEX COUNTY, CONTAINING 5.23 ACRES, MORE OR LESS

WHEREAS, on the 1st day of August 2024, a Conditional Use application, denominated Conditional Use No. 2544 was filed on behalf of Waste Management of Delaware, Inc.; and

WHEREAS, on the ____ day of _____ 2024, a public hearing was held, after notice, before the Planning and Zoning Commission of Sussex County and said Planning and Zoning Commission recommended that Conditional Use No. 2544 be _____; and

WHEREAS, on the ____ day of _____ 2024, a public hearing was held, after notice, before the County Council of Sussex County and the County Council of Sussex County determined, based on the findings of facts, that said conditional use is in accordance with the Comprehensive Development Plan and promotes the health, safety, morals, convenience, order, prosperity and welfare of the present and future inhabitants of Sussex County, and that the conditional use is for the general convenience and welfare of the inhabitants of Sussex County.

NOW, THEREFORE, THE COUNTY OF SUSSEX HEREBY ORDAINS:

Section 1. That Chapter 115, Article IV, Subsections 115-22, Code of Sussex County, be amended by adding the designation of Conditional Use No. 2544 as it applies to the property hereinafter described.

Section 2. The subject property is described as follows:

ALL that certain tract, piece, or parcel of land, lying and being situate in Little Creek Hundred, Sussex County, Delaware, and lying on the west side of Old Stage Road (S.C.R. 461) at the intersection of Old Stage Road (S.C.R. 461) and Trussum Pond Road (S.C.R. 462) and being more particularly described in the attached legal description prepared by Wendie C. Stabler, Esquire with Saul Ewing Arnstein & Lehr, LLP for said parcel containing 5.219 ac., more or less.

This Ordinance shall take effect immediately upon its adoption by majority vote of all members of the County Council of Sussex County, Delaware.

ENGINEERING DEPARTMENT

JOHN J. ASHMAN
DIRECTOR OF UTILITY PLANNING & DESIGN REVIEW

(302) 855-7370 T
(302) 854-5391 F
jashman@sussexcountyde.gov



Sussex County

DELAWARE
sussexcountyde.gov

MIKE HARMER, P.E.
SUSSEX COUNTY ENGINEER

Proposed Leeward Chase II Expansion of the Sussex County Unified Sanitary Sewer District

PUBLIC HEARING FACT SHEET

- Permission to post notices for a Public Hearing was granted on September 17, 2024, for an expansion of the Sussex County Unified Sanitary Sewer District (Airpark Area).
- The Engineering Department had received a request from Solutions IPEM on behalf of the owners of parcels 135-15.00-96.00 & 97.00, adjacent to the Leeward Chase project.
- The parcels contain an existing liquor store and an existing church. The parcels will be responsible for System Connection Charges of \$7,700.00 per EDU based on current rates.
- The Engineering Department added to the website, posted notices on October 10th, and advertised the weeks of 16th and 23rd.
- To date I have received no correspondence in support of opposition to this expansion.



COUNTY ADMINISTRATIVE OFFICES
2 THE CIRCLE | PO BOX 589
GEORGETOWN, DELAWARE 19947

SUSSEX COUNTY UNIFIED SANITARY SEWER DISTRICT
LEEWARD CHASE II EXPANSION
AFFIDAVIT FOR PUBLIC HEARING

STATE OF DELAWARE)(

COUNTY OF SUSSEX)(

BE IT REMEMBERED, That the subscriber, PHILLIP C. CALIO, personally appeared before me and known to me personally to be such, who being by me duly sworn to law did depose and say as follows:

- A. On October 10, 2024 he was a Utility Planner for the Sussex County Engineering Department, Sussex County, State of Delaware; and
- B. On October 10, 2024 he did post the attached "Public Notice," prepared by the Sussex County Engineering Department, at the following locations:
 - 1. On Delmarva Power Pole 53758/05365 in the southerly Right-of-Way (ROW) of Lewes-Georgetown Highway 651'± east of Charles Avenue,
 - 2. On DST Pole 20/17 in the southerly ROW of Lewes-Georgetown Highway 855'± east of Charles Avenue,
 - 3. On a post in the southerly ROW of Lewes-Georgetown Highway 1,005'± east of Charles Avenue,
 - 4. On DST Pole 19/16 in the southerly ROW of Lewes-Georgetown Highway, 1096'± east of Charles Avenue,
 - 5. On a post in front of a STOP sign at the intersection of Baltimore Avenue and Park Avenue, 4,677' southwest of Lewes-Georgetown Highway,
 - 6. On a post in front of a STOP sign at the intersection of Nanticoke Avenue and Park Avenue, 990' southwest of Springfield Road,
 - 7. On a post in front of a STOP sign at the intersection of Rudder Lane, Airport Road and Railroad Avenue,
 - 8. On a post in front of a STOP sign at the intersection of Rudder Lane & Airport Road

PHILLIP C. CALIO

SWORN TO AND SUBSCRIBED before me on this 14th day of Oct. A.D., 2024

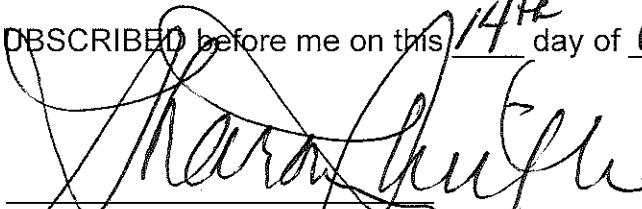
NOTARY PUBLIC



My Commission Expires 6/14/2026

PUBLIC NOTICE

PROPOSED LEEWARD CHASE II EXPANSION OF THE SUSSEX COUNTY UNIFIED SANITARY SEWER DISTRICT (AIRPARK AREA)

NOTICE IS HEREBY GIVEN that the Sussex County Council voted on **September 17, 2024**, to consider extending the boundary of the Sussex County Unified Sanitary Sewer District (SCUSSD), Airpark Area, to include parcels 135-15.00-96.00 & 97.00 located on Lewes Georgetown Highway, being situate in Georgetown Hundred, Sussex County, Delaware.

This action is in conformity with 9 Del.C §6502.

A description of the area, which is contiguous to and to be added to the SCUSSD is described as follows:

Beginning at a point, said point being on the SCUSSD (Airpark Area) boundary, said point being on the northwesternmost property corner of lands Now or Formerly (N/F) of SA SI INC, said point also being on the southerly Right-of-Way (ROW) of Lewes Georgetown Highway (Rt. 9); thence leaving said ROW and proceeding by and with said SCUSSD boundary and SA SI lands in a southeasterly and northeasterly direction respectively a distance of 386'± to a point, said point being on the southwesternmost property corner of lands N/F of Jehovah's Witness Congregation Georgetown DE; thence leaving said SA SI lands and proceeding by and with said Jehovah's Witness lands in a northeasterly and northwesterly direction respectively a total distance of 393'± to a point, said point being on the southerly ROW of Lewes Georgetown Highway (Rt. 9), thence proceeding by and with said ROW in a southwesterly direction a distance of 450'± to a point, said point being that of the **BEGINNING**.

NOTE: The above description has been prepared using Sussex County Tax Map 135-15.00 and Sussex County property assessment records. The annexation contains 2.00 acres more or less.

A map outlining and describing the extension of the SCUSSD is attached. The area involved is crosshatched.

The public hearing will be held on this issue at 1:30 p.m. on October 29, 2024 in the Sussex County Council Chambers, 2 The Circle, Georgetown, Delaware 19947. All interested persons, officials, residents, voters, taxpayers, property owners, or corporations in any way affected by this boundary extension are welcome to attend. There will be an opportunity for questions and answers. The Sussex County Council following the hearing, at one of their regularly scheduled meetings, will make the final decision on the boundary extension.

For further information, please call or write the Sussex County Engineering Department, 2 The Circle, Post Office Box 589, Georgetown, DE 19947 – (302) 855-7370.

Mike Harmer, P.E.
County Engineer

PROPOSED ANNEXATION Leeward Chase II

Existing SSD Area To Be Annexed



0 50 100 200
Feet

Map created: 9/23/2024



55.06

4.06 AC.

55.08

55.03

55

355.45

2.31 AC.

3.03 AC.

404

Route 9/404

250

55.05

250

400

200

100

100

100

55.07

100

200

50

200

250

200

100

100

92

95
1.00 Ac.

217.8

94

93

1472.10

200

97

1.00 Ac.

250

96

1.10 Ac.S

KINDOM HALL
JEVOHAH'S WITNESS

266.37

98.01

3.79 Ac.

160

The proposed annexation is scheduled to be discussed October 29, 2024 at 1:30 PM
in the Sussex County Council Chambers

For more information please visit: <https://sussexcountyde.gov/proposed-projects-schedules>
Or call Sussex County Utility Planning at 302-855-7370

RESOLUTION

A RESOLUTION TO EXTEND THE BOUNDARY OF THE SUSSEX COUNTY UNIFIED SANITARY SEWER DISTRICT (SCUSSD) DELAWARE COASTAL AIRPORT AREA, TO INCLUDE THE LEEWARD CHASE II AREA, ON THE SOUTH SIDE OF LEWES-GEORGETOWN HIGHWAY LOCATED IN THE GEORGETOWN HUNDRED, SUSSEX COUNTY, DELAWARE AND RECORDED IN THE OFFICE OF THE RECORDER OF DEEDS, IN AND FOR SUSSEX COUNTY, DELAWARE.

WHEREAS, Sussex County has established the Sussex County Unified Sanitary Sewer Sanitary Sewer District (SCUSSD); and

WHEREAS, in the best interests of the present district and to enhance the general health and welfare of that portion of Sussex County in the vicinity of Lewes-Georgetown Highway, the inclusion of this area will be beneficial; and

WHEREAS, in accordance with 9 Del.C., Section 6502 (a), the Sussex County Council may, upon request of the County Engineer, revise the boundary of an established sewer district when 50 or more houses have been connected by posting a public notice in four public places in the district describing the new or revised boundary; and

WHEREAS, the Sussex County Council has caused to be posted a public notice in at least four public places in the district, as verified by the affidavit of Phillip C. Calio, a copy of which affidavit and public notice is attached hereto and made a part hereof; and

WHEREAS, in accordance with 9 Del.C., Section 6502 (b), the Sussex County Council shall, within ninety days after posting the public notices pass a formal resolution establishing the new boundary of the district;

NOW, THEREFORE,

BE IT RESOLVED the Sussex County Council hereby revises the boundary of the SCUSSD to encompass the lands mentioned above in the Leeward Chase Subdivision area and further described as follows:

Beginning at a point, said point being on the SCUSSD (Airpark Area) boundary, said point being on the northwesternmost property corner of lands Now or Formerly (N/F) of SA SI INC, said point also being on the southerly Right-of-Way (ROW) of Lewes-Georgetown Highway (Rt. 9); thence leaving said ROW and proceeding by and with said SCUSSD boundary and SA SI lands in a southeasterly and northeasterly direction respectively a distance of 386'± to a point, said point being on the southwesternmost property corner of lands N/F of Jehovah's Witness Congregation Georgetown DE; thence

NOTE: The above description has been prepared using Sussex County Tax Map 135-15.00 and Sussex County property assessment records. The annexation contains 2.0 acres more or less.

A map outlining and describing the extension of the SCUSSD is attached. The area involved is highlighted.

BE IT FURTHER RESOLVED that the Sussex County Council directs the County Engineer and the Attorney for the County Council to procure the necessary lands and right-of-way by purchase, agreement, or condemnation in accordance with the existing statutes; and

BE IT FURTHER RESOLVED that the County Engineer is hereby authorized to prepare maps, plans, specifications, and estimates, let contracts for and supervise the construction and maintenance of, or enlarging and remodeling of, any and all structures required to provide for the safe disposal of sewage in the sanitary sewer district, as amended.

ENGINEERING DEPARTMENT

JOHN J. ASHMAN
DIRECTOR OF UTILITY PLANNING & DESIGN REVIEW

(302) 855-7370 T
(302) 854-5391 F
jashman@sussexcountype.gov



Sussex County

DELAWARE
sussexcountype.gov

MIKE HARMER, P.E.
SUSSEX COUNTY ENGINEER

**Proposed Woods at Angola Beach Expansion of the
Sussex County Unified Sanitary Sewer District**

PUBLIC HEARING FACT SHEET

- Permission to post notices for a Public Hearing was granted on September 17, 2024, for an expansion of the Sussex County Unified Sanitary Sewer District (Angola Neck Area).
- The Engineering Department had received a request from Mill Brook Engineering, LLC on behalf of their client, Hometown Angola Land, LLC owners of parcel 234-12.00-7.01, adjacent to the existing Angola Neck Area of the SCUSSD.
- This request is for one of the parcels of undeveloped land abutting the existing Angola Beach & Estates with (90) lots proposed for this project, with 74 on this parcel and 16 on parcel 7.02 which will flow to the existing private owned community system.
- The project will be responsible for System Connection Charges of \$7,700.00 per EDU based on current rates.
- The Engineering Department added to the website, posted notices on October 10th, and advertised the weeks of 16th and 23rd.
- To date I have received no correspondence in support of opposition to this expansion.



COUNTY ADMINISTRATIVE OFFICES
2 THE CIRCLE | PO BOX 589
GEORGETOWN, DELAWARE 19947

SUSSEX COUNTY UNIFIED SANITARY SEWER DISTRICT
WOODS AT ANGOLA BEACH EXPANSION
AFFIDAVIT FOR PUBLIC HEARING

STATE OF DELAWARE)(

COUNTY OF SUSSEX)(

BE IT REMEMBERED, That the subscriber, PHILLIP C. CALIO, personally appeared before me and known to me personally to be such, who being by me duly sworn to law did depose and say as follows:

- A. On October 10, 2024 he was a Utility Planner for the Sussex County Engineering Department, Sussex County, State of Delaware; and
- B. On October 10, 2024 he did post the attached "Public Notice," prepared by the Sussex County Engineering Department, at the following locations:
 - 1. On a post in front of a STOP sign @ the intersection of Suburban Blvd. and Angola Road,
 - 2. On a post in front of a stop sign @ the intersection of Angola Road and Angola Beach Road,
 - 3. On a post in front of a stop sign @ the intersection of Angola Road and Camp Arrowhead Road,
 - 4. On a post in front of stop sign @ the intersection of Angola Road and Middle Creek Blvd.,
 - 5. On the site of the annexation in the following 4 locations
 - a. On a post in the southerly ROW of Angola Road 76'± east of Suburban Blvd.,
 - b. On a post in the southerly ROW of Angola Road 510'± east of Suburban Blvd.,
 - c. On a post in the southerly ROW of Angola Road 154'± west of Bay Ridge Ln.,
 - d. On a post in the southerly ROW of Angola Road 102'± west of Kielbasa Ct.

PHILLIP C. CALIO

SWORN TO AND SUBSCRIBED before me on this 14th day of Oct. A.D., 2024

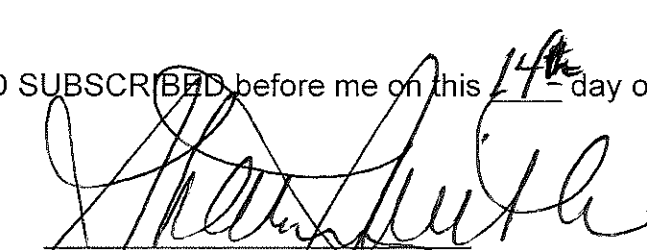
NOTARY PUBLIC

My Commission Expires 6/14/2026



PUBLIC NOTICE

PROPOSED WOODS AT ANGOLA BEACH EXPANSION OF THE SUSSEX COUNTY UNIFIED SANITARY SEWER DISTRICT (ANGOLA NORTH AREA)

NOTICE IS HEREBY GIVEN that the Sussex County Council voted on **September 17, 2024** to consider extending the boundary of the Sussex County Unified Sanitary Sewer District (SCUSSD), Angola North Area, to include the parcel 234-12.00-7.01 along Angola Road, being situate in Indian River Hundred, Sussex County, Delaware.

This action is in conformity with 9 Del.C §6502.

A description of the area, which is contiguous to and to be added to the SCUSSD is described as follows:

Beginning at a point formed by the southerly side of Angola Road with the westerly side of Angola Beach Road, thence along said Angola Beach Road, South 11°15'03" West, a distance of 655.13' to a point ; thence leaving said Angola Beach Road, North 82°11'17" West, a distance of 210.87' to a point ; thence by a curve to the right having a radius of 275.00' an arc distance of 1.51' to a point ; thence North 78°44'57" West, a distance of 129.83' to a point ; thence South 11°15'03" West, a distance of 183.00' to a point; thence North 78°44'57" West, a distance of 88.25' to a point; thence North 46°44'38" West, a distance of 240.49' to a point; thence South 43°15'22" West, a distance of 123.00' to a point; thence North 46°44'38" West, a distance of 31.88' to a point; thence South 43°15'22" West, a distance of 193.89' to a point; thence by a curve to the left having a radius of 182.00' an arc distance of 370.39' to a point; thence along a curve to the left having a radius of 295.00' an arc distance of 240.26' to a point ; thence by a curve to the left having a radius of 652.00' an arc distance of 161.99' to a point; thence North 36°16'29" West, a distance of 183.87' to a point; thence by a curve to the right having a radius of 325.00' an arc distance of 481.75' to a point; thence North 48°39'21" East a distance of 11.52' to a point; thence North 41°20'39" West, a distance of 50.00' to a point; thence South 48°39'21" West, a distance of 21.33' to a point; thence North 28°18'59" West, a distance of 116.76' to a point; thence by a curve to the right having a radius of 126.00' an arc distance of 96.24' to a point; thence North 15°26'46" East, a distance of 395.44' to a point; thence along the said Angola Road, by a curve to the right having a radius of 6,885.96' an arc distance of 201.99' to a point; thence continuing along the same, South 76°44'38" East, a distance of 1353.25' to a point, said point **being that of the BEGINNING**

NOTE: The above descriptions have been prepared using Sussex County Tax Map 234-12.00 and Sussex County property assessment records. The annexation contains 31.17 acres more or less.

A map outlining and describing the extension of the SCUSSD is attached. The area involved is crosshatched.

The public hearing will be held on this issue at 1:30 P.m. on October 29, 2024, in the Sussex County Council Chambers, 2 The Circle, Georgetown, Delaware 19947. All interested persons, officials, residents, voters, taxpayers, property owners, or corporations in any way affected by this boundary extension are welcome to attend. There will be an opportunity for questions and answers. The Sussex County Council following the hearing, at one of their regularly scheduled meetings, will make the final decision on the boundary extension.

For further information, please call or write the Sussex County Engineering Department, 2 The Circle, Post Office Box 589, Georgetown, DE 19947 – (302) 855-1299).

Mike Harmer, P.E.
County Engineer

PROPOSED ANNEXATION Woods At Angola Beach

Existing SSD TMP 234-12.00-7.01

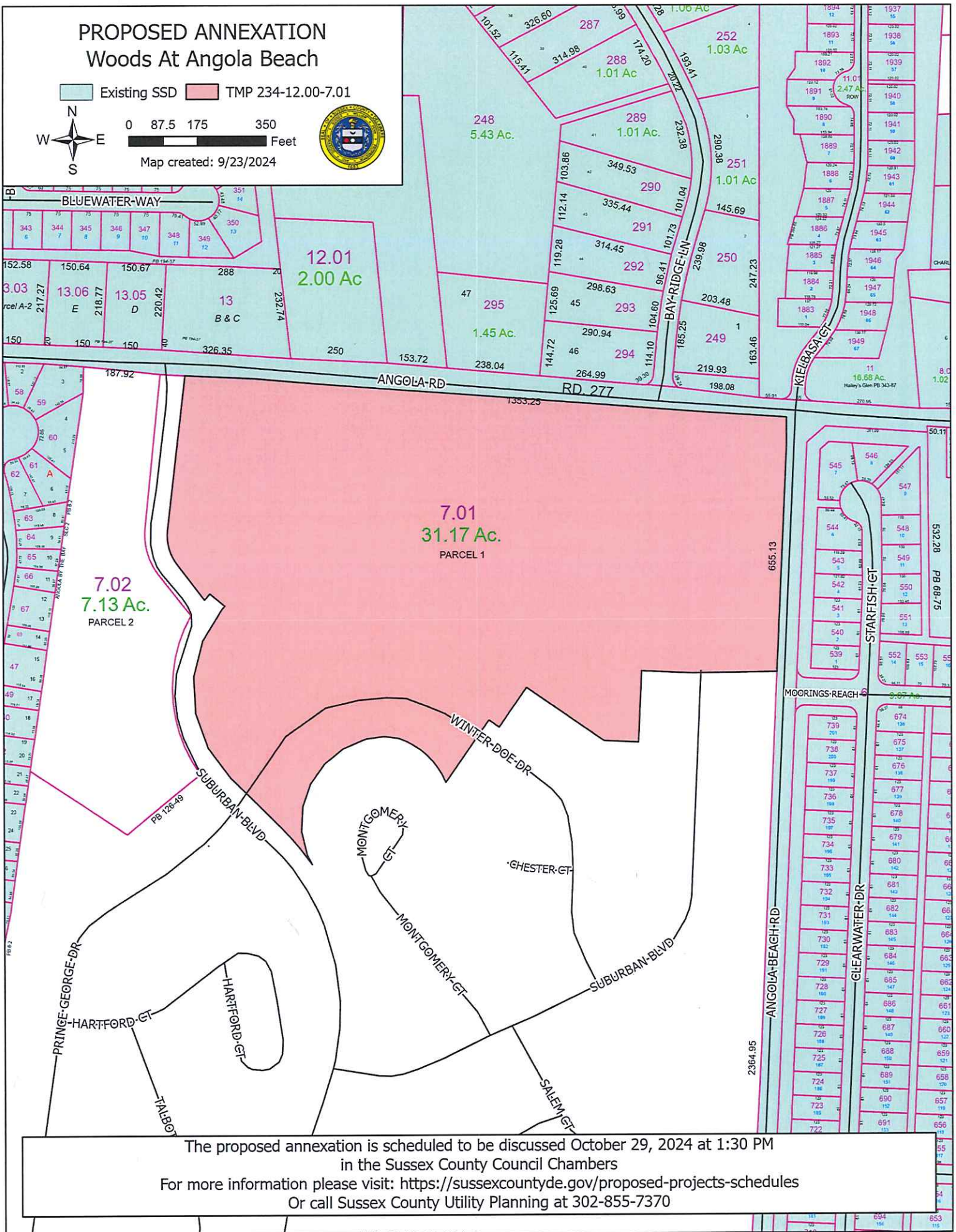
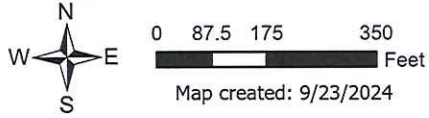

The proposed annexation is scheduled to be discussed October 29, 2024 at 1:30 PM
in the Sussex County Council Chambers
For more information please visit: <https://sussexcountyde.gov/proposed-projects-schedules>
Or call Sussex County Utility Planning at 302-855-7370

RESOLUTION

A RESOLUTION TO EXTEND THE BOUNDARY OF THE SUSSEX COUNTY UNIFIED SANITARY SEWER DISTRICT (SCUSSD) ANGOLA NECK AREA, TO INCLUDE THE WOODS AT ANGOLA BEACH AREA, ON THE SOUTH SIDE OF ANGOLA ROAD LOCATED IN THE INDIAN RIVER HUNDRED, SUSSEX COUNTY, DELAWARE AND RECORDED IN THE OFFICE OF THE RECORDER OF DEEDS, IN AND FOR SUSSEX COUNTY, DELAWARE.

WHEREAS, Sussex County has established the Sussex County Unified Sanitary Sewer Sanitary Sewer District (SCUSSD); and

WHEREAS, in the best interests of the present district and to enhance the general health and welfare of that portion of Sussex County in the vicinity of Camp Arrowhead, the inclusion of this area will be beneficial; and

WHEREAS, in accordance with 9 Del.C., Section 6502 (a), the Sussex County Council may, upon request of the County Engineer, revise the boundary of an established sewer district when 50 or more houses have been connected by posting a public notice in four public places in the district describing the new or revised boundary; and

WHEREAS, the Sussex County Council has caused to be posted a public notice in at least four public places in the district, as verified by the affidavit of Phillip C. Calio, a copy of which affidavit and public notice is attached hereto and made a part hereof; and

WHEREAS, in accordance with 9 Del.C., Section 6502 (b), the Sussex County Council shall, within ninety days after posting the public notices pass a formal resolution establishing the new boundary of the district;

NOW, THEREFORE,

BE IT RESOLVED the Sussex County Council hereby revises the boundary of the SCUSSD to encompass the lands mentioned above in the Camp Arrowhead II area and further described as follows:

Beginning at a point formed by the southerly side of Angola Road with the westerly side of Angola Beach Road, thence along said Angola Beach Road, South 11°15'03" West, a distance of 655.13' to a point ; thence leaving said Angola Beach Road, North 82°11'17" West, a distance of 210.87' to a point ; thence by a curve to the right having a radius of 275.00' an arc distance of 1.51' to a point ; thence North 78°44'57" West, a distance of 129.83' to a point ; thence South 11°15'03" West, a distance of 183.00' to a point; thence North 78°44'57" West, a distance of 88.25' to a point; thence North 46°44'38" West, a distance of 240.49' to a point; thence South 43°15'22" West, a distance of 123.00' to a point; thence North 46°44'38" West, a distance of 31.88' to a point; thence South 43°15'22" West, a distance of 193.89' to a point; thence by a curve to the left having a radius of 182.00' an arc distance of 370.39' to a point; thence along a curve to the left having a radius of 295.00' an arc distance of 240.26' to a point ; thence by a curve to the left having a radius of 652.00' an arc distance of 161.99' to a point; thence North 36°16'29" West, a distance of 183.87' to a point; thence by a curve to the right having a radius of 325.00' an arc distance of 481.75' to a point; thence North 48°39'21" East a distance of 11.52' to a point; thence North 41°20'39" West, a distance of 50.00' to a point; thence South 48°39'21" West, a distance of 21.33' to a point; thence North 28°18'59" West, a distance of 116.76' to a point; thence by a curve to the right having a radius of 126.00' an arc distance of 96.24' to a point; thence North

15°26'46" East, a distance of 395.44' to a point; thence along the said Angola Road, by a curve to the right having a radius of 6,885.96' an arc distance of 201.99' to a point; thence continuing along the same, South 76°44'38" East, a distance of 1353.25' to a point, said point **being that of the BEGINNING**

NOTE: The above description has been prepared using Sussex County Tax Map 234-12.00 and Sussex County property assessment records. The annexation contains 31.17 acres more or less.

A map outlining and describing the extension of the SCUSSD is attached. The area involved is crosshatched and highlighted.

BE IT FURTHER RESOLVED that the Sussex County Council directs the County Engineer and the Attorney for the County Council to procure the necessary lands and right-of-way by purchase, agreement, or condemnation in accordance with the existing statutes; and

BE IT FURTHER RESOLVED that the County Engineer is hereby authorized to prepare maps, plans, specifications, and estimates, let contracts for and supervise the construction and maintenance of, or enlarging and remodeling of, any and all structures required to provide for the safe disposal of sewage in the sanitary sewer district, as amended.



Memorandum

To: Sussex County Council
The Honorable Michael H. Vincent
The Honorable Cynthia C. Green
The Honorable Douglas B. Hudson
The Honorable John L. Rieley
The Honorable Mark G. Schaeffer

From: Jamie Whitehouse, AICP, Director of Planning & Zoning

CC: Everett Moore, County Attorney

Date: October 25, 2024

RE: County Council Report for C/U 2523 filed on behalf of Tayra Trinidad

The Planning and Zoning Department received an application (C/U 2523 filed on behalf of Tayra Trinidad) for a nail salon business, to be located in an AR-1 Agricultural Residential Zoning District at Tax Parcel 134-11.00-219.03. The property is located at 32379 Powell Farm Road, Frankford. The parcel size is 0.55 ac. +/-

The Planning & Zoning Commission held a Public Hearing on the application on September 25, 2024. At the meeting of September 25, 2024, the Planning & Zoning Commission recommended approval of the application for the 5 reasons stated and subject to the 10 recommended conditions as outlined within the motion (copied below).

Below are the minutes from the Planning & Zoning Commission meetings of September 25, 2024.

Minutes of the September 25, 2024, Planning & Zoning Commission Meeting

C/U 2523 Tayra Trinidad

AN ORDINANCE TO GRANT A CONDITIONAL USE OF LAND IN AN AR-1 AGRICULTURAL RESIDENTIAL DISTRICT FOR A NAIL SALON BUSINESS TO BE LOCATED ON A CERTAIN PARCEL OF LAND LYING AND BEING IN BALTIMORE HUNDRED, SUSSEX COUNTY, CONTAINING 0.55 ACRE, MORE OR LESS. The property is lying on the east side of Powell Farm Road (S.C.R. 365), approximately 384 feet north of Burbage Road (S.C.R. 353). 911 Address: 32379 Powell Farm Road, Frankford. Tax Map Parcel: 134-11.00-219.03. Zoning: AR-1 (Agricultural Residential District).



Mr. Whitehouse advised the Commission that submitted into the record were a copy of the staff analysis, a copy of the DelDOT SLER, a copy of a letter received from the Sussex County Engineering Department Utility Planning Division, and zero comments.

Ms. Tayra Trinidad, the applicant spoke on behalf of herself that she has owned the business at this location for three years now and is looking to expand: that she is looking to add one employee and another manicure/pedicure station; that she is currently under the home occupation classification and needs to apply for the Conditional Use in order to have more than one employee.

Ms. Wingate asked about the parking on the property and the number of clients that would be present at one time. The concern is that on the site plan provided it appeared that there was a disposal field on the area that cars would be parked and that could be an issue down the line.

Ms. Trinidad informed the Commission that they have a septic and well and that the parking would not be on the disposal field.

The Commission asked if she would like a lighted sign and what the hours of operation would be.

Ms. Trinidad stated that she would like a lighted sign, and the hours of operation would be Monday through Friday 9:00AM -7:00PM in the summer, Monday through Friday 9:00AM-6:00PM in the winter and Saturdays 9:00AM – 5:00PM year-round.

Mr. Whitehouse stated for the record that the property does not have County Sewer and is on a septic.

Upon there being no further questions Chairman Wheatley closed the public hearing.

At the conclusion of the public hearing, the Commission discussed the Application.

Mr. Mears requested that Mr. Roberston read the motion on his behalf.

Mr. Mears moved the Commission to recommend **APPROVAL** of **C/U 2523 Tayra Trinidad** for a nail salon business based upon the record made at the public hearing and for the following reasons:

1. The site is located within the Coastal Area according to the Sussex County Comprehensive Plan. This small business use is appropriate within this area.
2. This area is zoned AR-1 Agricultural Residential. The use of the property as a small nail salon business that was just the applicant as a home occupation. The Applicant seeks to expand the use to include an additional employee. A conditional use for this relatively inconspicuous business is appropriate at this location.
3. The use will not adversely affect area roadways or neighboring properties with the conditions imposed with this Conditional Use.
4. A small nail salon provides a service at a convenient location to nearby Sussex County residents, and it has a public or semi-public character that will benefit residents of Sussex County.
5. No parties appeared in opposition to this application.
6. This recommendation is subject to the following conditions:

- A. This use shall be limited to nail salon business.

- B. There shall be not more than 2 manicure stations and 2 pedicure stations. The Final Site Plan shall depict the area of the existing structure set aside for the business use and this floorplan shall show the locations of the stations.
- C. There shall only be retail sales occurring from the site that coincide with scheduled appointments of clients, not general retailing.
- D. There shall be one lighted sign, not to exceed 32 square feet per side.
- E. The hours of operation shall be limited to 9:00 am through 7:00 pm, Monday through Friday, and 9:00 am through 5:00 pm on Saturdays. There shall be no Sunday hours.
- F. Any lighting on the site shall be screened so that it does not shine on neighboring properties or roadways.
- G. The applicant shall comply with all DelDOT requirements, including any entrance or roadway improvements.
- H. The Final Site Plan shall clearly show all areas for employee and customer vehicle parking, and these areas shall be clearly marked on the site itself. There shall not be any parking within the property's setbacks.
- I. Failure to comply with any of these conditions may be grounds for termination of the Conditional Use approval.
- J. The Final Site Plan shall be subject to the review and approval of the Sussex County Planning and Zoning Commission.

Motion by Mr. Mears, seconded by Ms. Wingate and carried unanimously to recommend approval of **C/U 2523 Tayra Trinidad** for the reasons and the conditions stated in the motion. Motion carried 4 -0.

Vote by roll call: Mr. Mears – yea, Ms. Wingate – yea, Mr. Collins – yea, Chairman Wheatley – yea

PLANNING & ZONING COMMISSION

ROBERT C. WHEATLEY, CHAIRMAN
HOLLY J. WINGATE, VICE-CHAIRMAN
SCOTT COLLINS
J. BRUCE MEARS
BRIAN BUTLER



Sussex County

DELAWARE
sussexcountyde.gov
302-855-7878 T

JAMIE WHITEHOUSE, MRTPI, AICP
DIRECTOR OF PLANNING & ZONING

PLANNING AND ZONING AND COUNTY COUNCIL INFORMATION SHEET

Planning Commission Public Hearing Date: September 25th, 2024

County Council Public Hearing Date: October 29th, 2024

Application: C/U 2523 Tayra Trinidad

Applicant: Ms. Tayra Trinidad
32379 Powell Farm Road
Frankford, DE 19945

Owner: Mr. Arturo Granados-Gonzalez
31883 New Street
Dagsboro, DE 19939

Site Location: The property is lying on the east side of Powell Farm Road (S.C.R. 365), approximately 384 feet north of Burbage Road (S.C.R. 353) at 32379 Powell Farm Road in Frankford, Delaware.

Current Zoning: Agricultural Residential (AR-1) District

Proposed Use: To allow for a two (2) chair nail salon within an Agricultural Residential (AR-1) District.

Comprehensive Land Use Plan Reference: Coastal Area

Councilmanic District: District 4 – Mr. Hudson

School District: Indian River School District

Fire District: District 84 - Millville Fire Department

TID: Not w/in any established Transportation Improvement Districts.

Sewer: Sussex County

Water: N/A

Site Area: 0.55 acres +/-

Tax Map ID.: 134-11.00-219.03



JAMIE WHITEHOUSE, AICP MRTPI
PLANNING & ZONING DIRECTOR
(302) 855-7878 T
(302) 854-5079 F
jamie.whitehouse@sussexcountyde.gov



Sussex County

DELAWARE
sussexcountyde.gov

Memorandum

To: Sussex County Planning Commission Members
From: Ms. Lauren DeVore, AICP, Planner III
CC: Mr. Vince Robertson, Assistant County Attorney and Applicant
Date: September 18th, 2024
RE: Staff Analysis for C/U 2523 Tayra Trinidad

This memo is to provide background and analysis for the Planning Commission to consider as a part of Application C/U 2523 Tayra Trinidad to be reviewed during the September 25th, 2024, Planning Commission Meeting. This analysis should be included in the record of this Application and is subject to comments and information that may be presented during the Public Hearing.

Please note that the following Staff Analysis is for informational purposes only and does not prejudice any decision that the Sussex County Planning & Zoning Commission or Sussex County Council may wish to make as part of any Application submitted to the Department.

Tax Parcel ID: 134-11.00-219.03

Proposal: The request is for a Conditional Use for Tax Parcel 134-11.00-219.03 to allow for a two (2) chair nail salon to be located within an Agricultural Residential (AR-1) District. The Parcel consists of 0.55 acres +/- and is located at 32379 Powell Farm Road in Frankford, Delaware.

Zoning: The Parcel is zoned Agricultural Residential (AR-1) District. The adjacent Parcels to the north, south and east of the subject Parcel also have a zoning of Agricultural Residential (AR-1) District). The Parcels located immediately west of the subject property on the opposite side of Powell Farm Road (S.C.R. 365) are zoned General Residential (GR) District.

Future Land Use Map Designation w/in Comprehensive Plan: The subject property is located within the "Coastal Area" as outlined in the Sussex County's 2018 Comprehensive Plan.

Applicability to Comprehensive Plan: The 2018 Sussex County Comprehensive Plan Update (Comprehensive Plan) provides a framework of how land is to be developed. As part of the Comprehensive Plan, a Future Land Use Map is included to help determine how land should be zoned to ensure responsible and thoughtful development. The Future Land Use Map in the Plan indicates that the subject property has a Growth Area Future Land Use designation of "Coastal Area." All surrounding Parcels to the north, south, east and west contain a Growth Area Future Land Use designation of "Coastal Area."

As outlined in the 2018 Sussex County Comprehensive Plan Update, "Coastal Areas" are "considered Growth Areas, the County encourages only appropriate forms of concentrated new development in these areas, especially when environmental features are in play" (2018 Sussex County Comprehensive Plan, 4-9). Furthermore, the Plan notes that "Coastal Areas" are "areas that can accommodate development provided special environmental concerns are addressed." and



that “mixed-use development should also be allowed [where,] in doing so, careful mixtures of homes with light commercial and institutional uses can be appropriate to provide for convenient services and to allow people to work close to home” (2018 Sussex County Comprehensive Plan, 4-15 & 16).

Table 4.5-2 “Zoning Districts Applicable to Future Land Use Categories” in the 2018 Sussex County Comprehensive Plan notes that the existing Agricultural Residential (AR-1) District is an applicable Zoning District within the “Coastal Area” Future Land Use Map Designation (2018 Sussex County Comprehensive Plan, 4-25).

Further Site Considerations:

- **Density:** N/A
- **Open Space Provisions:** N/A
- **Agricultural Areas:** Staff note that the Site is located within the vicinity of lands that appear to be actively farmed.
- **Interconnectivity:** N/A
- **Transportation Improvement District (TID):** The Parcel is not located within any established Transportation Improvement Districts.

Staff further note that the Delaware Department of Transportation (DelDOT) has indicated in their Service Level Evaluation Response (SLER) that the development’s traffic impact is anticipated to be “diminutive” in the context of the “Sussex County/Delaware Department of Transportation Memorandum of Understanding (MOU) for Land Development Coordination.”

- **Forested Areas:** N/A
- **Wetlands Buffers/Waterways:** The County’s Online Mapping System does not indicate areas of any wetlands or wetland areas on the property.
- **Other Site Considerations (ie: Flood Zones, Tax Ditches, Groundwater Recharge Potential, etc.):** The property is located within Flood Zone “X” – Areas determined to
- be outside the 1% annual chance flood and outside the 500-year floodplain. DNREC’s Flood Planning Tool notes that the property is located within the Indian River Bay Watershed and the White Creek-Indian River Bay Subwatershed. The Flood Planning Tool also notes that the approximate Ground Elevation Height at the Parcel is 15-ft.

Staff note that the property lies within the St. Georges Tax Ditch Area, but that the property does not appear to contain any Tax Ditches or tax ditch Rights-Of-Way (ROW).

The property is located within an area of “poor” Groundwater Recharge Potential. The property is not located within any Wellhead Protection Areas.

Existing Conditional Uses within the Vicinity of the Subject Site: A Data Table and Supplemental Map have been supplied which provide further background regarding the approval status of Applications in the area, including the location of all other Conditional Use Applications that are within a 1-mile distance from the subject site.

Since 1970, there have been 27 Conditional Use Applications within a 1-mile radius of the Application Site of which 23 Applications were approved by the Sussex County Council and 1 Application was denied.

Conditional Use Number	APPLICANT	Tax Parcel #	Current Zoning	Proposed Use	P&Z Decision	P&Z Decision Date	CC Decision Date	CC Decision	Ordinance Number
2166	Deborah Townsend	134-11.00-226.01	AR-1	Professional office and business services with	Recommended Approval	4/11/2019	4/30/2019	Approved	2651
1518	Atlantic Auction Co., Inc.	134-11.00-227.00	AR-1	self storage & professional	Recommended Approval	1/22/2004	1/27/2004	Approved	1660
144	DeMarie	134-11.00-76.00	MR	manufactured home park	N/A	N/A	N/A	Withdrawn	N/A
1405	Michael G. McCarthy	134-11.00-808.02	AR-1	offices & woodshop	Recommended Denial	5/17/2001	6/19/2001	Approved	1473
1588	Leroy & JoAnn Marvel	134-15.00-24.00	AR-1	small engine repair	Recommended Approval	2/10/2005	3/15/2005	Approved	1760
1327	Frank Cochran	134-15.00-23.00	AR-1	lawn mower repair & boat	Recommended Denial	2/24/2000	3/21/2000	Approved	1369
1828	Mark & Dawn Theriault	134-11.00-189.00	AR-1	boat/rv storage	Recommended Approval	4/22/2010	5/11/2010	Approved	2118
1289	Dorothy A. Theriault	134-11.00-187.00	AR-1	antique collectible gift shop	Recommended Approval	6/10/1999	6/29/1999	Approved	1322
1985	Eugenia Athan	134-15.00-118.00	AR-1/MR	Storage Facility	Recommended Approval	4/10/2014	5/20/2014	Approved	2350
1323	Theodore B. Simpler	134-15.00-9.04	AR-1	office for surveying firm	Recommended Approval	1/12/2000	2/1/2000	Approved	1362
221	Louis DeMarie	134-11.00-595.00	GR	mobile home sales office	N/A	N/A	N/A	Approved	N/A
830	Trustees of St. Georges United Methodist Church	134-11.00-106.00	AR-1	addition to existing cemetery	Recommended Approval	8/15/1985	9/3/1985	Approved	295
1621	Gregory & Patricia White	134-11.00-107.00	MR	multi-family	Recommended Denial	10/13/2005	11/29/2005	Denied	N/A
267	Raymond Mitchell	134-11.00-155.00	AR-1	additional bay on non-conforming business	N/A	N/A	N/A	Approved	N/A
2255	John Sommers	134-15.00-95.03	AR-1	Bicycle sales, repair, storage	Recommended Approval	8/26/2021	9/14/2021	Approved	2798
1298	Lawrence & Susan Kelly	134-15.00-95.00	AR-1	nursery/landscaping/garden	Recommended Approval	7/22/1999	8/10/1999	Approved	1335
1692	Millville Vol. Fire Co., Inc.	134-11.00-105.00	MR	fire co. substation	Recommended Approval	7/13/2006	8/1/2006	Approved	1866
1969	Melvin L. Joseph Construction Co.	134-11.00-207.00	AR-1	Borrow Pit	Recommended Approval	10/10/2013	10/15/2013	Approved	2324
332	Hogsten	134-11.00-216.00	AR-1	campground	N/A	N/A	N/A	Denied	N/A
1536	Mr. Natural Bottled Water	134-15.00-95.02	AR-1	office/warehouse	Recommended Approval	4/29/2004	5/18/2004	Approved	1692
2196	Wine Worx, LLC	134-11.00-53.00	AR-1	AMENDMENTS TO CONDITIONS OF APPROVAL FOR CONDITIONAL USE NO. 2127	Recommended Approval	11/14/2019	12/17/2019	Approved	2696
70	James & Marie Hogsten	134-11.00-216.00	AR-1	Camping Area	N/A	N/A	8/29/1972	Approved	N/A
221	Louis DeMarie	134-11.00-595.00	GR	Mobile Home Sales Office	N/A	N/A	7/16/1974	Approved	N/A
414	R Dwight Crevision, Jr.	134-11.00-187.00	AR-1	sales of camper tops, pick up caps & repair parts	N/A	N/A	5/17/1977	Approved	N/A
1900	Doris D. Turner	134-11.00-207.00	AR-1	Borrow Pit	Withdrawn	6/2/2011	6/2/2011	Withdrawn	N/A
2127	Wine Worx, LLC	134-11.00-53.00	AR-1	Event Venue	Recommended Approval	5/24/2018	9/25/2018	Approved	2600
2437	James R. Powell	134-15.00-19.02	AR-1	RV & Boat Storage	N/A	N/A	N/A	N/A	N/A



The screenshot displays the Sussex County GIS web application interface. The top navigation bar includes 'Layers', 'Search', 'Basemaps', 'Select Area', 'Eagleview', and 'Print'. The left sidebar shows a 'Layers' panel with categories like 'Neighborhood Business', 'Business Community Distr', 'Business Research', 'Conditional Use', and '2019 Future Land Use'. The main map area shows a residential street grid with various colored overlays representing different zoning and land use designations. A specific parcel is highlighted in orange. On the right side, a 'Selected Features' panel shows the details for parcel 134-11.00-219.03.

Selected Features (1)	
BOOK	5193
PAGE	134
FULLNAME	GONZALEZ ARTURO GRANADOS
Second_Owner_Name	MARIA DEL CARMEN RIVERA
MAILINGADDRESS	31883 NEW STREET
CITY	DAGSBORO
STATE	DE
a_account	
DESCRIPTION	E/RD 365
DESCRIPTION2	304' N/RD 353
DESCRIPTION3	LOT 2
LUC	999
SCHOOL	
MUNI	00
CAP	0
APRBLDG	29600
APRLAND	5000
PINWASSEMNTUNIT	134-11.00-219.03
PIN	134-11.00-219.03

Based on the analysis of the land use, surrounding zoning and uses, a Conditional Use Application to allow for a two (2) chair nail salon, subject to considerations of scale and impact, could be considered as being consistent with the land use, area zoning and surrounding uses.



C/U 2523 - Tayra Trinidad
Aerial Map
TM# 134-11.00-219.03

 Tax Parcels
 Tax Parcels



 Feet



Introduced: 8/27/24

Council District 4: Mr. Hudson
Tax I.D. No.: 134-11.00-219.03
911 Address: 32379 Powell Farm Road, Frankford

ORDINANCE NO. ____

AN ORDINANCE TO GRANT A CONDITIONAL USE OF LAND IN AN AR-1 AGRICULTURAL RESIDENTIAL DISTRICT FOR A NAIL SALON BUSINESS TO BE LOCATED ON A CERTAIN PARCEL OF LAND LYING AND BEING IN BALTIMORE HUNDRED, SUSSEX COUNTY, CONTAINING 0.55 ACRE, MORE OR LESS

WHEREAS, on the 1st day of April 2024, a Conditional Use application, denominated Conditional Use No. 2523 was filed on behalf of Tayra Trinidad; and

WHEREAS, on the ____ day of _____ 2024, a public hearing was held, after notice, before the Planning and Zoning Commission of Sussex County, and said Planning and Zoning Commission recommended that Conditional Use No. 2523 be _____; and

WHEREAS, on the ____ day of _____ 2024, a public hearing was held, after notice, before the County Council of Sussex County and the County Council of Sussex County determined, based on the findings of facts, that said conditional use is in accordance with the Comprehensive Development Plan and promotes the health, safety, morals, convenience, order, prosperity and welfare of the present and future inhabitants of Sussex County, and that the conditional use is for the general convenience and welfare of the inhabitants of Sussex County.

NOW, THEREFORE, THE COUNTY OF SUSSEX HEREBY ORDAINS:

Section 1. That Chapter 115, Article IV, Subsections 115-22, Code of Sussex County, be amended by adding the designation of Conditional Use No. 2523 as it applies to the property hereinafter described.

Section 2. The subject property is described as follows:

ALL that certain tract, piece, or parcel of land, lying and being situate in Baltimore Hundred, Sussex County, Delaware, and lying on the east side of Powell Farm Road (S.C.R. 365), approximately 384 feet north of Burbage Road (S.C.R. 353), and being more particularly described in the attached legal description prepared by Stephen P. Ellis Law Firm, LLC said parcel containing 0.55 acre, more or less.

This Ordinance shall take effect immediately upon its adoption by majority vote of all members of the County Council of Sussex County, Delaware.



Memorandum

To: Sussex County Council
The Honorable Michael H. Vincent
The Honorable Cynthia C. Green
The Honorable Douglas B. Hudson
The Honorable John L. Rieley
The Honorable Mark G. Schaeffer

From: Jamie Whitehouse, AICP, Director of Planning & Zoning

CC: Everett Moore, County Attorney

Date: October 25, 2024

RE: County Council Report for C/Z 2018 filed on behalf of James Yerkie, II

The Planning and Zoning Department received an application (C/Z 2018 filed on behalf of James Yerkie, II) for a Change of Zone for Tax Parcel 130-3.00-170.04 from an MR Medium Density Residential Zoning District, to an AR-1 Agricultural Residential Zoning District. The property is located on the east side of Old Shawnee Road (SCR 619) approximately 0.35 mile northeast of Shawnee Road (Rt. 36). The parcel size is 1.53 acres +/-

The Planning & Zoning Commission held a Public Hearing on the application on September 25, 2024. At the meeting of September 25, 2024, the Planning & Zoning Commission defer action on the application, leaving the record open to enable a Public Hearing to be scheduled for the associated Conditional Use application (Reference C/U 2464).

Below are the minutes from the Planning & Zoning Commission meeting of September 25, 2024

Minutes of the September 25, 2024, Planning & Zoning Commission Meeting

C/Z 2018 James Yerkie, II

AN ORDINANCE TO AMEND THE COMPREHENSIVE ZONING MAP OF SUSSEX COUNTY FROM AN MR MEDIUM RESIDENTIAL DISTRICT TO AN AR-1 AGRICULTURAL RESIDENTIAL DISTRICT FOR A CERTAIN PARCEL OF LAND LYING AND BEING IN CEDAR CREEK HUNDRED, SUSSEX COUNTY, CONTAINING 1.53 ACRES, MORE OR LESS. The property is lying on the east side of Old Shawnee Road (S.C.R. 619) approximately 0.35-mile northeast of Shawnee Road (Rt. 36). 911 Address: N/A. Tax Map Parcels: 130-3.00-170.04. Zoning: MR (Medium Density Residential District).



Mr. Whitehouse advised the Commission that submitted into the record were a copy of the staff analysis, a copy of the DelDOT SLER, a copy of a letter received from the Sussex County Engineering Department Utility Planning Division, and one letter in opposition.

Mr. James Yerkie, II, the applicant, spoke on behalf of himself that he owns a piece of land that he wants to build his home on and also have his heating and air conditioning business located out of the land that is currently zoned as MR and he needs to change to AR-1 in order to live on the property and run his business from there; that currently he has 2 storage containers on the property that he is using for storage of materials and cars; that in order to come into compliance with the violations for the storage containers he needs to go through the Change of Zone and then the Conditional Use application.

Mr. Whitehouse informed the Commission that the property is currently zoned MR and he was violated by the Constables for having the storage containers on undeveloped land; that in order to meet compliance with the code, he would need to get a Conditional Use for the property, however that cannot happen until this Change in Zone takes place; that once this application is completed and if it is approved, then he will come back before the Commission for his Conditional Use application which will allow for the storage containers to be on the property.

Ms. Patricia Marshall of 6470 Old Shawnee Rd, spoke in opposition to the application that she does not want to live across from a business and she has lived in this area and never had anything but residential properties surrounding her.

Ms. Sally Marshall, spoke in opposition to the application that the applicant is not being clear as to what he is trying to do with the property; that he states he wants to build his forever home on the property, but yet has the storage containers with not only materials for his business but also vehicles in and around the storage containers with for sale signs on them.

Upon there being no further questions Chairman Wheatley closed the public hearing.

At the conclusion of the public hearing, the Commission discussed the Application.

In relation to **C/Z 2018 James Yerkie, II**. Motion by Mr. Mears to defer action for further consideration, leaving the record open pending the completion of the Conditional Use hearing, seconded by Ms. Wingate and carried unanimously. Motion carried 4-0.

PLANNING & ZONING COMMISSION

ROBERT C. WHEATLEY, CHAIRMAN
HOLLY J. WINGATE, VICE-CHAIRMAN
SCOTT COLLINS
J. BRUCE MEARS
BRIAN BUTLER



Sussex County

DELAWARE
sussexcountyde.gov
302-855-7878 T
302-854-5079 F
JAMIE WHITEHOUSE, MRTPI, AICP
DIRECTOR OF PLANNING & ZONING

PLANNING AND ZONING AND COUNTY COUNCIL INFORMATION SHEET
Planning Commission Public Hearing Date: September 25, 2024

Application: CZ 2018 James Yerkie II

Applicant: James Yerkie II
10 Delaware Avenue
Milford, DE 19963

Owner: James Yerkie II
10 Delaware Avenue
Milford, DE 19963

Site Location: Located on the east side of Old Shawnee Road (Rt. 619), approximately 0.40-mile(s) northeast of the intersection of Old Shawnee Road and Shawnee Road (Rt. 36).

Current Zoning: Medium Residential (MR) Zoning District

Proposed Zoning: Agricultural Residential (AR-1) Zoning District

Comprehensive Land Use Plan Reference: Developing Area

Councilmanic District: Ms. Green

School District: Milford School District

Fire District: Milford Fire Co.

Sewer: On-site septic

Water: On-site well

Site Area: 1.53-acres +/-

Tax Map ID.: 130-3.00-170.04



JAMIE WHITEHOUSE, AICP MRTPI
PLANNING & ZONING DIRECTOR
(302) 855-7878 T
jamie.whitehouse@sussexcountyde.gov



Sussex County

DELAWARE
sussexcountyde.gov

Memorandum

To: Sussex County Planning and Zoning Commission Members
From: Ann Lepore, Planner I
CC: Mr. Vince Robertson, Assistant County Attorney and Applicant
Date: September 18, 2024
RE: Staff Analysis for CZ 2018 James Yerkie II

The purpose of this memo is to provide background and analysis for the Planning and Zoning Commission to consider as a part of Application CZ 2018 (James Yerkie II) to be reviewed the September 25th, 2024, Planning and Zoning Commission Meeting. This analysis should be included in the record of this application and is subject to comments and information that may be presented during the public hearing.

The request is for a Conditional Use for Tax Parcel: 130-3.00-170.04 to allow for a change of zone from a Medium-Density Residential (MR) zoning district to an Agricultural Residential (AR-1) zoning district. The property is lying on the east side of Old Shawnee Road (Rt. 619), approximately 0.40-mile(s) northeast of the intersection of Old Shawnee Road and Shawnee Road (Rt. 36). The applicant is applying for 1.53-acre(s) +/- to be included in the Change of Zone application.

Comprehensive Plan Analysis

The 2018 Sussex County Comprehensive Plan Update (Comprehensive Plan) provides a framework of how land is to be developed. As part of the Comprehensive Plan, a Future Land Use Map is included to help determine how land should be zoned to ensure responsible development. The Future Land Use Map in the plan indicates that the parcel has a designation of “Developing Area.” All adjoining parcels to the north, south, east, and west across Old Shawnee Road also have a Future Land Use Map designation of “Developing Area.”

As outlined within the 2018 Sussex County Comprehensive Plan, The Developing Areas are newer, emerging growth areas that demonstrate the characteristics of developmental trends. Most of the proposed Developing Areas are adjacent to municipalities, within or adjacent to potential future annexation areas of a municipality, or adjacent to Town Centers. – A range of housing types are appropriate in Developing Areas, including single family homes, townhouses, and multi-family units. In selected areas and at appropriate intersections, commercial uses should be allowed. A variety of office uses would be appropriate in many areas. Portions of the Developing Areas with good road access and few nearby homes should allow for business and industrial parks. Appropriate mixed-use development should also be allowed. In doing so, careful mixtures of homes with light commercial and institutional uses can be appropriate to provide for convenient services and to allow people to work close to home (Sussex County Comprehensive Plan, 4-14).



Zoning Information

The subject property is zoned Medium-Density Residential (MR) District. All adjacent properties to the north, east, south, and west across Old Shawnee Road are also zoned Medium-Density Residential (MR) District.

Table 4.5-2 “Zoning Districts Applicable to Future Land Use Categories” in the 2018 Sussex County Comprehensive Plan notes that the Medium-Density Residential District as well as the proposed zoning of Agricultural Residential (AR-1) are applicable Zoning Districts within the “Developing Area” Future Land Use Map Designation.

Existing Conditional Uses within the Vicinity of the Subject Property

Since 2011, there have been zero (0) Change of Zone applications within a one (1) mile radius of the Application Site.



Site Considerations

- **Density:** N/A
- **Open Space Provisions:** N/A

- **Agricultural Areas:** The subject parcel currently adjoins parcels that are actively used for agricultural purposes.
- **Interconnectivity:** N/A
- **Transportation Improvement District (TID):** N/A
- **Forested Areas:** N/A
- **Wetlands Buffers/Waterways:** N/A
- **Other Site Considerations (ie: Flood Zones, Tax Ditches, Groundwater Recharge Potential, etc.):** Parcel is located within the “X” Flood Zone. The parcel is located within an area of fair groundwater recharge.

Based on the analysis provided, the application to allow for a change of zone from a Medium-Density Residential (MR) zoning district to an Agricultural Residential (AR-1) zoning district in this location could be considered as being consistent with the surrounding land use, zoning, and uses, subject to considerations of scale and impact.

Sussex County

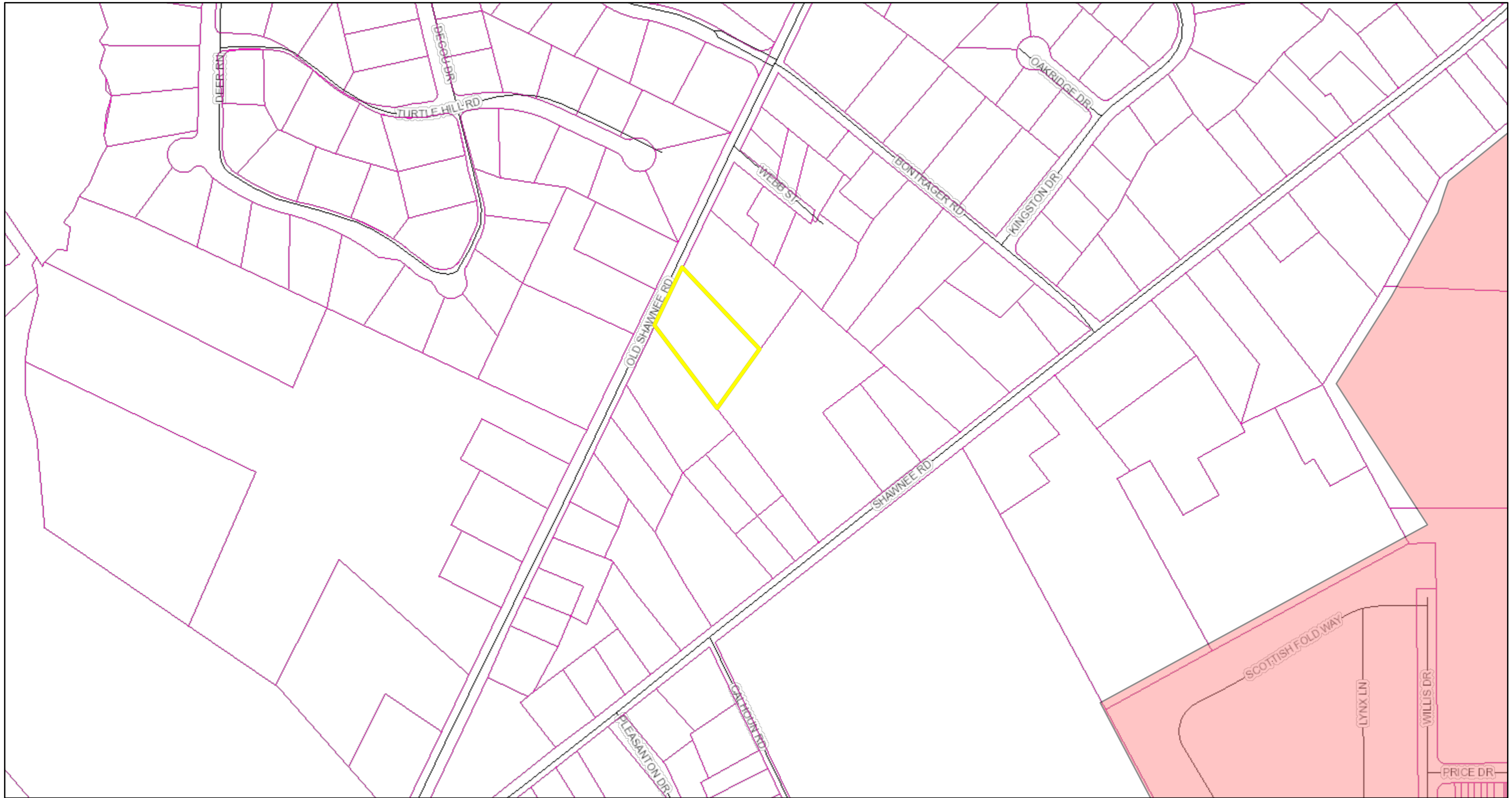

October 31, 2023

polygonLayer

Override 1

Override 2

Municipal Boundaries

Tax Parcels

Streets

County Boundaries

DOE School Districts

layer51

Red: Band_1

Green: Band_2

Blue: Band_3

1:4,514

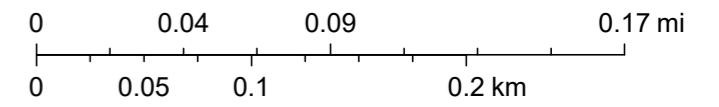

Delaware Department of Education, Wetland mapping is supported with funding provided by the Environmental Protection Agency, FEMA, DNREC, Division of Watershed Stewardship, Drainage Program, john.inkster@state.de.us, Sussex County, Sussex County Government

Sussex County

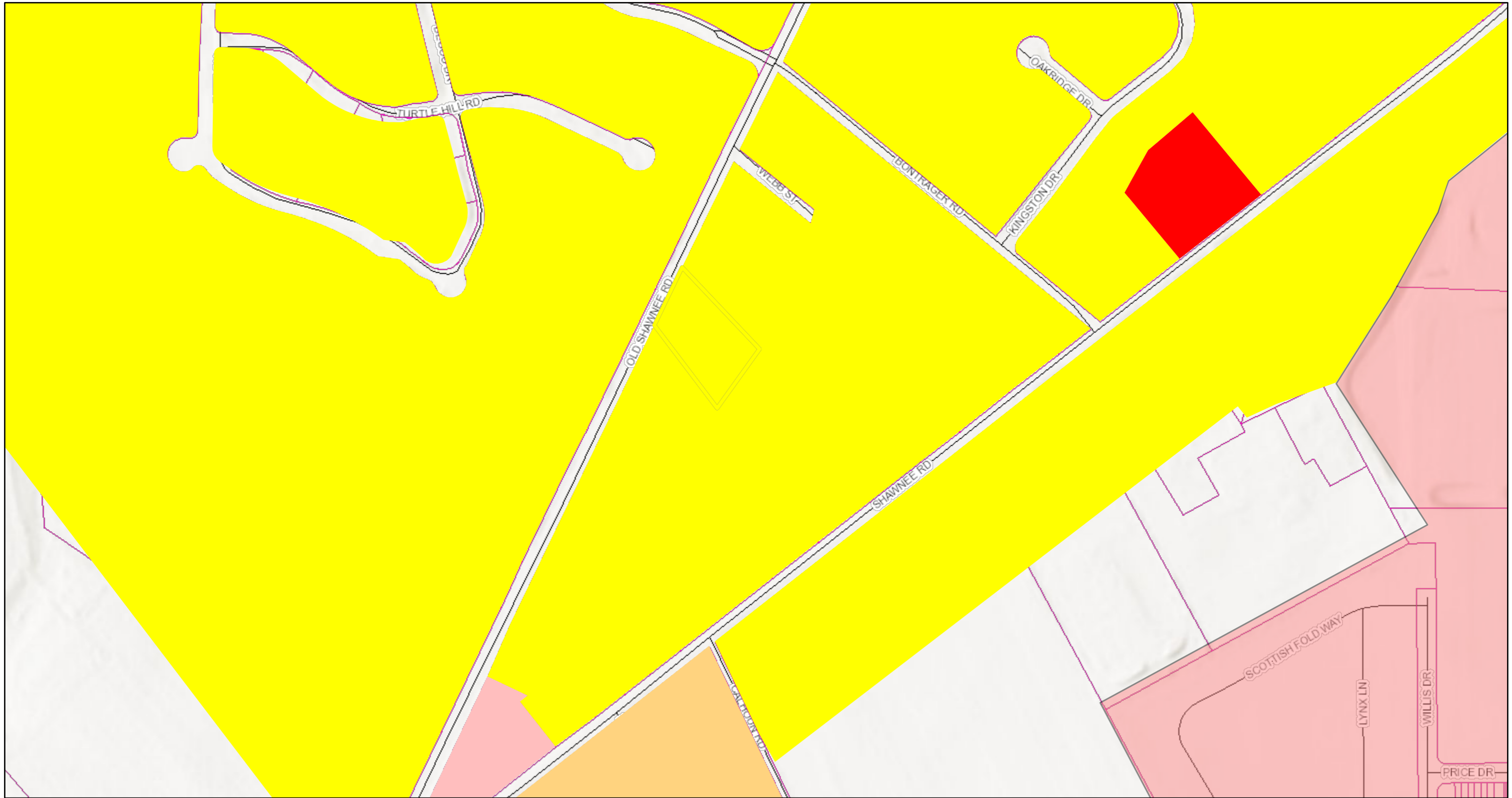

October 31, 2023

polygonLayer

Override 1

Override 2

Zoning

Medium Residential - MR

General Residential - GR

Neighborhood Business - B-1

General Commercial - C-1

Municipal Boundaries

Tax Parcels

Streets

County Boundaries

DOE School Districts

layer50

Red: Band_1

Green: Band_2

Blue: Band_3

World Hillshade

1:4,514

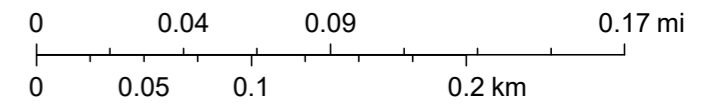

Delaware Department of Education, Wetland mapping is supported with funding provided by the Environmental Protection Agency, FEMA, DNREC, Division of Watershed Stewardship, Drainage Program, john.inkster@state.de.us, Sussex County, Sources: Esri, Airbus DS, USGS, NGA, NASA, CGIAR, N Robinson, NCEAS, NLS,

Sussex County

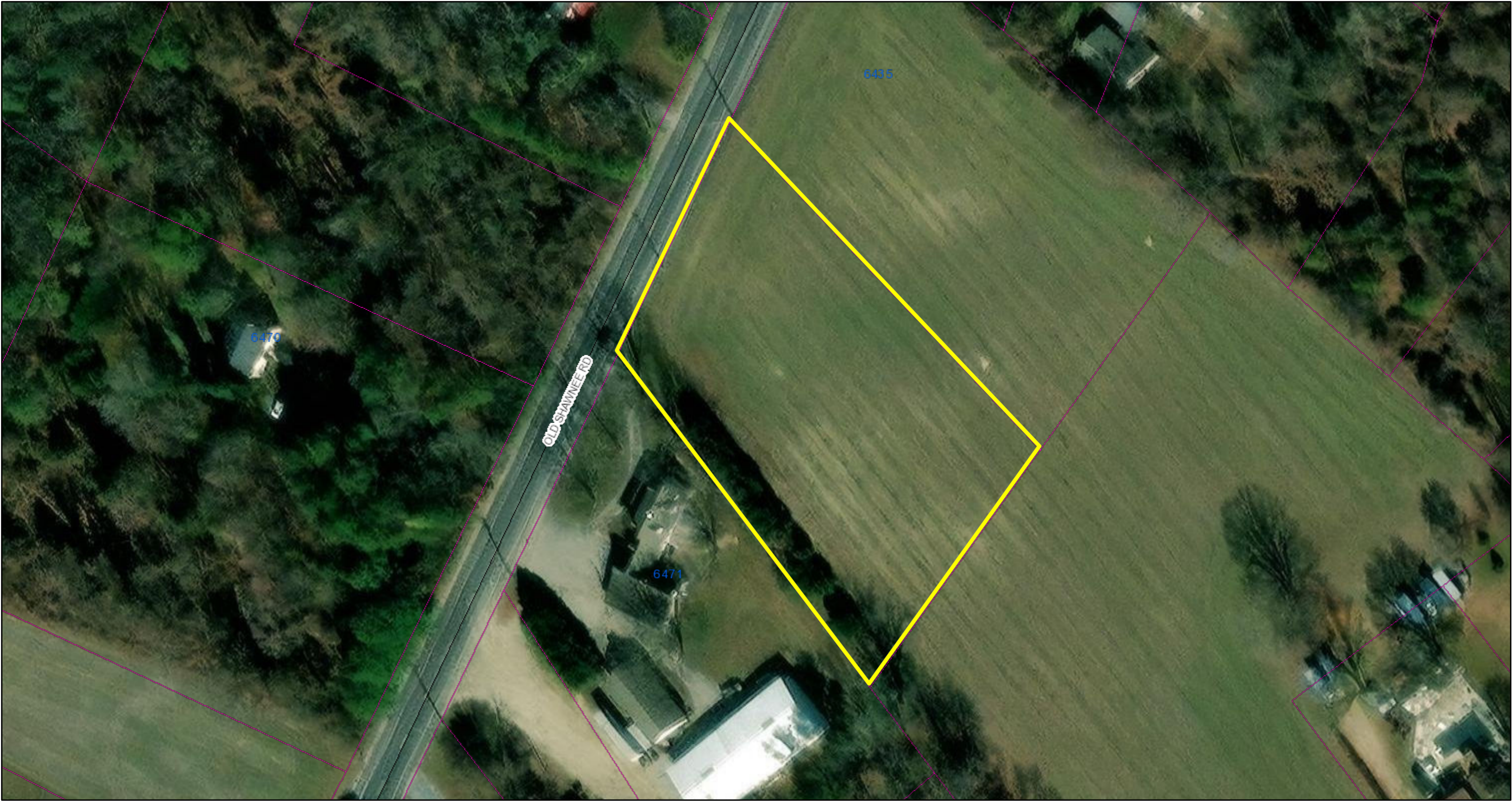

October 31, 2023

- | | |
|---|---|
| <p>polygonLayer</p> <ul style="list-style-type: none"> Override 1 Override 2 Tax Parcels | <p>911 Address</p> <ul style="list-style-type: none"> Streets County Boundaries DOE School Districts |
|---|---|

- World Imagery
- Low Resolution 15m Imagery
- High Resolution 60cm Imagery
- High Resolution 30cm Imagery

- Citations
- 30cm Resolution Metadata

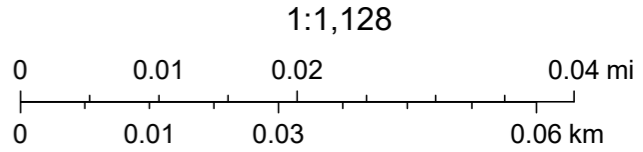

Delaware Department of Education, Wetland mapping is supported with funding provided by the Environmental Protection Agency, Maxar, Microsoft, FEMA, DNREC, Division of Watershed Stewardship, Drainage Program, john.inkster@state.de.us, Sussex County, Sussex County Government

Introduced: 8/27/24

Council District 2: Mrs. Green

Tax I.D. No.: 130-3.00-170.04

911 Address: N/A

ORDINANCE NO. ____

AN ORDINANCE TO AMEND THE COMPREHENSIVE ZONING MAP OF SUSSEX COUNTY FROM AN MR MEDIUM RESIDENTIAL DISTRICT TO AN AR-1 AGRICULTURAL RESIDENTIAL DISTRICT FOR A CERTAIN PARCEL OF LAND LYING AND BEING IN CEDAR CREEK HUNDRED, SUSSEX COUNTY, CONTAINING 1.53 ACRES, MORE OR LESS

WHEREAS, on the 13th day of July 2023, a zoning application, denominated Change of Zone No. 2018 was filed on behalf of James Yerkie, II; and

WHEREAS, on the ____ day of _____ 2023, a public hearing was held, after notice, before the Planning and Zoning Commission of Sussex County and said Planning and Zoning Commission recommended that Change of Zone No. 2018 be _____; and

WHEREAS, on the ____ day of _____ 2023, a public hearing was held, after notice, before the County Council of Sussex County and the County Council of Sussex County has determined, based on the findings of facts, that said change of zone is in accordance with the Comprehensive Development Plan and promotes the health, safety, morals, convenience, order, prosperity and welfare of the present and future inhabitants of Sussex County,

NOW, THEREFORE, THE COUNTY OF SUSSEX HEREBY ORDAINS:

Section 1. That Chapter 115, Article II, Subsection 115-7, Code of Sussex County, be amended by deleting from the Comprehensive Zoning Map of Sussex County the zoning classification of [MR Medium Residential District] and adding in lieu thereof the designation AR-1 Agricultural Residential District as it applies to the property hereinafter described.

Section 2. The subject property is described as follows:

ALL that certain tract, piece, or parcel of land, lying and being situate in Cedar Creek Hundred, Sussex County, Delaware, and lying on the east side of Old Shawnee Road (S.C.R. 619) approximately 0.35 mile northeast of Shawnee Road (Rt. 36) and being more particularly described in the attached legal description prepared by Walter G. Feindt, P.A., said parcel containing 1.53 acres, more or less.

This Ordinance shall take effect immediately upon its adoption by majority vote of all members of the County Council of Sussex County, Delaware.



Memorandum

To: Sussex County Council
The Honorable Michael H. Vincent
The Honorable Cynthia C. Green
The Honorable Douglas B. Hudson
The Honorable John L. Rieley
The Honorable Mark G. Schaeffer

From: Jamie Whitehouse, AICP, Director of Planning & Zoning

CC: Everett Moore, County Attorney

Date: October 25, 2024

RE: County Council Report for Ord. 23-01 (23-12) in Relation to the Potential Amendment of the Sewer Tier Map of the Comprehensive Plan

On August 30, 2023, the Sussex County Planning & Zoning Department received a request to consider a potential amendment of the Sewer Tier Map of the Comprehensive Plan in relation to Tax Parcels 433-11.00-17.00 and 17.01. The parcels are located at 34910 & 33913 Delaware Avenue, Frankford.

The County Council introduced the Ordinance at its meeting on September 17, 2024.

The Planning & Zoning Commission held a Public Hearing on the application on September 25, 2024. At the meeting of September 25, 2024, the Planning & Zoning Commission recommended adoption of the Ordinance for the reasons as outlined in the motion (copied below)

Below are the minutes from the Planning & Zoning Commission meeting of September 25, 2024

Minutes of the September 25, 2024, Planning & Zoning Commission Meeting

Ord. 23-01 (23-12) Sewer Tier Amendment

AN ORDINANCE TO AMEND THE SUSSEX COUNTY SEWER TIER MAP OF THE COMPREHENSIVE PLAN FROM THE TIER 4 AREA (SYSTEM OPTIONAL AREAS) TO THE TIER 2 (SUSSEX COUNTY PLANNING AREA) IN RELATION TO TAX PARCELS 433-11.00-17.00 and 433-11.00-17.01. The properties are lying on the east side of Dupont Boulevard (Route 113) on the north and south sides of Delaware Avenue (S.C.R. 54A), at the intersection of Dupont Boulevard (Route 113) and Delaware Avenue (S.C.R. 54A). 911 Addresses: 34910 & 33913 Delaware Avenue, Frankford. Tax Map Parcels: 433-11.00-17.00 & 17.01. Zoning: C-1 (General Commercial District).



Mr. Whitehouse advised the Commission that submitted into the record were a copy of the ordinance as it was introduced to County Council on September 17th, a copy of a sewer plan that's been received, a copy of the PLUS comments that have been received in the State Planning Office, a copy of a letter that has been received from the Sussex County Engineering Department Utility Planning Division and zero comments. To provide some background, it's a little bit different in that this is a request to amend an element of the comprehensive plan and it's specifically requesting to just amend the sewer tier map element of the plan. That because of that, it has to be reported to the states PLUS process for PLUS review for the State of Delaware, and we've received those comments, and they are in the packet. This was not initiated by staff, but by a private landowner who then submitted to the county.

The Commission discussed the Ordinance and stated that technically the County is the applicant and a public hearing must be had to inform the public as to what is happening; that the Sewer Tier Map helps with planning for new infrastructure; that the Engineering Department has forecasted what's going to be and where and then provides guidance via the Sewer Tier Map as to what properties will be serviced by County Engineering or private facilities.

Mr. Ray Blakeney of Plitko Engineering, spoke on behalf the property owner Mr. Travis Martin, who owns an existing business since 2006 on the property and currently it has a septic holding tank on site that serves both parcels and he wants to gain access to sewer; that it's better for his business and the environment; that both parcels are adjacent to the Tier 1 Sussex County Unified Sewer District and they're requesting the amendment to change the classification to Tier 2 as part of their efforts to be annexed.

Mr. Wesley Hayes of 34598 Delaware Ave. Frankford, stated that he wants to see the sewer plan that they are trying to implement for clarity as he owns adjacent properties to Mr. Martin and does not understand why they are trying to do what they are saying; that Mr. Martin currently has some buildings that are connected to sewer and he wants to know what the plan is for this case as he doesn't understand the plan; that if they are going to do connections for sewer that he is concerned about the traffic and trucks on Delaware Ave during the construction process; that the road is not wide enough to handle that kind of increase in traffic.

Chairman Wheatley stated that the request today is to take the property into a Tier 2 on the Sewer Tier Map and then to a Tier 1; that there will be multiple public hearings before the final change would be made to ultimately construct the sewer connection; that this is only the first step and once this goes through and if it is approved by County Council, then it will have to come back through the process again to go from Tier 2 to Tier 1; that once it gets through that process then there will be discussion on engineering and construction.

The Commission gave Mr. Hayes a copy of the plan that has been submitted at this time and offered for the Planning & Zoning staff to sit with him so he can understand what it all means.

Upon there being no further questions Chairman Wheatley closed the public hearing.

At the conclusion of the public hearing, the Commission discussed the Application.

Mr. Mears requested that Mr. Roberston read the motion on his behalf.

Mr. Mears moved the Commission to recommend County Council **ADOPT Ord. 23-12 Sewer Tier Amendment** based upon the record made at the public hearing and for the following reasons:

This is an Ordinance to Amend the County Sewer Tier Map of the Comprehensive Plan from the Tier 4 area, which is system operational areas to the Tier 2 Area, which is Sussex County planning area in relation to tax parcels 433-11.00-17.00 and 433-11.00-17.01. The properties are lying on the east side of DuPont Blvd. (Route 113) and on the North and South side of Delaware Ave., (C.R. 54 A) at the intersection of DuPont Blvd. (Route 113) and Delaware Avenue again, (C.R. 54 A). 911 address is 34910 and 33913 Delaware Ave. Frankford. Tax map parcels are 433-11.00-17.00 and 17.01. The zoning is C1, General Commercial district, and the motion is that the Commission moved to recommend this ordinance based upon the record made during the public hearing and with the concurrence of the County Engineering Department for the map amendment. This will enable the property, which has been used for business purposes, to connect to county sewer. This property is adjacent to Tier 1, and this change to Tier 2 will enable it to be annexed into the Sussex County Sanitary Sewer District, so moved.

Motion by Mr. Mears, seconded by Ms. Wingate and carried unanimously to recommend County Council adopt Ord. 23-12 for the reasons and the conditions stated in the motion. Motion carried 4 - 0.

Vote by roll call: Mr. Mears – yea, Ms. Wingate – yea, Mr. Collins – yea, Chairman Wheatley – yea

ORDINANCE NO. _____

AN ORDINANCE TO AMEND THE SUSSEX COUNTY SEWER TIER MAP OF THE COMPREHENSIVE PLAN IN RELATION TO TAX PARCELS 433-11.00-17.00 & 17.01

WHEREAS, on August 30th, 2022, the Sussex County Planning and Zoning Office received an Application for a requested Comprehensive Plan Amendment to amend the Sussex County Sewer Tier Map element of the Comprehensive Plan to change the Sewer Tier designation of Sussex County Parcel Nos. 433-11.00-17.00 and 17.01; and

WHEREAS, the Parcels comprise 0.96 acres of land, more or less, lying and being within Dagsboro Hundred, and are located on the west side of Dupont Boulevard (Route 113) on the north and south sides of Delaware Avenue (S.C.R. 54A), at the intersection of Dupont Boulevard (Route 113) and Delaware Avenue (S.C.R. 54A);

WHEREAS, The Properties are designated as being within the Tier 4 – System Optional Areas (Parcel #17.00) and undesignated (Parcel #17.01) as set forth in the Sussex County Sewer Tier Map as Figure 7.3-2 in the 2018 Comprehensive Plan for Sussex County;

WHEREAS, the Parcels contains the Future Land Use Map designation of Developing Area as set forth in the Sussex County 2045 Future Land Use Map identified as Figure 4.5-1 of the Sussex County Comprehensive Plan; and

WHEREAS, as noted in the Sussex County Comprehensive Plan, central sewer facilities are “strongly encouraged” within the Developing Area; and

WHEREAS, Sussex County Council desires to adopt this Ordinance amending the Sussex County Sewer Tier Map element of the Plan with minor amendments; and

WHEREAS, in accordance with the required process for public hearings on Ordinances such as this one, both the Sussex County Planning & Zoning Commission and the Sussex County Council will hold public hearings on this Ordinance but limited in scope to this specific proposed Amendment to the Sussex County Sewer Tier Map contained in the Plan.

NOW, THEREFORE, THE COUNTY OF SUSSEX HEREBY ORDAINS:

Section 1. The Sussex County Sewer Tier Map identified as Figure 7.3-2 of the Sussex County Comprehensive Plan is hereby amended to change the Parcels currently classified as Tier 4 – System Optional Areas for Sussex County Parcel No. 433-11.00-17.00 and currently unclassified for Sussex County Parcel No. 433-11.00-17.01 from the Tier 4 - System Optional Areas Sewer Tier designation and unclassified designation to the Tier 2 – Sussex County Planning Area designation; Sussex County Parcel Nos. 433-11.00-17.00 and 17.01 so changed as identified in Exhibit A, attached hereto and incorporated herein.

Section 2. This Ordinance shall also take effect following its adoption by majority vote of all members of the County Council of Sussex County, Delaware, and upon certification by the State of Delaware.



State of Delaware, Maxar, Microsoft, VITA, Esri, HERE, Garmin, IPC

Ord 23-12
Sewer Tier Amendment - T Martin
TM# 433-11.00-17.00, 17.02

 **Ord 23-12 Travis Martin**

N



 Feet
0 25 50 100





VITA, Delaware FirstMap, Esri, HERE, Garmin, INCREMENT P, NGA, USGS

Ord 23-12
Sewer Tier Amendment - T Martin
Street Map
TM# 433-11.00-17.00, 17.02

 **Ord 23-12 Travis Martin**

N



0 175 350 700 Feet





Maxar, Microsoft, VITA, Esri, HERE, Garmin, IPC

Ord 23-12
Sewer Tier Amendment - T Martin
TM# 433-11.00-17.00, 17.02

-  Ord 23-12 Travis Martin
-  Ord 23-12 - Mailing List Parcels

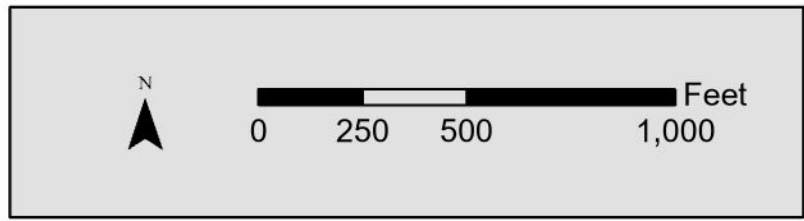
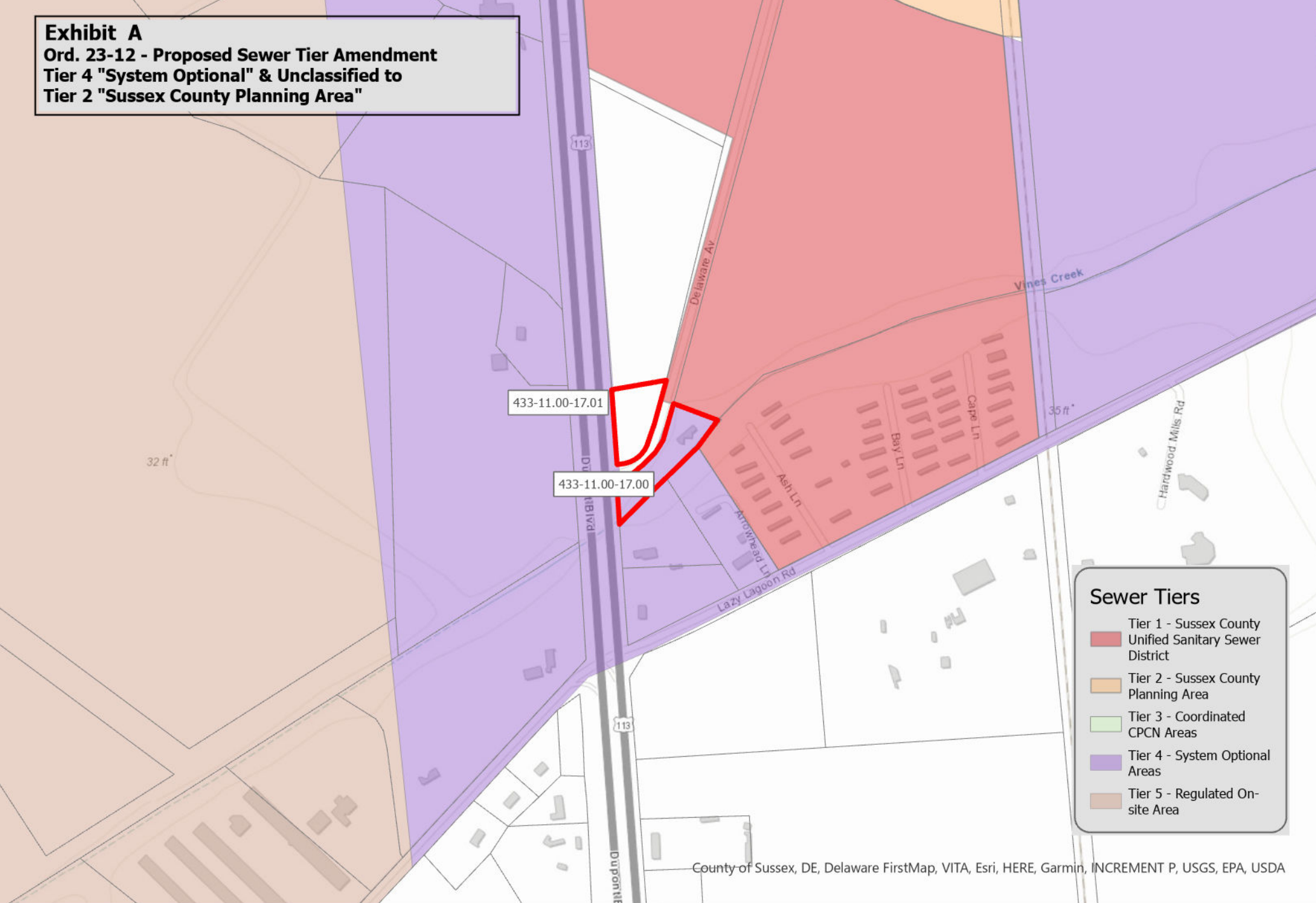

Exhibit A
Ord. 23-12 - Proposed Sewer Tier Amendment
Tier 4 "System Optional" & Unclassified to
Tier 2 "Sussex County Planning Area"



Sewer Tiers

- Tier 1 - Sussex County Unified Sanitary Sewer District
- Tier 2 - Sussex County Planning Area
- Tier 3 - Coordinated CPCN Areas
- Tier 4 - System Optional Areas
- Tier 5 - Regulated On-site Area

County of Sussex, DE, Delaware FirstMap, VITA, Esri, HERE, Garmin, INCREMENT P, USGS, EPA, USDA

Ord. No. 23-12 - Travis Martin
 Revise Sewer Tier 4 to Tier 2
 TM#s 433-11.00-17.00 & 433-11.00-17.01

Ord. No. (23-12) Sewer Tier 4 to Tier 2

Tax Parcels

Feet

0 125 250 500

N

Figure 7.3-2 Sussex County Sewer Tier Map

