



Sussex County Council Public/Media Packet

**MEETING:
November 5, 2013**

****DISCLAIMER****

This product is provided by Sussex County government as a courtesy to the general public. Items contained within are for background purposes only, and are presented 'as is'. Materials included are subject to additions, deletion or other changes prior to the County Council meeting for which the package is prepared.

**Sussex County Council
2 The Circle | PO Box 589
Georgetown, DE 19947
(302) 855-7743**

MICHAEL H. VINCENT, PRESIDENT
SAMUEL R. WILSON JR., VICE PRESIDENT
GEORGE B. COLE
JOAN R. DEEVER
VANCE PHILLIPS



2 THE CIRCLE | PO BOX 589
GEORGETOWN, DE 19947
(302) 855-7743 T
(302) 855-7749 F
sussexcountyde.gov

Sussex County Council

A G E N D A

NOVEMBER 5, 2013

10:00 A.M.

Call to Order

Approval of Agenda

Approval of Minutes

Reading of Correspondence

Todd Lawson, County Administrator

1. Proclamation – Pancreatic Cancer Awareness Month
2. 2014 Holiday Schedule and County Council Schedule
3. Administrator's Report

Gina Jennings, Finance Director

1. Fiscal Year 2014 Human Service Grants Award
2. Dental & Vision Plan Recommendations

Hal Godwin, Deputy County Administrator

1. Wastewater Agreement
 - A. Hunter's Walk

10:30 a.m. Public Hearing

Miller Creek Sanitary Sewer District – Easter Annexation



Michael Izzo, County Engineer

1. Pump Station 30 Improvements

A. Change Order No. 2

Juel Gibbons, Project Engineer

1. Airport Wetland Mitigation Project – Contract 11-06

A. Final Change Order

B. Substantial Completion

Julie Cooper, Project Engineer

1. Greenwood Library Project 07-05

A. Change Order No. 2

Grant Requests

1. Changing Fates Equine Rescue of Delaware for operating expenses.

Introduction of Proposed Zoning Ordinances

Any Additional Business Brought Before Council

Executive Session – Personnel and Land Acquisition pursuant to 29 Del. C. §10004(b)

Possible Action on Executive Session Items

Sussex County Council meetings can be monitored on the internet at www.sussexcountypde.gov.

In accordance with 29 Del. C. §10004(e)(2), this Agenda was posted on October 29, 2013 at 3:15 p.m., and at least seven (7) days in advance of the meeting.

This Agenda was prepared by the County Administrator and is subject to change to include the addition or deletion of items, including Executive Sessions, which arise at the time of the Meeting.

Agenda items listed may be considered out of sequence.

###

SUSSEX COUNTY COUNCIL



A PROCLAMATION TO RECOGNIZE PANCREATIC CANCER AWARENESS MONTH

WHEREAS, the Sussex County Council wishes to recognize organizations and individuals for their contributions to the betterment of the community; and

WHEREAS, the month of November is recognized as Pancreatic Cancer Awareness Month and is an opportunity for the public to learn about pancreatic cancer; and

WHEREAS, in 2013, an estimated 45,220 people will be diagnosed with pancreatic cancer in the United States and 38,460 will die from the disease; and

WHEREAS, pancreatic cancer is one of the deadliest cancers, is the fourth leading cause of cancer death in the United States, and is the only major cancer with a five-year relative survival rate in the single digits at just 6 percent; and

WHEREAS, when symptoms of pancreatic cancer present themselves, it is often late stage, and 73 percent of pancreatic cancer patients die within the first year of their diagnosis while 94 percent of pancreatic cancer patients die within the first five years; and

WHEREAS, approximately 120 deaths will occur as a result of pancreatic cancer in Delaware in 2013; and

WHEREAS, the incidences and death rates for pancreatic cancer are increasing and pancreatic cancer is anticipated to move from the fourth- to the second-leading cause of cancer death in the U.S. by 2020; and

WHEREAS, the United States Congress passed the *Recalcitrant Cancer Research Act* last year, which calls on the National Cancer Institute to develop scientific frameworks, or strategic plans, for pancreatic cancer and other deadly cancers, which will help provide the strategic direction and guidance needed to make true progress against these diseases; and

WHEREAS, the Pancreatic Cancer Action Network is the national organization serving the pancreatic cancer community in Sussex County and nationwide throughout a comprehensive approach that includes public policy, research funding, patient services, and public awareness and education related to developing effective treatments and a cure for pancreatic cancer; and

WHEREAS, the Pancreatic Cancer Action Network and its affiliates in Sussex County support those patients currently battling pancreatic cancer, as well as those who have lost their lives to the disease, and are committed to nothing less than a cure; and

WHEREAS, the good health and well-being of the residents of Sussex County are enhanced as a direct result of increased awareness about pancreatic cancer and research into early detection, causes, and effective treatments;

NOW, THEREFORE, BE IT RESOLVED that the Sussex County Council hereby designate the month of November 2013 as "Pancreatic Cancer Awareness Month" in Sussex County.



Michael H. Vincent, President

TODD F. LAWSON
COUNTY ADMINISTRATOR
(302) 855-7742 T
(302) 855-7749 F
tlawson@sussexcountyde.gov



Sussex County
DELAWARE
sussexcountyde.gov

Memorandum

TO: Sussex County Council
The Honorable Michael H. Vincent, President
The Honorable Samuel R. Wilson, Jr., Vice President
The Honorable George B. Cole
The Honorable Joan R. Deaver
The Honorable Vance C. Phillips

FROM: Todd F. Lawson
County Administrator

RE: **2014 HOLIDAY AND COUNCIL SCHEDULES**

DATE: November 1, 2013

During Tuesday's Council meeting, you will consider both the 2014 Holiday Schedule for the County and the 2014 County Council Schedule (select days the Council will not meet). Copies of the proposed schedules are attached. Please note, there have been no significant changes to these schedules from previous years.

If you have any questions, please contact the Clerk of the Council or myself.

TFL/kac

Attachments

pc: Ms. Robin A. Griffith

2014

JANUARY				
M	T	W	T	F
		1	2	3
6	7	8	9	10
13	14	15	16	17
20	21	22	23	24
27	28	29	30	31

FEBRUARY				
M	T	W	T	F
3	4**	5	6	7
10	11	12	13	14
17	18	19	20	21
24	25	26	27	28

MARCH				
M	T	W	T	F
3	4	5	6	7
10	11	12	13	14
17	18	19	20	21
24	25	26	27	28
31				

APRIL				
M	T	W	T	F
	1	2	3	4
7	8	9	10	11
14	15	16	17	18
21	22	23	24	25
28	29	30		

MAY				
M	T	W	T	F
			1	2
5	6	7	8	9
12	13	14	15	16
19	20	21	22	23
26	27	28	29	30

JUNE				
M	T	W	T	F
2	3	4	5	6
9	10	11	12	13
16	17	18	19	20
23	24	25	26	27
30				

JULY				
M	T	W	T	F
	1	2	3	4
7	8	9	10	11
14	15	16	17	18
21	22	23	24	25
28	29	30	31	

AUGUST				
M	T	W	T	F
				1
4	5	6	7	8
11	12	13	14	15
18	19	20	21	22
25	26	27	28	29

SEPTEMBER				
M	T	W	T	F
1	2	3	4	5
8	9	10	11	12
15	16	17	18	19
22	23	24	25	26
29	30			

OCTOBER				
M	T	W	T	F
		1	2	3
6	7	8	9	10
13	14	15	16	17
20	21	22	23	24
27	28	29	30	31

NOVEMBER				
M	T	W	T	F
3	4	5	6	7
10	11	12	13	14
17	18	19	20	21
24	25	26	27	28

DECEMBER				
M	T	W	T	F
1	2	3	4	5
8	9	10	11	12
15	16	17	18	19
22	23	24	25	26
29	30	31		

Legend	
#	No Council Meeting
#	County Day Off
#	County Off & No Council Meeting

**National Association of Conservation Districts Conference

PROPOSED

**THE SUSSEX COUNTY COUNCIL WILL NOT MEET
ON THE FOLLOWING DATES
IN THE YEAR 2014**

MARCH 4	-	NACo CONFERENCE
MARCH 11	-	WINTER HOLIDAY
APRIL 22	-	EASTER/SPRING HOLIDAY
MAY 27	-	MEMORIAL DAY HOLIDAY
JULY 1	-	SUMMER HOLIDAY
JULY 8	-	SUMMER HOLIDAY
AUGUST 26	-	SUMMER HOLIDAY
SEPTEMBER 2	-	LABOR DAY HOLIDAY
NOVEMBER 4	-	ELECTION DAY
NOVEMBER 11	-	VETERANS DAY
NOVEMBER 25	-	THANKSGIVING HOLIDAY
DECEMBER 23	-	CHRISTMAS HOLIDAY
DECEMBER 30	-	NEW YEAR HOLIDAY

SUSSEX COUNTY
2014 Holiday Schedule

<u>Holiday</u>	<u>State Observance</u>	<u>County Observance</u>
New Year's Day	January 1 (Wednesday)	January 1 (Wednesday)
Martin Luther King, Jr. Day	January 20 (Monday)	January 20 (Monday)
Good Friday	April 18 (Friday)	April 18 (Friday)
Memorial Day	May 26 (Monday)	May 26 (Monday)
Independence Day	July 4 (Friday)	July 4 (Friday)
Labor Day	September 1 (Monday)	September 1 (Monday)
Election Day	November 4 (Tuesday)	November 4 (Tuesday)
Return Day	November 6 (Thursday)	November 6 (Thursday)
Veterans Day	November 11 (Tuesday)	November 11 (Tuesday)
Thanksgiving Day	November 27 (Thursday)	November 27 (Thursday)
Day After Thanksgiving	November 28 (Friday)	November 28 (Friday)
Christmas	December 25 (Thursday) December 26 (Friday)	December 25 (Thursday) December 26 (Friday)

The County grants two floating holidays to eligible employees per calendar year in accordance with the Floating Holiday Policy.

GINA A. JENNINGS, MBA, MPA
FINANCE DIRECTOR
(302) 855-7741 T
(302) 855-7749 F
gjennings@sussexcountyde.gov



Sussex County
DELAWARE
sussexcountyde.gov

MEMORANDUM:

TO: The Honorable Michael H. Vincent
President, Sussex County Council

The Honorable Samuel R. Wilson, Jr.
Vice President, Sussex County Council

The Honorable George B. Cole
Sussex County Councilman

The Honorable Vance Phillips
Sussex County Councilman

The Honorable Joan R. Deaver
Sussex County Councilwoman

FROM: Gina A. Jennings
Finance Director 

RE: **2014 HUMAN SERVICE GRANTS**

DATE: November 1, 2013

Attached is a schedule of the 2014 Human Service Grants. On Tuesday, November 5, 2013, I will be recommending to Council that we approve those grants listed for payment.

Please call me prior to the meeting if you would like to discuss further.

GAJ/nc

Attachment

SUSSEX COUNTY COUNCIL
HUMAN SERVICE GRANTS
FISCAL YEAR 2014
1062000.56532

AGENCY	PROJECT	GRANTED FISCAL 2013	REQUESTED FISCAL 2014	AMOUNT RECOMMENDED 2014	NOTATIONS
ALZHEIMER'S ASSOCIATION	MEDIC ALERT & SAFE RETURN PROGRAM	\$ 500.00	\$ 500.00	\$ 500.00	
AMERICAN DIABETES ASSOCIATION	TO ASSIST WITH THE ADA SUGAR FREE WEEKEND RETREAT FOR CHILDREN	\$ 500.00			NO REQUEST SUBMITTED
THE ARC OF DELAWARE	TO ASSIST PERSONS WITH DEVELOPMENTAL DISABILITIES	\$ 1,000.00	\$ 1,000.00	\$ 1,000.00	
BEST BUDDIES DELAWARE	TO ASSIST WITH FUNDING FOR STUDENTS WITH IDD	\$ 500.00	\$ 5,000.00	\$ 500.00	
BIG BROTHERS/BIG SISTERS OF DELAWARE, INC.	TO COVER DIRECT SERVICE COSTS IN MATCHING CHILDREN WITH VOLUNTEERS.	\$ 1,000.00	\$ 2,000.00	\$ 1,000.00	
BOOKER STREET CHURCH OF GOD	HOUSE OF RUTH - HOUSING TO HOMELESS AND TRANSITIONING WOMEN AND ONSITE JOB READINESS TRAINING	\$ 500.00	\$ 8,375.00	\$ 500.00	
BRIDGEVILLE COMMUNITY ACTION	TO SUPPORT HAVING A FATHER & SON FAMILY NIGHT PROGRAM	\$ 1,000.00			NO REQUEST SUBMITTED
CANCER SUPPORT COMMUNITY	TO SUPPORT PSYCHOSOCIAL & EDUCATIONAL PROGRAMS	\$ 500.00	\$ 750.00	\$ 500.00	
CAN-DO PLAYGROUND AT MILFORD	TO ASSIST WITH A PLAYGROUND FOR SPECIAL NEEDS CHILDREN	\$ 500.00			NO REQUEST SUBMITTED
CAPE HENLOPEN FOOD BASKET	TO PURCHASE FOOD FOR THE FOOD BASKET	\$ 500.00	\$ 3,000.00	\$ 500.00	
CATHOLIC CHARITIES	TO ASSIST WITH CASA SAN FRANCISCO EMERGENCY SHELTER	\$ 1,000.00	\$ 10,000.00	\$ 1,000.00	
CHEER INC.	HOME SERVICE PROGRAM - HOMEBOUND SENIORS	\$ 2,500.00		\$ 2,500.00	
CHEER INC.	SHORT TERM EMERGENCY HOME HEALTH SERVICES	\$ 1,000.00		\$ 1,000.00	
CHEER CENTERS					
A.) GEORGETOWN	GENERAL SERVICES	\$ 5,000.00	\$ 5,000.00	\$ 5,000.00	
B.) GREENWOOD	GENERAL SERVICES	\$ 5,000.00	\$ 5,000.00	\$ 5,000.00	
C.) HARBOUR LIGHTS (LEWES)	GENERAL SERVICES	\$ 5,000.00	\$ 5,000.00	\$ 5,000.00	
D.) MILTON	GENERAL SERVICES	\$ 5,000.00	\$ 5,000.00	\$ 5,000.00	
E.) ROXANA	GENERAL SERVICES	\$ 5,000.00	\$ 5,000.00	\$ 5,000.00	
F.) COASTAL LEISURE CENTER	GENERAL SERVICES	\$ 5,000.00	\$ 5,000.00	\$ 5,000.00	
G.) LONG NECK (PELICAN COVE)	GENERAL SERVICES	\$ 5,000.00		\$ 5,000.00	
CHURCH OF GOD AND SAINTS OF CHRIST	ANNUAL FREE THANKSGIVING DINNER FOR ANYONE	\$ 900.00	\$ 2,000.00	\$ 900.00	
COOL SPRING CIVIC ASSOCIATION	TO PURCHASE 2 COMPUTERS AND INTERNET SERVICE	\$ -	\$ 1,840.00	\$ 500.00	NEW REQUEST
CONTACT LIFELINE	PROVIDE 24 HR PHONE CONSELING FOR RAPE VICTIMS	\$ 1,000.00			NO REQUEST SUBMITTED
COVERDALE CROSSROADS COMMUNITY COUNCIL, INC.	TO PURCHASE 2 COMPUTERS AND 1 WIRELESS ROUTER FOR A PROJECTOR	\$ 500.00	\$ 1,104.97	\$ 500.00	
DAGSBORO BOYS & GIRLS CLUB	GENERAL SERVICES	\$ 1,500.00	\$ 5,000.00	\$ 1,500.00	
DAGSBORO CHURCH OF GOD	JOSEPH'S STOREHOUSE - EMERGENCY FOOD ITEMS	\$ 1,000.00	\$ 1,500.00	\$ 1,000.00	
DELAWARE ADOLESCENT PROGRAM INC.	STAFFING & SUPPLIES	\$ 1,000.00	\$ 2,000.00	\$ 1,000.00	
DELAWARE COMMUNITY REINVESTMENT ACTION COUNCIL, INC.	TO ASSIST LOW INCOME INDIVIDUALS WITH TAXES	\$ 500.00	\$ 1,000.00	\$ 500.00	
DELAWARE CRIME STOPPERS	TO ASSIST WITH THE REWARDS PROGRAM	\$ 500.00	\$ 1,500.00	\$ 500.00	
DELAWARE FOUNDATION REACHING CITIZENS WITH COGNITIVE DISABILITIES	TO SUPPORT THE HAND-IN-HAND PROGRAM	\$ 2,500.00	\$ 5,000.00	\$ 2,500.00	

SUSSEX COUNTY COUNCIL
HUMAN SERVICE GRANTS
FISCAL YEAR 2014
1062000.56532

AGENCY	PROJECT	GRANTED FISCAL 2013	REQUESTED FISCAL 2014	AMOUNT RECOMMENDED 2014	NOTATIONS
DELAWARE GUIDANCE SERVICES	TO PROVIDE MENTAL HEALTH SERVICES FOR AT RISK CHILDREN IN SUSSEX COUNTY	\$ 2,000.00	\$ 5,000.00	\$ 2,000.00	
DELAWARE HOUSING COALITION	SUSSEX HOUSING GROUP - STAFFING & MILEAGE	\$ 2,000.00	\$ 2,000.00	\$ 2,000.00	
DELAWARE LIONS FOUNDATION	TO SUPPORT LIONS CLUB IN THEIR HUMANITARIAN SUPPORT	\$ 500.00	\$ 5,000.00	\$ 500.00	
DELAWARE NATURE SOCIETY	TO ASSIST WITH SCHOLARSHIP FUND FOR UNDERSERVED STUDENTS	\$ 1,000.00	\$ 1,000.00	\$ 1,000.00	
DELAWARE POLICE CHIEFS' COUNCIL	TO SUPPORT THE "LOCAL POLICE COORDINATION"	\$ 870.00	\$ 3,000.00	\$ 870.00	
DELMARVA CLERGY UNITED IN SOCIAL ACTION FOUNDATION	TO ASSIST WITH DIRECT SERVICES	\$ 1,000.00	\$ 2,000.00	\$ 1,000.00	
EASTER SEAL REHABILITATION CENTER	TO ASSIST WITH COMMUNITY EXPERIENCE PROGRAM	\$ 1,000.00	\$ 1,000.00	\$ 1,000.00	
EL CENTRO CULTURAL, INC.	TO ASSIST WITH FESTIVAL HISPANO	\$ 1,000.00	\$ 2,000.00	\$ 1,000.00	
ELLENDALE UNITED METHODIST CHURCH OPEN ARMS FOOD PANTRY	MONTHLY LUNCHESES TO COMMUNITY OF ELLENDALE AND PROVIDE FOOD FOR QUALIFIED CLIENTS	\$ 500.00	OPEN	\$ 500.00	NO AMOUNT SPECIFIED IN REQUEST
EVERLASTING HOPE MINISTRIES	TO ASSIST WITH TONY'S HOUSE TRANSITIONAL SHELTER	\$ 1,000.00	\$ 5,000.00	\$ 1,000.00	
FAMILIES, INDIVIDUALS AND COMMUNITIES CONFERENCE FKA: FAMILIES IN CRISIS	TO ASSIST WITH ANNUAL CONFERENCE	\$ 500.00			NO REQUEST SUBMITTED
FAMILY OUTREACH MULTIPURPOSE COMMUNITY CENTER	TO ASSIST WITH THE G.R.I.P AFTER SCHOOL PROGRAM	\$ 500.00	\$ 1,000.00	\$ 500.00	
FOOD BANK OF DELAWARE	TO HELP FUND THE CULINARY SCHOOL PROGRAM	\$ 500.00	\$ 17,100.00	\$ 500.00	
GEORGETOWN BOYS & GIRLS CLUB	YOUTH DEVELOPMENT PROGRAM	\$ 1,500.00	\$ 5,000.00	\$ 1,500.00	
GIRLS - STATE OF DELAWARE CHECK PAY. TO AMERICAN LEGION AUXILIARY	TO ASSIST WITH GIRLS STATE WEEK LONG PROGRAM	\$ 500.00	\$ 7,800.00	\$ 500.00	
GOOD SAMARITAN AID ORGANIZATION	CHRISTMAS BASKET PROGRAM	\$ 1,000.00	\$ 1,000.00	\$ 1,000.00	
GRACE TABERNACLE OF DELIVERANCE CHURCH, INC.	TO ASSIST WITH THE FAMILIES CONNECTED PROGRAM	\$ -	\$ 1,000.00	\$ 1,000.00	NEW REQUEST
GREATER LEWES COMMUNITY VILLAGE	TO PROVIDE SERVICES TO LEWES PERSONS 50 & OVER	\$ 750.00	OPEN	\$ 750.00	NO AMOUNT SPECIFIED IN REQUEST
HARVEST MINISTRIES, INC.	TO DIRECTLY ASSIST NEEDY FAMILIES IN SUSSEX	\$ -	\$ 5,000.00	\$ 1,000.00	NEW REQUEST
JUNIOR ACHIEVEMENT	YOUTH DEVELOPMENT IN SUSSEX COUNTY	\$ 1,000.00	\$ 1,500.00	\$ 1,000.00	
KENT-SUSSEX INDUSTRIES, INC.	TO COVER COST OF CLIENT'S TRANSPORTATION FOR A FULL YEAR	\$ 1,000.00	\$ 8,370.00	\$ 1,000.00	
KIWANIS FOUNDATION OF COASTAL DELAWARE	TO ASSIST WITH HIPPO THERAPY & LEADERSHIP PROGRAM	\$ 1,000.00	OPEN	\$ 1,000.00	NO AMOUNT SPECIFIED IN REQUEST
LA ESPERANZA	TO SUPPORT VICTIM SERVICES PROGRAM	\$ 1,500.00	\$ 2,500.00	\$ 1,500.00	
LA RED HEALTH CENTER	TO SUPPORT EXPANSION OF SERVICES	\$ 500.00	\$ 1,000.00	\$ 500.00	

SUSSEX COUNTY COUNCIL
HUMAN SERVICE GRANTS
FISCAL YEAR 2014
1062000.56532

AGENCY	PROJECT	GRANTED FISCAL 2013	REQUESTED FISCAL 2014	AMOUNT RECOMMENDED 2014	NOTATIONS
LAUREL BOYS & GIRLS CLUB	YOUTH DEVELOPMENT PROGRAMS	\$ 1,500.00			NO REQUEST SUBMITTED
LAUREL COMMUNITY FOUNDATION	TO HELP WITH MONTHLY EXPENSES	\$ 1,000.00	\$ 2,000.00	\$ 1,000.00	
LAUREL LIONS CLUB	TO HELP MAINTAIN TENNIS & BASKETBALL COURTS	\$ 1,000.00	\$ 1,000.00	\$ 1,000.00	
LEWES HISTORICAL SOCIETY	TO ASSIST WITH EDUCATIONAL PROGRAMS IN MARITIME HISTORY	\$ 1,000.00	\$ 1,000.00	\$ 1,000.00	
MEALS ON WHEELS OF LEWES & REHOBOTH, INC.	TO PROVIDE NUTRITIOUS MEALS EACH DAY TO HOMEBOUND SENIORS	\$ 6,000.00	\$ 10,000.00	\$ 6,000.00	
MILTON HISTORICAL SOCIETY	TO ASSIST WITH A WEEK LONG SUMMER CAME TARGETING AT RISK OR LOW INCOME ELEMENTARY & MIDDLE SCHOOL CHILDREN	\$ -	\$ 3,000.00	\$ 1,000.00	NEW REQUEST
MT. ZION CHURCH	ANNUAL LOVE FEAST - FOOD BASKETS AND NECESSITIES	\$ 500.00			NO REQUEST SUBMITTED
NATIONAL MULTIPLE SCLEROSIS SOCIETY	TO PROVIDE DIRECT ASSISTANCE	\$ 1,000.00	\$ 2,500.00	\$ 1,000.00	
NEW COVERDALE OUTREACH MISSION	TO ASSIST WITH FOOD, CLOTHING, TOYS AND GED PROGRAM	\$ 1,000.00	\$ 3,500.00	\$ 1,000.00	
NEW HOPE RECREATION & DEVELOPMENT CENTER	TO ASSIST WITH AN AFTER SCHOOL/TUTORING PROGRAM	\$ 500.00	\$ 600.00	\$ 500.00	
OAK ORCHARD/RIVERDALE BOYS AND GIRLS CLUB	YOUTH DEVELOPMENT PROGRAMS	\$ 1,500.00	\$ 10,000.00	\$ 1,500.00	
PEOPLE'S PLACE	TO PROVIDE MENTAL HEALTH SERVICES	\$ 2,000.00	\$ 4,000.00	\$ 2,000.00	
PINETOWN CMC ASSOCIATION CHECK PAY TO: FIRST STATE COMMUNITY ACTION AGENCY	TO ASSIST WITH EDUCATIONAL ENRICHMENT TO 12 COMMUNITY YOUTH	\$ 500.00	\$ 1,200.00	\$ 500.00	
PRIMEROS PASOS, INC. - FIRST STEPS	TO EXPAND EARLY CARE & EDUCATION PROGRAM	\$ 500.00	\$ 1,000.00	\$ 500.00	
READ-ALoud DELAWARE	TO HELP SOLIDIFY THEIR VOLUNTEER BASE IN SUSSEX COUNTY	\$ 1,000.00	\$ 2,000.00	\$ 1,000.00	
READING ASSIST INSTITUTE	TO PROVIDE RAI'S PARENT ASSIST PROGRAM	\$ 500.00	\$ 1,200.00	\$ 500.00	
REHOBOTH BEACH BOYS AND GIRLS	POSITIVE YOUTH DEVELOPMENT PROGRAMMING	\$ 1,500.00	\$ 5,000.00	\$ 1,500.00	
THE RONALD MCDONALD HOUSE OF DELAWARE	TO PROVIDE SERVICES REQUIRED FOR SUSSEX COUNTY CHILDREN AND THEIR FAMILIES	\$ 1,000.00	\$ 1,000.00	\$ 1,000.00	
SEAFORD HISTORICAL SOCIETY, INC.	TO ASSIST WITH THE SEARCH FOR FUNDING FOR A DIGITAL VIRTUAL DOCENT PROJECT FOR STUDENTS & TOURISTS	\$ 1,000.00	\$ 1,200.00	\$ 1,000.00	
SHECHINAH EMPOWERMENT CENTER	FOOD BASKETS	\$ 500.00	\$ 2,000.00	\$ 500.00	
SUSSEX COUNTY SENIOR CENTERS					
A.) BRIDGEVILLE	GENERAL SERVICES	\$ 5,000.00	\$ 15,000.00	\$ 5,000.00	
B.) CAPE HENLOPEN	GENERAL SERVICES	\$ 5,000.00	\$ 10,000.00	\$ 5,000.00	
C.) INDIAN RIVER	GENERAL SERVICES	\$ 5,000.00		\$ 5,000.00	NO AMOUNT SPECIFIED
D.) LAUREL	GENERAL SERVICES	\$ 5,000.00	\$ 8,000.00	\$ 5,000.00	
E.) LEWES	GENERAL SERVICES	\$ 5,000.00	\$ 5,000.00	\$ 5,000.00	
F.) MILFORD	GENERAL SERVICES	\$ 5,000.00	\$ 5,000.00	\$ 5,000.00	
G.) NANTICOKE	GENERAL SERVICES	\$ 5,000.00	\$ 7,000.00	\$ 5,000.00	
SUSSEX COMMUNITY CRISIS HOUSING SERVICES, INC.	TO ASSIST WITH THEIR MAJOR REPAIRS AND OPERATIONAL COSTS	\$ 2,000.00	\$ 5,000.00	\$ 2,000.00	

SUSSEX COUNTY COUNCIL
HUMAN SERVICE GRANTS
FISCAL YEAR 2014
1062000.56532

AGENCY	PROJECT	GRANTED FISCAL 2013	REQUESTED FISCAL 2014	AMOUNT RECOMMENDED 2014	NOTATIONS
SUSSEX COUNTY HABITAT FOR HUMANITY	FAMILY SERVICES PROGRAM	\$ 1,000.00	\$ 5,000.00	\$ 1,000.00	
SUSSEX COUNTY RETIRED AND SENIOR VOLUNTEER PROGRAM ADVISORY COMMITTEE	TO ASSIST WITH THE RSVP NIMBLE FINGERS PROJECT	\$ 500.00	\$ 1,000.00	\$ 500.00	
SUSSEX FAMILY YMCA	TO ASSIST WITH ANNUAL CAMPAIGN FOR KIDS	\$ 1,000.00	\$ 1,000.00	\$ 1,000.00	
SUSSEX PREGNANCY CARE CENTER	TO HELP WITH THE ABSTINENCE PROGRAM	\$ 1,000.00	\$ 1,000.00	\$ 1,000.00	
TEENS IN PERSPECTIVE, INC.	TO ASSIST WITH LEADERSHIP PROGRAM FOR YOUTH	\$ 500.00	\$ 8,636.00	\$ 500.00	
UCOUNT, INC.	TO PROVIDE EXPENSES FOR FATHERS ATTENDING THE SUMMIT	\$ 500.00	\$ 550.00	\$ 500.00	
UNITED WAY OF DELAWARE	TO ASSIST WITH CONTINUING FUNDING FOR EDUCATION	\$ -	\$ 5,000.00	\$ 1,000.00	NEW REQUEST
THE WAY HOME PROGRAM	ASSISTING PRISONERS WITH TRANSITION BACK IN THE COMMUNITY	\$ 1,000.00	\$ 5,000.00	\$ 1,000.00	
WESTERN SUSSEX BOYS & GIRLS CLUB	A: LAUREL BOYS & GIRLS CLUB - 5000.00 - ENHANCE SERVICES B: SEAFORD BOYS & GIRLS CLUB - 5000.00 - ENHANCE SERVICES	\$ 1,500.00	\$ 10,000.00	\$ 1,500.00	
YWCA	TO ASSIST WITH PROGRAMS FOR THE YOUTH	\$ 500.00	\$ 1,500.00	\$ 500.00	
		\$ 144,520.00	\$ 304,725.97	\$ 143,520.00	

GINA A. JENNINGS, MBA, MPA
FINANCE DIRECTOR
(302) 855-7741 T
(302) 855-7749 F
gjennings@sussexcountyde.gov



Sussex County
DELAWARE
sussexcountyde.gov

MEMORANDUM:

TO: Sussex County Council
The Honorable Michael A. Vincent, President
The Honorable Samuel R. Wilson, Vice President
The Honorable George B. Cole
The Honorable Joan R. Deaver
The Honorable Vance Phillips

FROM: Gina A. Jennings
Finance Director 

RE: **DENTAL AND VISION PLAN RECOMMENDATIONS**

DATE: November 1, 2013

During Tuesday's Council meeting, I, along with Human Resources and our insurance consultant, Insurance Buyers' Council (IBC), will be presenting the results of the dental and vision Request for Proposal (RFP).

As you are aware, the County has a dental and vision reimbursement program. This involves us processing and reimbursing all claims in-house. During the budget process, Council decided it may be best for the County and its employees to implement a new dental and vision plan.

An RFP was developed with the goals of a better benefit for employees while saving costs for the County. We received the responses from eligible providers in late September. In October, IBC evaluated the responses and presented their findings to me, Ms. Brewington, and Mr. Lawson. Since then, we have interviewed the top provider for each plan and are ready to make a recommendation to Council.

Please call me if you have any questions.

pc: Todd F. Lawson

Dental & Vision RFP

November 5, 2013

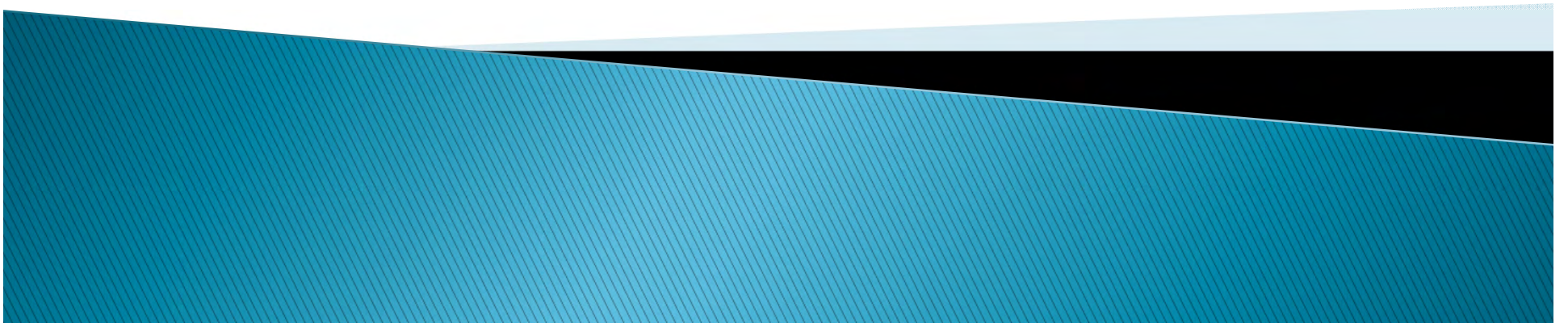

Current Dental & Vision Reimbursement Model

Total Expenses
\$1,710

First \$100 Paid

Next \$1,160 Paid
at 50%

Next \$50 Unpaid
(Deductible)

Next \$400 Paid at
80%

Total
Reimbursement
\$1,000

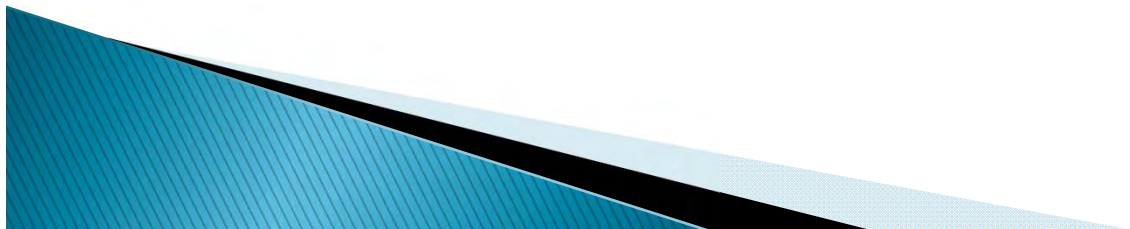

Why Move Towards Vision & Dental Insurance?



Savings per Claim – 2 Exams and Cleanings a Year – \$310.00

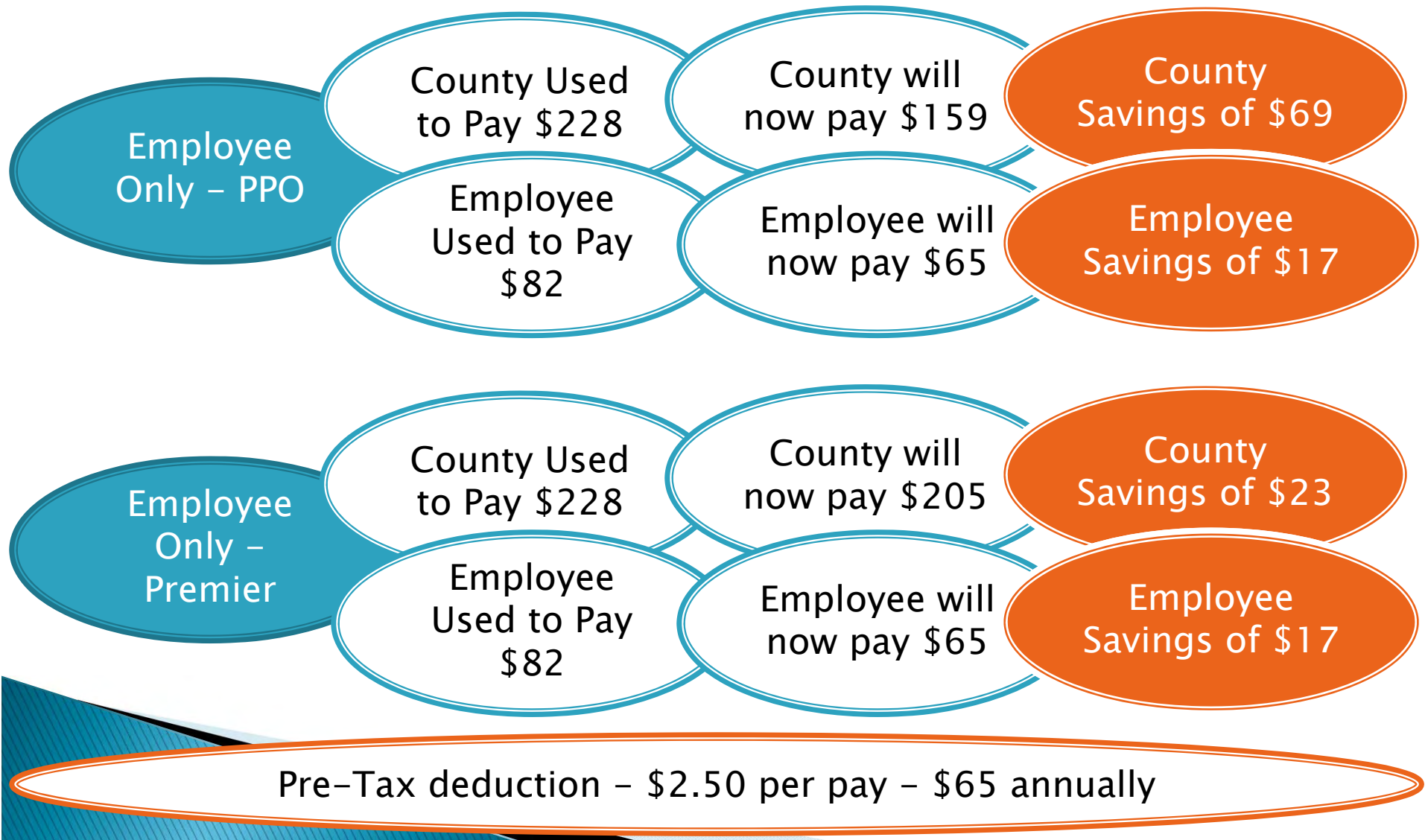

Savings per Claim – 2 Exams and Cleanings a Year – \$620.00

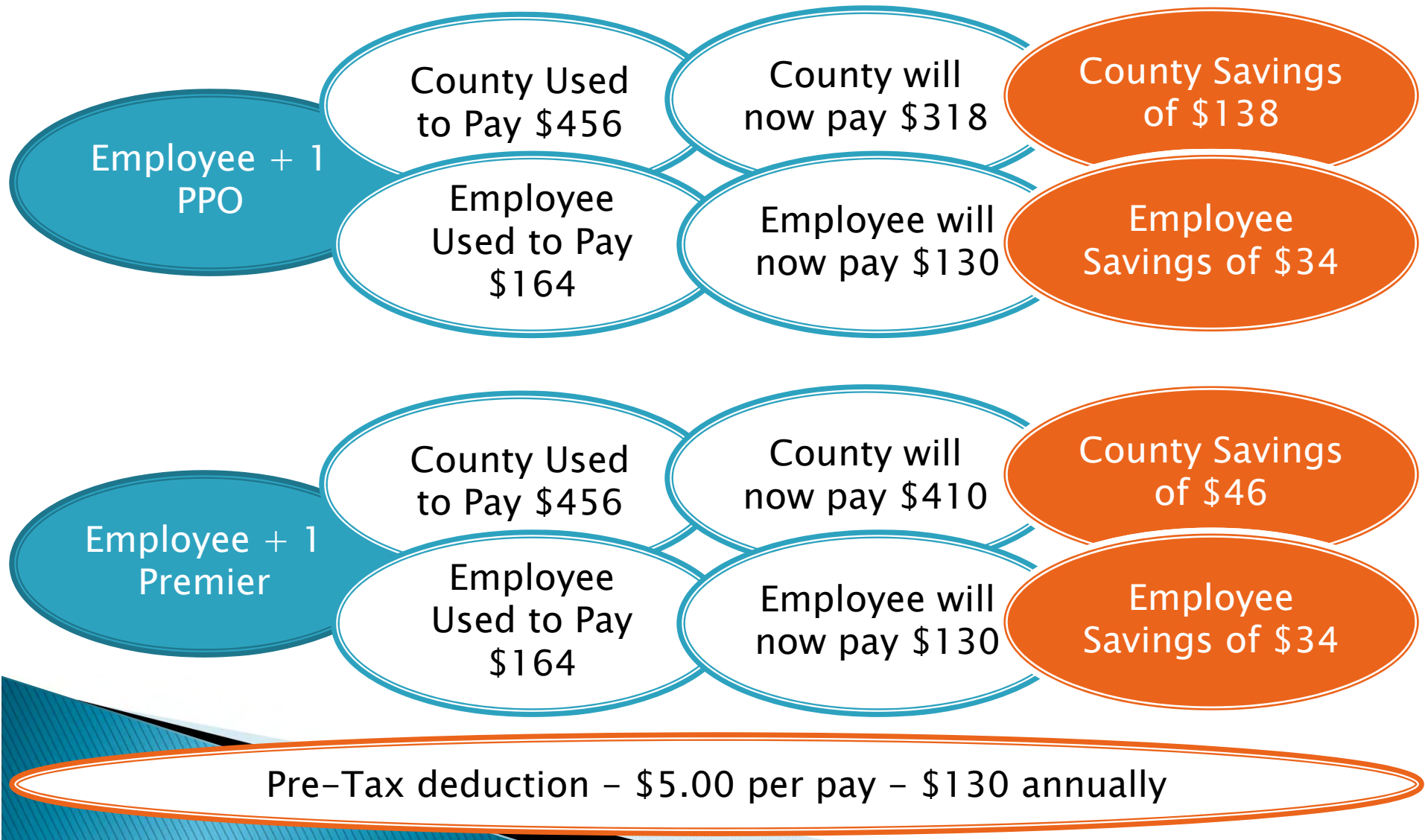

Savings per Claim - 2 Exams and Cleanings a Year - \$1240.00

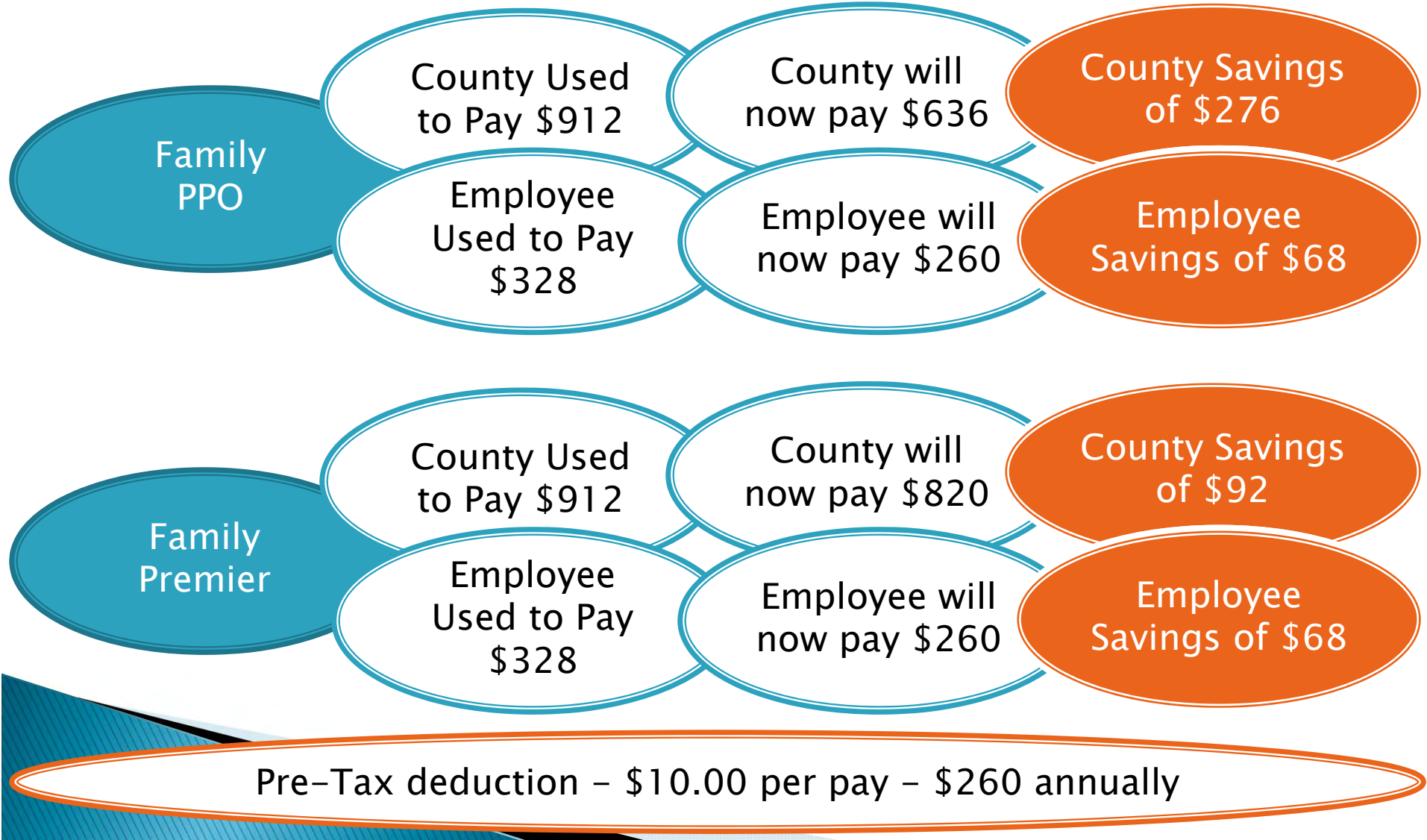

VSP VISION BENEFITS

Every 12 Months:

- ▶ WellVision Exam – Copay \$10

 - ▶ Frames – Copay \$25
 - \$150 allowance
 - 20% off amount over allowance
 - \$170 allowance featured frame brands
 - Single vision, lined bifocal, lined trifocal lenses

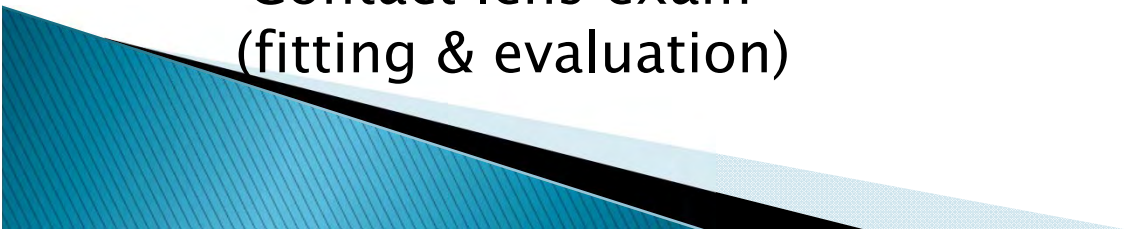
 - ▶ Contacts – Copay \$0
 - \$150 allowance
 - Contact lens exam (fitting & evaluation) Copay Up to \$60
- 

VSP VISION BENEFITS

Extra Savings & Discounts

- 20% off Additional glasses and sunglasses
- 15% off regular Laser Vision Correction or 5% off promotional price
- Savings on progressive lenses, polycarbonate lenses and various add-ons.

Deductions

Employee

Employee +1

Employee +2 or more

Per Pay

\$1.25

\$2.50

\$5.00



Estimated Annual Savings

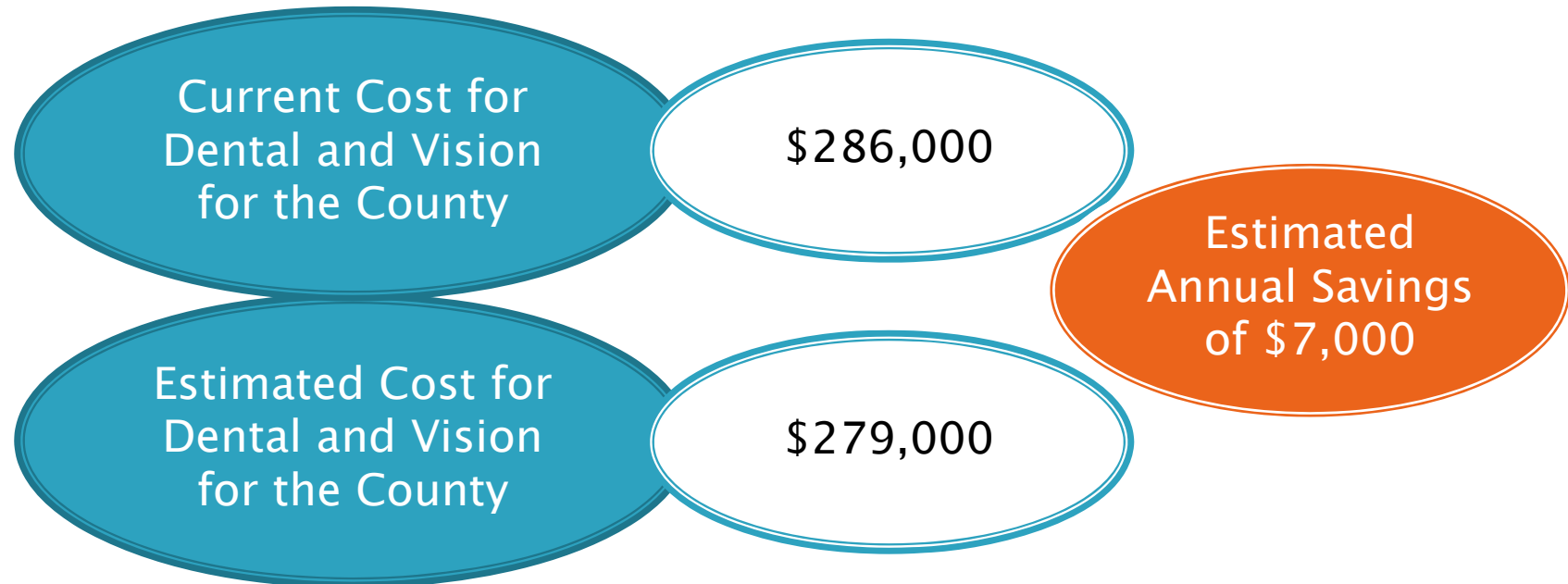

If the County is seeing a savings on every claim why is the annual savings not larger?

- Maximum is now \$1,500 for Dental instead of \$1,000 for both Dental and Vision (The County and its employees are getting more for their money)
- We anticipate more employees taking advantage of the program now that there is no longer high out-of-pocket costs before receiving a County reimbursement.

ENGINEERING DEPARTMENT

ADMINISTRATION	(302) 855-7718
AIRPORT & INDUSTRIAL PARK	(302) 855-7774
ENVIRONMENTAL SERVICES	(302) 855-7730
PUBLIC WORKS	(302) 855-7703
RECORDS MANAGEMENT	(302) 854-5033
UTILITY ENGINEERING	(302) 855-7717
UTILITY PERMITS	(302) 855-7719
UTILITY PLANNING	(302) 855-1299
FAX	(302) 855-7799



Sussex County

DELAWARE
sussexcountyde.gov

MICHAEL A. IZZO, P.E.
COUNTY ENGINEER

BRAD HAWKES
DIRECTOR OF UTILITY ENGINEERING

October 08, 2013

FACT SHEET

SUSSEX COUNTY PROJECT 81-04
HUNTERS WALK
AGREEMENT NO. 956

DEVELOPER:

Mr. Benjamin Gordy
Hunter's Walk Lewes, LLC
20184 Phillips Street
Rehoboth, DE 19971

LOCATION:

East of Kings Highway in Lewes, DE 19958

SANITARY SEWER DISTRICT:

West Rehoboth Expansion of the Dewey Beach Sanitary Sewer District

TYPE AND SIZE DEVELOPMENT:

8-18 Unit Multifamily Buildings, 3 buildings will be constructed during phase one, which will total 54 units.

SYSTEM CONNECTION CHARGES:

\$260,388.00

SANITARY SEWER APPROVAL:

Sussex County Engineering Department Plan Approval
05/09/13

Department Of Natural Resources Plan Approval
02/28/13

SANITARY SEWER CONSTRUCTION DATA:

Construction Days – 210

Construction Admin And Construction Inspection Cost – \$50,886.11

Proposed Construction Cost – \$339,240.75

ENGINEERING DEPARTMENT

ADMINISTRATION	(302) 855-7718
AIRPORT & INDUSTRIAL PARK	(302) 855-7774
ENVIRONMENTAL SERVICES	(302) 855-7730
PUBLIC WORKS	(302) 855-7703
RECORDS MANAGEMENT	(302) 854-5033
UTILITY ENGINEERING	(302) 855-7717
UTILITY PERMITS	(302) 855-7719
UTILITY PLANNING	(302) 855-1299
FAX	(302) 855-7799



Sussex County

DELAWARE
sussexcountype.gov

MICHAEL A. IZZO, P.E.
COUNTY ENGINEER

BRAD HAWKES
DIRECTOR OF UTILITY ENGINEERING

November 5, 2013

PROPOSED MOTION

BE IT MOVED THAT BASED UPON THE RECOMMENDATION OF THE SUSSEX COUNTY ENGINEERING DEPARTMENT, FOR SUSSEX COUNTY PROJECT NO. 81-04, AGREEMENT NO. 956 THAT THE SUSSEX COUNTY COUNCIL EXECUTE A CONSTRUCTION ADMINISTRATION AND CONSTRUCTION INSPECTION AGREEMENT BETWEEN SUSSEX COUNTY COUNCIL AND "HUNTER'S WALK LEWES, L.L.C.", FOR WASTEWATER FACILITIES TO BE CONSTRUCTED IN "HUNTERS WALK", LOCATED IN WEST REHOBOTH EXPANSION OF THE DEWEY BEACH SANITARY SEWER DISTRICT.

ORDINANCE NO. 38
AGREEMENT NO. 956

TODD LAWSON
COUNTY ADMINISTRATOR

RESOLUTION

A RESOLUTION TO EXTEND THE BOUNDARY OF THE MILLER CREEK SANITARY SEWER DISTRICT (MCSSD) TO INCLUDE TAX MAP AND PARCEL 134-19.00 75.03, SITUATED ON THE NORTH SIDE OF COUNTY ROAD 363 (DOUBLE BRIDGES ROAD) IN BALTIMORE HUNDRED, SUSSEX COUNTY, DELAWARE.

WHEREAS, Sussex County has established the Miller Creek Sanitary Sewer District (MCSSD); and

WHEREAS, in the best interests of the present district and to enhance the general health and welfare of that portion of Sussex County, southwest of the existing MCSSD, the inclusion of this property will be beneficial; and

WHEREAS, in accordance with 9 Del.C., Section 6502 (a), the Sussex County Council may, upon request of the County Engineer, revise the boundary of an established sewer district when 50 or more houses have been connected by posting a public notice in four public places in the district describing the new or revised boundary; and

WHEREAS, the Sussex County Council has caused to be posted a public notice in at least four public places in the district, as verified by the affidavit of Penny Massey, a copy of which affidavit and public notice is attached hereto and made a part hereof; and

WHEREAS, in accordance with 9 Del.C., Section 6502 (b), the Sussex County Council shall, within thirty days after posting the public notices pass a formal resolution establishing the new boundary of the district;

NOW, THEREFORE,

BE IT RESOLVED the Sussex County Council hereby revises the boundary of the MCSSD to include tax map 134-19.00 75.03, situated on the north side of Double Bridges Road better described, as follows:

BEGINNING at a point, situate on the northerly right of way (ROW) of Double Bridges Road, said point being approximately 2300' east of the intersection of Parker House Road & Double Bridges Road and the southeasternmost corner of lands N/F of Mary I Hentgen; thence proceeding by and with said lands of Hentgen in the following two (2) directions and distances: northwesterly ± 143 feet and southwesterly ± 109 feet to a point, said point being the northwesternmost corner of said lands of Hentgen and a point on the existing boundary of the Miller Creek Sanitary Sewer District (MCSSD); thence by and with said MCSSD boundary in the following two (2) directions and distances: northwesterly ± 395 feet and northeasterly ± 120 feet to a point, said point being the northwesternmost corner of lands N/F of Lance G Fargo; thence proceeding by and with said lands of Fargo in a southeasterly direction ± 600 feet to a point, said point being the southwesternmost corner of said lands of Fargo and a point along the northerly ROW of Double Bridges Road; thence proceeding by and with said ROW in a southwesterly direction ± 20 feet to a point, said point being that of the **BEGINNING**.

BE IT FURTHER RESOLVED that the Sussex County Council directs the County Engineer and the Attorney for the County Council to procure the necessary lands and right-of-way by purchase, agreement, or condemnation in accordance with the existing statutes; and

BE IT FURTHER RESOLVED that the County Engineer is hereby directed to prepare maps, plans, specifications, and estimates, let contracts for and supervise the construction and maintenance of, or enlarging and remodeling of, any and all structures required to provide for the safe disposal of sewage in the sanitary sewer district, as amended.

**MILLER CREEK SANITARY SEWER DISTRICT ANNEXATION
AFFIDAVIT FOR POSTING OF NOTICES**

STATE OF DELAWARE)(

COUNTY OF SUSSEX)(

BE IT REMEMBERED, That the subscriber, ROBERT LYNCH personally appeared before me and known to me personally to be such, who being by me duly sworn to law did depose and say as follows:

- A. On October 15, 2013 he was a Planning Technician for the Sussex County Engineering Department, Sussex County, State of Delaware; and
- B. On October 15, 2013 he did post the attached "Public Notice," prepared by the Sussex County Engineering Department, at the following locations:
 1. On the area of land being considered for the proposed annexation of the Miller Creek Sanitary Sewer District being part of tax map reference 1-34-19.00 Parcel 75.03, in four (4) locations as follows:
 - a. On a driven stake located along the northerly right of way (ROW) of Double Bridges Rd (County Road 363);
 - b. On a driven stake located along the northerly right of way (ROW) of Double Bridges Rd (County Road 363);
 - c. On a driven stake near the northwestern property corner in the area of the easement;
 - d. On a driven stake near the northwestern property corner in the area of the easement;
 2. On a driven stake at the exit of Plantation Park 1 near community mail boxes.
 3. On a driven stake at the entrance of Malcolm's Manor subdivision near the community entrance sign.
 4. On a Delaware Electric Cooperative pole number 25106 located near the westerly property corner of parcel 1-34-19.00-19.01.
 5. On a driven stake near the entrance of Forest landing subdivision located at the intersection of Eagle Ln and

Beaver Dam Rd (County Road 368).

ROBERT LYNCH

SWORN TO AND SUBSCRIBED before me on this 17th day of Oct A.D., 2013.

NOTARY PUBLIC

My Commission Expires _____
Jayne E. Dickerson
Notary Public
Commission Expires 5/31/2015

PROPOSED

PUBLIC NOTICE
PROPOSED EXPANSION OF THE
MILLER CREEK SANITARY SEWER DISTRICT
TAX MAP AND PARCEL NUMBER 134-19.00-75.03
LANDS OF THOMAS & MEGAN EASTER
FILE NUMBER: MC-10.03.09

NOTICE IS HEREBY GIVEN that the Sussex County Council voted on September 17, 2013, to consider expanding the boundary of the Miller Creek Expansion of the Bethany Beach Sanitary Sewer District to include tax map and parcel 134-19.00-75.03, land now or formerly (N/F) of Thomas & Megan Easter, situated on the north side of County Road 363(Double Bridges Road). The parcel is located in the Baltimore Hundred, Sussex County, Delaware and recorded in the Office of the Recorder of Deeds, in and for Sussex County, Delaware.

BEGINNING at a point, situate on the northerly right of way (ROW) of Double Bridges Road, said point being approximately 2300' east of the intersection of Parker House Road & Double Bridges Road and the southeasternmost corner of lands N/F of Mary I Hentgen; thence proceeding by and with said lands of Hentgen in the following two (2) directions and distances: northwesterly ± 143 feet and southwesterly ± 109 feet to a point, said point being the northwesternmost corner of said lands of Hentgen and a point on the existing boundary of the Miller Creek Sanitary Sewer District (MCSSD); thence by and with said MCSSD boundary in the following two (2) directions and distances: northwesterly ± 395 feet and northeasterly ± 120 feet to a point, said point being the northwesternmost corner of lands N/F of Lance G Fargo; thence proceeding by and with said lands of Fargo in a southeasterly direction ± 600 feet to a point, said point being the southwesternmost corner of said lands of Fargo and a point along the northerly ROW of Double Bridges Road; thence proceeding by and with said ROW in a southwesterly direction ± 20 feet to a point, said point being that of the **BEGINNING**.

The proposed expansion of the MCSSD is within these boundaries and said to contain 1.46 acres, more or less. The boundary description has been prepared using Sussex County tax map number 134-19.00.

A map outlining and describing the extension to the MCSSD is attached. The area involved is crosshatched.

The public hearing will be held on this issue at 10:30 am on November 5, 2013 in the Sussex County Council Chambers. All interested persons, officials, residents, voters, taxpayers, property owners, or corporations in any way affected by this boundary extension are welcome to attend. There will be an opportunity for questions and answers. The Sussex County Council following the hearing, at one of their regularly scheduled meetings, will make the final decision on the boundary extension.

For further information, please call or write the Sussex County Engineering Department, 2 The Circle, Post Office Box 589, Georgetown, DE 19947 – (302) 855-1299.

Michael A. Izzo, P.E.
County Engineer

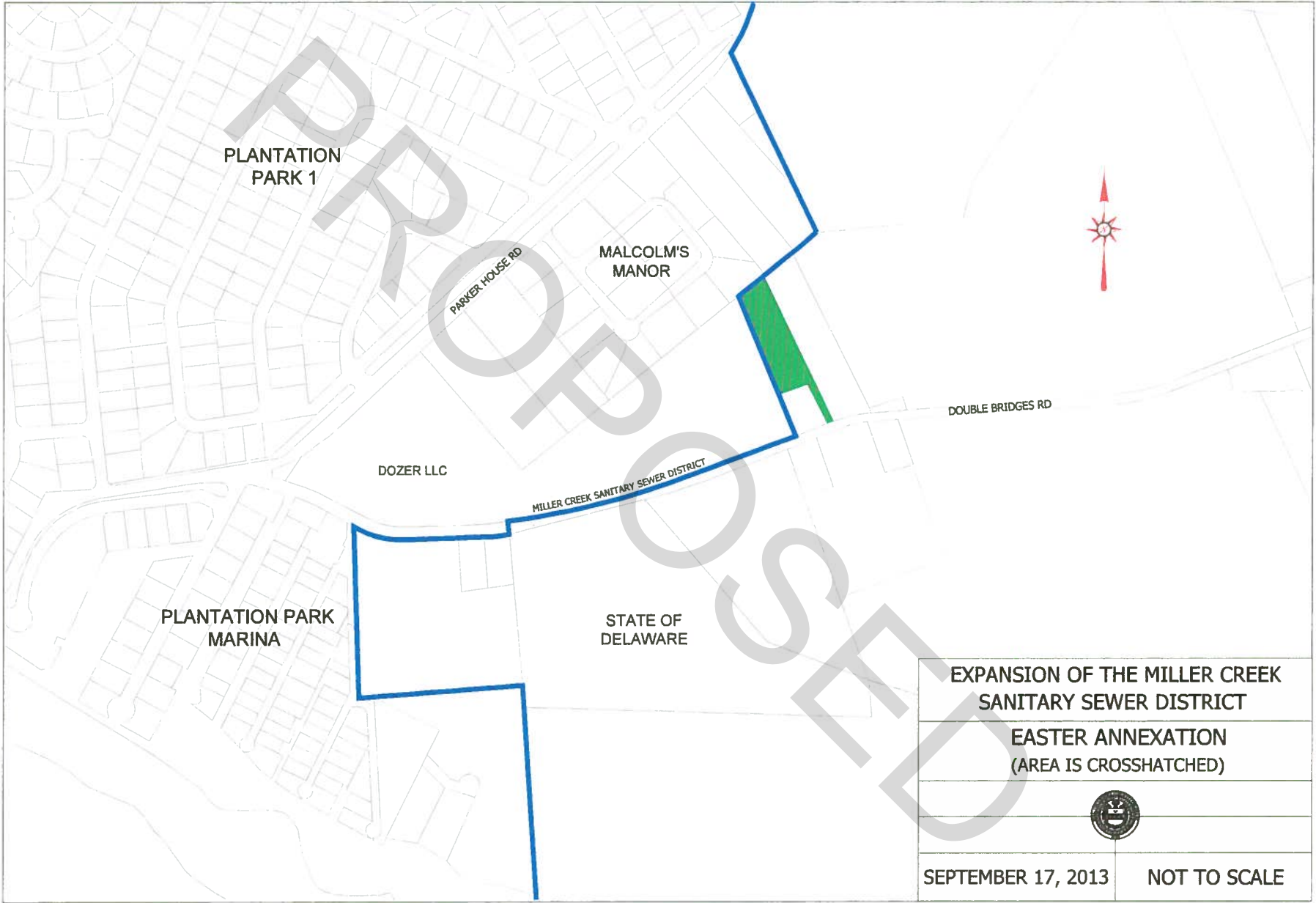

Change Order

No. 2

Date of Issuance: October 23rd, 2013 Effective Date: October 23rd, 2013

Project: P.S. #30 Improvements	Owner: Sussex County	Owner's Contract No.: 09-17
Contract: South Coastal Regional Wastewater Facilities (SCRWF)	Date of Contract: April 2 nd , 2012	
Contractor: Bearing Construction, Inc.	Engineer's Project No.: 14207-003	

The Contract Documents are modified as follows upon execution of this Change Order:

Description: Provide/install "shielded cables" to pump "MAS" units, install (7) new ARV's on the existing 18" force main, credit to provide alternative check valves and 114 calendar day, "zero" dollar, Contract time extension.

Attachments (list documents supporting change): Line Item 1 - (Shielded Cables to MAS Units), Line Item 2 (Install ARV Units), Line Item 3 - (Alternative Check Valve Cost Credit) and Line Item 4 - (Time Extension)

CHANGE IN CONTRACT PRICE:

CHANGE IN CONTRACT TIMES:

Original Contract Price:

Original Contract Times: 365 Calendar days

\$ 3,449,460.00

Substantial Completion (days or date): 365 days

Ready for final payment (days or date): _____

[Decrease] from previously approved Change Orders No. 1 to No. 1:

[Increase] from previously approved Change Orders No. 1 to No. 1:

\$ (-9,794.10)

Substantial Completion (days): 0 days

Ready for final payment (days): _____

Contract Price prior to this Change Order:

Contract Times prior to this Change Order:

\$ 3,439,665.90

Substantial Completion (days or date): 365 days

Ready for final payment (days or date): _____

Decrease of this Change Order:

Increase of this Change Order: 114 calendar days

\$ (-6,878.10)

Substantial Completion (days or date): 479 days

Ready for final payment (days or date): _____

Contract Price incorporating this Change Order:

Contract Times with all approved Change Orders:

\$ 3,432,787.80

Substantial Completion (days or date): 479 days

Ready for final payment (days or date): _____

RECOMMENDED:

ACCEPTED:

ACCEPTED:

By: Michael J. Gilbert
Engineer (Whitman, Requardt & Assoc.)

By: _____
Owner (Sussex County)

By: JCR
Contractor (Bearing Construction, Inc.)

Date: 10-24-2013

Date: _____

Date: 10-24-2013

Approved by Funding Agency (if applicable):

Date: _____

Line Item No. 1

(Installation of Shielded Cable Conductors to MAS Units)

Gilbert, Michael

From: Jim Merrell <Jim@bearingconstruction.net>
Sent: Saturday, June 29, 2013 3:44 PM
To: Hinz, Will
Cc: Gilbert, Michael; John Shelalis; Danny Porter; Kenny Stubbs
Subject: Re: Pump Station 30

Yes.

Sent from my iPad

On Jun 29, 2013, at 3:37 PM, "Hinz, Will" <WHinz@wrallp.com> wrote:

Jim,

I assume that this information was provided for our general information. We have no additional comments.

Will

From: Jim Merrell [<mailto:Jim@bearingconstruction.net>]
Sent: Wednesday, June 26, 2013 7:20 AM
To: Hinz, Will
Cc: Gilbert, Michael; 'John Shelalis'; Danny Porter; Kenny Stubbs
Subject: FW: Pump Station 30

James R Merrell
Bearing Construction
ph. 410-556-6100
fax. 410-556-6574
<image003.gif>

From: Tom Schell [<mailto:TSchell@riordanmat.com>]
Sent: Tuesday, June 25, 2013 3:42 PM
To: Jim Merrell
Subject: FW: Pump Station 30

Jim,

Enclosed is Jim Vukich's response concerning the question about what the cable should be between the junction box and the MAS unit for the Flygt / Xylem submersible pumps we supplied on your Pump Station #30 project. Please contact me should you have any questions.

Sincerely,
Tom Schell

Overall Foil/Braid Shield

Computer Cables for EIA RS-232 Applications

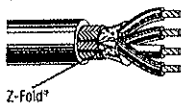
Description	Part No.	UL NEC/ C(UL) CEC Type	No. of Cond.	Color Code	Standard Lengths		Standard Unit Weight		Nominal OD		Nominal DCR		Nominal Capacitance			
					Ft.	m	Lbs.	kg	Inch	mm	Cond.	Shield	* pF/ Ft.	* pF/ m	** pF/ Ft.	** pF/ m
22 AWG Stranded (7x30) Tinned Copper Conductors • Overall Beldfoil® (100% Coverage) + Tinned Copper Braid Shield (65% Coverage)																
Semi-rigid PVC Insulation • Chrome PVC Jacket																
UL AWM Style 2464 (300V 80°C)	9939	NEC: CMG CEC: CMG FT4	3	See Chart 1 (Tech Info Section)	100 500 1000	30.5 152.4 304.8	3.6 14.0 27.0	1.6 6.4 12.3	.202	5.13	14.7Ω/M' 48.2Ω/km	6.2Ω/M' 20.3Ω/km	37	121	67	220
	9940	NEC: CMG CEC: CMG FT4	4	See Chart 1 (Tech Info Section)	100 500 1000	30.5 152.4 304.8	4.0 16.5 32.0	1.8 7.5 14.5	.215	5.46	14.7Ω/M' 48.2Ω/km	5.0Ω/M' 16.4Ω/km	37	121	67	220
	9941	NEC: CMG CEC: CMG FT4	5	See Chart 1 (Tech Info Section)	100 500 1000	30.5 152.4 304.8	4.2 19.0 38.0	1.8 8.6 17.3	.230	5.84	14.7Ω/M' 48.2Ω/km	7.1Ω/M' 23.3Ω/km	37	121	67	220
	9942	NEC: CMG CEC: CMG FT4	6	See Chart 1 (Tech Info Section)	100 500 1000	30.5 152.4 304.8	4.7 22.0 43.0	2.1 10.0 19.5	.245	6.22	14.7Ω/M' 48.2Ω/km	7.9Ω/M' 25.9Ω/km	35	115	63	207
	9943	NEC: CMG CEC: CMG FT4	7	See Chart 1 (Tech Info Section)	100 500 1000	30.5 152.4 304.8	5.0 23.5 46.0	2.3 10.8 20.9	.245	6.22	14.7Ω/M' 48.2Ω/km	7.0Ω/M' 23.0Ω/km	35	115	63	207
	9944	NEC: CMG CEC: CMG FT4	8	See Chart 1 (Tech Info Section)	100 500 1000	30.5 152.4 304.8	5.5 26.0 52.0	2.5 11.8 23.6	.260	6.60	14.7Ω/M' 48.2Ω/km	6.0Ω/M' 19.7Ω/km	35	115	63	207
	9945	NEC: CMG CEC: CMG FT4	9	See Chart 1 (Tech Info Section)	100 500 1000	30.5 152.4 304.8	6.1 28.5 57.0	2.8 12.9 25.9	.280	7.11	14.7Ω/M' 48.2Ω/km	5.1Ω/M' 16.7Ω/km	35	115	63	207
	9946	NEC: CMG CEC: CMG FT4	10	See Chart 1 (Tech Info Section)	100 500 1000	30.5 152.4 304.8	6.6 31.5 62.0	3.0 14.3 28.1	.300	7.62	14.7Ω/M' 48.2Ω/km	4.6Ω/M' 15.1Ω/km	35	115	63	207
	9947	NEC: CMG CEC: CMG FT4	15	See Chart 2R (Tech Info Section)	100 500 1000	30.5 152.4 304.8	8.7 42.5 83.0	4.0 19.3 37.7	.340	8.64	14.7Ω/M' 48.2Ω/km	4.1Ω/M' 13.5Ω/km	35	115	63	207
	9948	NEC: CMG CEC: CMG FT4	25	See Chart 2R (Tech Info Section)	100 500 1000	30.5 152.4 304.8	13.3 66.5 132.0	6.0 30.2 59.9	.410	10.41	14.7Ω/M' 48.2Ω/km	3.1Ω/M' 10.2Ω/km	35	115	63	207
	9949	NEC: CMG CEC: CMG FT4	37	See Chart 2R (Tech Info Section)	100 500 1000	30.5 152.4 304.8	16.1 87.5 180.0	7.3 39.7 81.7	.460	11.68	14.7Ω/M' 48.2Ω/km	2.7Ω/M' 8.9Ω/km	35	115	63	207
	9950	NEC: CMG CEC: CMG FT4	50	See Chart 2R (Tech Info Section)	100 500 1000	30.5 152.4 304.8	25.2 118.0 238.0	11.4 53.6 108.1	.555	14.10	14.7Ω/M' 48.2Ω/km	2.3Ω/M' 7.5Ω/km	35	115	63	207

Use to extend 12-Lead Cable

Use to extend 24-Lead Cable

4 • Multi-Conductor Cables

DCR = DC Resistance
 *Capacitance between conductors.
 **Nominal capacitance conductor to conductor and shield.





Jim,
Yes please proceed.

From: Hinz, Will [<mailto:WHinz@wrallp.com>]
Sent: Friday, June 21, 2013 1:15 PM
To: Jim Merrell
Cc: Gilbert, Michael; rmarvel@sussexcountyde.gov; Brad Hawkes
Subject: RE: Pump Station 30

Jim,
Yes please proceed. We will incorporate into the next project change order. The only question we need to verify is if the size/type of wire being installed acceptable to Flygt. Please confirm with the pump manufacturer representative prior to proceeding and forward any related correspondence for our file.

Thank You,

Will

From: Jim Merrell [<mailto:Jim@bearingconstruction.net>]
Sent: Friday, June 21, 2013 11:18 AM
To: Hinz, Will
Cc: Gilbert, Michael; rmarvel@sussexcountyde.gov
Subject: FW: Pump Station 30

Will,

Please see attached breakdown from Mid-Atlantic for changing the wire to shield. Should I tell them to proceed?

James R Merrell
Bearing Construction
ph. 410-556-6100
fax. 410-556-6574



John,
Attached is the proposal to change out the conductors to shielded conductors.

From: John Shelalis [<mailto:jshelalis@maes1.com>]
Sent: Friday, June 21, 2013 6:41 AM
To: Jim Merrell
Subject: RE: Pump Station 30

Jim, attached is the proposal to change out the conductors to shielded conductors.

Thanks, John.

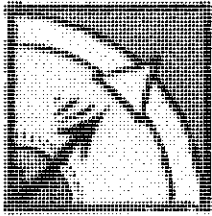

BEARING CONSTRUCTION, INC.

805 Shine Smith Road
Sudlersville, MD 21668
410/556-6100
410/556-6574

6/21/2013

Whitman, Requardt and Associates, LLP
21553 Rudder Lane
Georgetown, DE 19947

Project: South Coastal Regional Wastewater Facilities
P.S. #30 Improvements
Contract No. 09-17

Attn: Michael J. Gilbert

Re: Shielded Cables

Bearing is pleased to submit this PCO for installing shielded conductors to the MAS.

Mid-Atlantic Electrical Services

Labor	\$ 622.50
Material	\$ 387.19
Overhead	\$ 151.45
Bearing Mark Up	\$ 58.06

Total **\$ 1,219.20**

Please see attached.

James Merrell
President

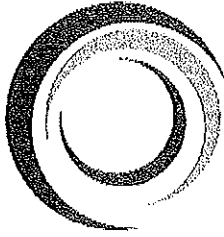

Mid-Atlantic Electrical Services Inc.

24556 Betts Pond Road
Millsboro, DE. 19966

Electrical Contractors

Phone: 302-934-7171
Fax: 302-934-7170

PROPOSAL

June 21, 2013

To: Bearing Construction, Inc.
Attn: Jim Merrill
Project: PS 30

Our price for removing conductors from MASA and installing shielded conductors is \$1,161.14

Included in the base bid price:

1. Provide and install shielded conductors with forked sta-con terminals.
2. Remove existing conductors.

Please note the following qualifications:

1. Price is based on prevailing wage rates.
2. Our pricing is based on the entire work area to be available without interruption.
3. We have no monies in our bid for any cutting, patching or painting.
4. We have no monies in our bid for any blocking, bracing or structural support.
5. Dumpster to be provided by others.

All work will be performed in a workmanlike manner for the price stated above with payment terms as follows:
Net 30 days.

Respectfully submitted _____

John Shelalis Project Manager/Mid Atlantic Electrical Services, Inc.

This price does not include any bonding or utility company fees unless specifically stated above. Price is valid for 30 days only, after which it may be cancelled or revised without further notice. If the cost of materials used in this quote escalates more than 10% from the time of purchase we reserve the right to be compensated for the increase via change order. This price does not include any bonding or utility company fees unless specifically stated above.

BREAK DOWN OF CHANGE ORDER

JOB NAME: PS 30

JOB #: 120760

DATE: 6/21/2013

Provide materials and labor to remove conductors for MAS and replace with shielded conductors.

LABOR	10	HRS.	@	\$59.00	PER HR.	\$ 590.00
NON PRODUCTIVE LABOR						
PROJECT MANAGER	5%			\$65.00	PER HR.	\$ 32.50
Trencher				\$0.00		\$0.00
Vendor/Subcontractor						\$ -
MATERIALS						\$ 339.99
SALES TAX	0%					\$0.00
SUB TOTAL						\$ 962.49
COSUMABLES	2%	of Direct Labor				\$ 11.80
SMALL TOOLS	2%	of Direct Labor				\$ 11.80
SAFETY	2%	of Direct Labor				\$ 11.80
WARRANTY	1%	of Direct Labor				\$ 5.90
CLOSE-OUT	1%	of Direct Labor				\$ 5.90
PRIME COST						\$ 1,009.69
OVERHEAD	15%					\$ 151.45
Mark-up	0%					\$ -
JOB TOTAL						\$ 1,161.14
BOND	0%					\$0.00
TOTAL						\$ 1,161.14

Line Item No. 2

(Installation/Replacement of New Air Release Valves)

Change Order - ARV's
Cont B-4

Gilbert, Michael

From: Gilbert, Michael
Sent: Friday, July 19, 2013 2:42 PM
To: 'Jim Merrell'
Cc: bhawkes@sussexcountyde.gov; Edward.Maloney@state.de.us;
rmarvel@sussexcountyde.gov; rrogers@sussexcountyde.gov; kstubbs185@gmail.com;
Hinz, Will
Subject: RE: ARV's

Jim: On behalf of Sussex County Engineering Department (SCED), WR&A hereby approves and directs Bearing Construction Company (BCC) to proceed with the provision of all equipment, labor, materials, M.O.T. and other ancillary safety/minor work efforts (in agreement with DelDOT Standard Specifications) needed to replace the remaining 6 ARV's (5 on the 18" force main and one on the adjacent 10" force main according to Rodney Marvel and Bobby Rogers).

BCC is to provide the 6 – 2" S.S. ball valves, S.S. nipples and S.S. unions needed to complete the replacement work. Sussex County Environmental Services (SCES) will purchase and provide the new ARV units to BCC work forces. With proper field coordination from BCC field supervisors, it is WR&A's understanding that SCES will also provide a "vactor" unit to assist in the removal/collection of sewage from the 18"/10" force mains. BCC is to provide SCES with the removed ARV units. SCES will dispose of the old "faulty" ARV mechanical assembly.

Since the bulk of the work involves the prevention of BCC's current crew from proceeding with the final connection and grading at the project site, we intend to use Contingent Item B-4 (Down Time of 23 Hours @ \$300/hour) as a total payment of \$6,900.00 for this work. (The cost and scope of work is based on BCC's proposed cost estimate date July 15, 2013.)

It is WR&A's understanding the DelDOT (Ed Maloney) has been informed and has given approval of BCC crew's scheduled commencement of the installation work (installation of the 2" S.S. ball valves and S.S. nipples on the 18" force main) on Monday, July 22nd, 2013 provided that all required M.O.T. signage and flagging personnel are implemented at the site. It is also WR&A's understanding that both SCES and Bearing will be taking part in this initial part regarding the replacement of the remaining (6) faulty ARV units.

Please contact this office should WR&A's understanding be inaccurate or if something has changed regarding acquisition of materials, crew scheduling, weather or any other pertinent items (such as BCC's disagreement with the aforementioned statements).

Thank you.

Mike Gilbert

Whitman, Requardt & Associates, LLP

From: Jim Merrell [<mailto:Jim@bearingconstruction.net>]
Sent: Tuesday, July 16, 2013 10:33 AM
To: Gilbert, Michael
Cc: 'Rodney Marvel'
Subject: ARV's

Mike

This is what I have for the ARV's based on the work this morning. Let me know what you think. Thanks

James R Merrell
Bearing Construction
ph. 410-556-6100
fax. 410-556-6574



ARV Labor breakdown

	Rate/hr	Hours		
Pipe Labor	24.00	2.00	\$	48.00
Pipe Labor	24.00	2.00	\$	48.00
Operator	24.00	1.00	\$	24.00
Flagger	25.00	2.00	\$	50.00
Flagger	25.00	2.00	\$	50.00
Formen	65.00	2.00	\$	130.00
Totals			\$	350.00
7 ARV's			\$	2,450.00

Equipment Breakdown

	Rate/hr	Hours		
Rubber Track Excavator	90.00	14.00	\$	1,260.00
Pick Up Truck with Tools	35.00	14.00	\$	490.00
Totals			\$	1,750.00



FERGUSON WATERWORKS #1835
 88 INDUSTRIAL PARK CIRCLE
 WALDORF, MD 20602-0068

Deliver To: justin.colton@ferguson.com
 From: Justin Colton
 Comments:

10:12:50 JUL 16 2013

FERGUSON WATERWORKS #1800

Page # 1

Price Quotation
 Phone : 301-870-7901
 Fax : 301-870-7909

Bid No.....: 8260145

Bid Date....: 07/16/13

Quoted By.: JPC

Cust 410-556-6064

Terms.....: NET 10TH PROX

Customer: BEARING CONSTRUCTION INC
 805 SHINE SMITH ROAD
 SUDLERSVILLE, MD 21668

Ship To: BEARING CONSTRUCTION INC
 805 SHINE SMITH ROAD
 SUDLERSVILLE, MO 21668

Cust PO#...:

Job Name: ? SS

Item	Description	Quantity	Net Price	UM	Total
A7610801	2 SS 1500# THRD SP BV	6	249.883	EA	1499.30
DS46NKU	2X6 SS S40 316 NIP	12	13.133	EA	157.60
IS6CTUK	2 SS 316 150# THRD UNION	6	24.243	EA	145.46
Net Total:					\$1802.36
Tax:					\$108.15
Freight:					\$0.00
Total:					\$1910.51

Quoted prices are based upon receipt of the total quantity for immediate shipment (48 hours). SHIPMENTS BEYOND 48 HOURS SHALL BE AT THE PRICE IN EFFECT AT TIME OF SHIPMENT UNLESS NOTED OTHERWISE. Seller not responsible for delays, lack of product or increase of pricing due to causes beyond our control, and/or based upon Local, State and Federal laws governing type of products that can be sold or put into commerce. This quote is offered contingent upon the buyer's acceptance of Seller's terms and conditions, which are incorporated by reference and found either following this document, or on the web at http://wolselley.com/terms_conditionsSale.html. Govt Buyers: All items are open market unless noted otherwise.

LEAD LAW NOTICE: Brass/bronze products without "LF" in the description field may contain lead and thus not comply with low lead laws. These products must not be used in potable water applications.

Gilbert, Michael

From: Gilbert, Michael
Sent: Thursday, July 11, 2013 10:58 AM
To: 'Brad Hawkes'
Subject: RE: ARV locations

Brad: WR&A, (in discussion with Bearing's field superintendent Danny Porter), believes that one ARV "exchange" can be done in 2 to 4 hours. Rodney Marvel mentioned the possible addition of one more ARV replacement on a 10" force main so it could take up to 3.5 days (3 days total if not counting Tuesday's proposed ARV replacement along Old Mill Bridge Road).

As for M.O.T., WR&A's understanding is sufficient flagging personnel to stop and direct traffic around a very small area of road way (around 100 LF +/-) and perhaps a basic construction warning sign or two regarding Work Ahead and Lane Closed Ahead is all that will be needed.

As for work, mechanical only and only within the existing manhole structures. There will be no disturbance of pavement or excavation(s) of any kind.

If it would help DeIDOT to give the "O.K." to do this work in a very prompt time frame, Bearing would be open to performing only one "exchange" per day (although two per day is Bearing's preference).

Please get back to WR&A as soon as DeIDOT defines their requirements so we can provide final direction/information to the Contractors (in order to obtain the most cost effective price quotes regarding WR&A's previous request for cost proposals).

Thank you.

Mike Gilbert
Whitman, Requardt & Associates, LLP

-----Original Message-----

From: Brad Hawkes [<mailto:bhawkes@sussexcountyde.gov>]
Sent: Wednesday, July 10, 2013 2:50 PM
To: Gilbert, Michael
Subject: ARV locations

Gilbert

Will be reviewing the attached with DeIDOT regarding MOT..... in your opinion would it be safe to say:

"single lane closure for a few hours at each location... total estimate 3 work days"
"mechanical work within existing MH, no pavement disturbance intended"

Brad

-----Original Message-----

From: Xerox7525@sussexcountyde.gov [<mailto:Xerox7525@sussexcountyde.gov>]

Gilbert, Michael

From: Gilbert, Michael
Sent: Monday, July 01, 2013 11:58 AM
To: jim@bearingconstruction.net
Cc: bhawkes@sussexcountyde.gov; rmarvel@sussexcountyde.gov;
rrogers@sussexcountyde.gov; Hinz, Will
Subject: FW: extra work ARV's
Attachments: Scanned from a Xerox multifunction device001.pdf; Image.jpg

Jim: Please provide a lump sum quote to perform the SCED/SCES requested removal of existing ARV units and subsequent replacement of the ARV's on the County's existing 18" diameter force main at the approximate locations shown on the attached scanned sketch and drawing detail. Bobby Rogers of SCED knows the exact locations of the ARV's should you have any questions. Bobby's cell phone number is 302-542-1376.

Due to the ARRA requirements for the 09-17 Contract, Sussex County will purchase and provide the new/replacement ARV units that they currently prefer. BCI's part will be to provide ARRA approved S.S. nipples, S.S. ball valves needed to perform the installation, as well as, all coordination, labor, equipment, M.O.T. and other ancillary safety/minor work efforts at each of the six locations. Please include and show all Contract required, labor, material and cost break-outs, mark-ups and any request for Contract time related items as part of the lump sum cost proposal.

Please contact this office at 302-855-9840 should you have any questions.

Thank you.

Mike Gilbert
Whitman, Requardt & Associates, LLP

-----Original Message-----

From: Brad Hawkes [<mailto:bhawkes@sussexcountyde.gov>]
Sent: Monday, July 01, 2013 11:09 AM
To: Gilbert, Michael
Subject: extra work ARV's

Gilbert

See attached ARV's (6) for possible CO with either B&M or Bearing

Brad

-----Original Message-----

From: Xerox7525@sussexcountyde.gov [<mailto:Xerox7525@sussexcountyde.gov>]
Sent: Monday, July 01, 2013 10:52 AM
To: Brad Hawkes
Subject: Scanned from a Xerox multifunction device

6/28/13

ARV Replacements on 18" ϕ F.M.

* Provide all required M.O.T. *
per DelDOT Specifications,
and wages per the Contract
documents.

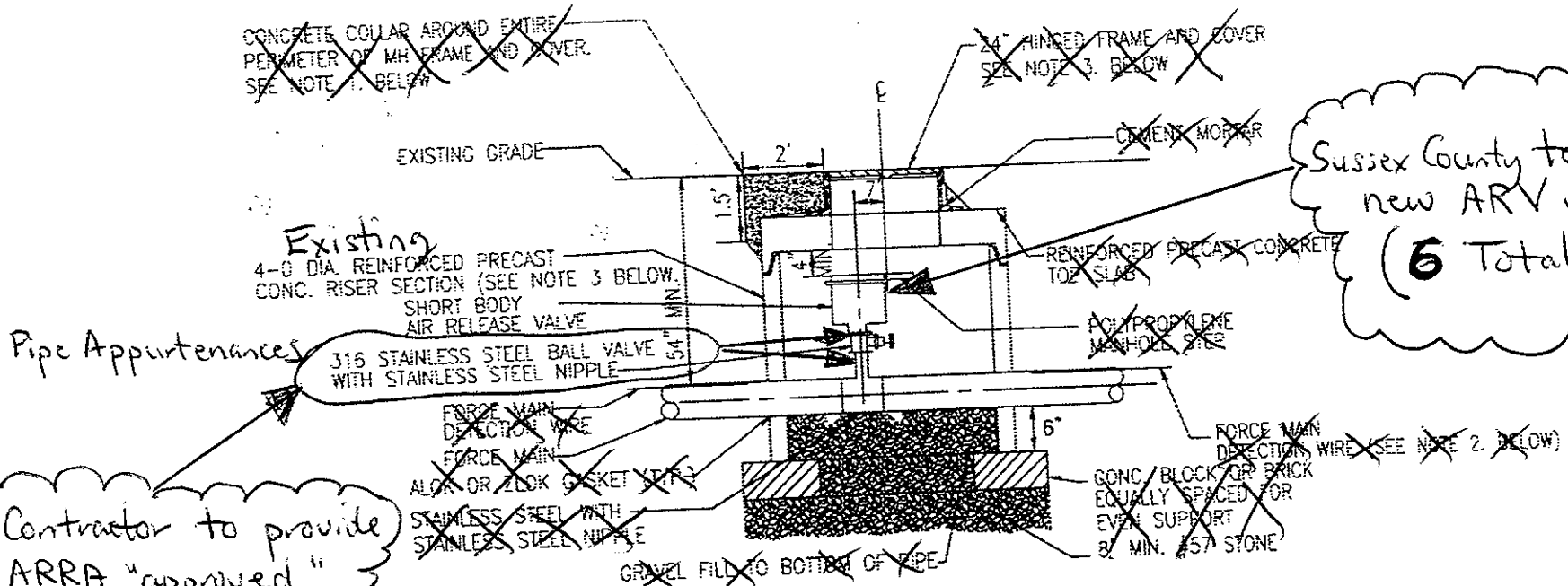

Sussex County to provide
new ARV units
(6 Total)

Contractor to provide
ARRA "approved"
materials.

- NOTES:
1. CONCRETE COLLAR IS ONLY REQUIRED IF MH IS NOT IN PAVEMENT. ALL CONCRETE SHALL BE POURED AGAINST UNDISTURBED EARTH.
 2. ROUTE TONING WIRE OUTSIDE OF ARV AND PROVIDE TONING WIRE VALVE BOX ADJACENT TO ARV STRUCTURE. SEE DETAIL S-4.10.
 3. PRECAST CONCRETE RISER SHALL BE 5' IN DIAMETER FOR PIPELINES 12 INCH AND GREATER WITH 30" HINGED FRAME AND COVER.

Provide
Lump Sum Quote: →
for
Change Order:

Contractor to remove existing ARV's and replace with
new ARV units and pipe appurtenances.

Line Item No. 3

(Alternative Check Valve Cost Credit)

Gilbert, Michael

From: Brad Hawkes <bhawkes@sussexcountyde.gov>
Sent: Monday, January 14, 2013 4:38 PM
To: Hinz, Will
Cc: Gilbert, Michael
Subject: RE: Pump Station 30

Please proceed

Brad

From: Hinz, Will [<mailto:WHinz@wrallp.com>]
Sent: Monday, January 14, 2013 10:11 AM
To: Brad Hawkes
Cc: Gilbert, Michael
Subject: FW: Pump Station 30

Brad,

We recommend accepting the Alternate check valve credit. With your concurrence we will respond to Bearing so they can get the valve on order.

Will

From: Jim Merrell [<mailto:Jim@bearingconstruction.net>]
Sent: Monday, January 14, 2013 10:06 AM
To: Hinz, Will
Cc: Gilbert, Michael
Subject: Pump Station 30

Will

Attached is the Check Valve Credit

James R Merrell
Bearing Construction
ph. 410-556-6100
fax. 410-556-6574



Bearing
Construction

The information supplied in this message may be privileged, confidential and/or exempt from disclosure under applicable law. If you are not the intended recipient of this message, the sender does not intend delivery to you to waive any privilege or right

Gilbert, Michael

From: Brad Hawkes <bhawkes@sussexcountye.gov>
Sent: Monday, January 14, 2013 4:38 PM
To: Hinz, Will
Cc: Gilbert, Michael
Subject: RE: Pump Station 30

Please proceed

Brad

From: Hinz, Will [<mailto:WHinz@wrallp.com>]
Sent: Monday, January 14, 2013 10:11 AM
To: Brad Hawkes
Cc: Gilbert, Michael
Subject: FW: Pump Station 30

Brad,

We recommend accepting the Alternate check valve credit. With your concurrence we will respond to Bearing so they can get the valve on order.

Will

From: Jim Merrell [<mailto:Jim@bearingconstruction.net>]
Sent: Monday, January 14, 2013 10:06 AM
To: Hinz, Will
Cc: Gilbert, Michael
Subject: Pump Station 30

Will

Attached is the Check Valve Credit

James R Merrell
Bearing Construction
ph. 410-556-6100
fax. 410-556-6574



Bearing
Construction

The information supplied in this message may be privileged, confidential and/or exempt from disclosure under applicable law. If you are not the intended recipient of this message, the sender does not intend delivery to you to waive any privilege or right

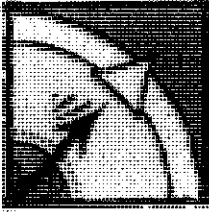

BEARING CONSTRUCTION, INC.

805 Shine Smith Road
Sudlersville, MD 21668
410/556-6100
410/556-6574

1/14/2013

Whitman, Requardt and Associates, LLP
21553 Rudder Lane
Georgetown, DE 19947

Project: South Coastal Regional Wastewater Facilities
P.S. #30 Improvements
Contract No. 09-17

Attn: Michael J. Gilbert

Re: PCO # 008
Check Valve Credit

Bearing is pleased to submit this PCO for changing the Check Valves.

Total Credit \$ (15,000.00)

Please see attached breakdown.

James Merrell
President



FERGUSON WATERWORKS #1835
 68 INDUSTRIAL PARK CIRCLE
 WALDORF, MD 20602-0068

Deliver To: justin.colton@ferguson.com
 From: Justin Colton
 Comments:

09:54:29 JAN 14 2013

FERGUSON WATERWORKS #1800

Page # 1

Price Quotation
 Phone : 301-870-7901
 Fax : 301-870-7909

Bid No.....: B244881
 Bid Date.....: 01/14/13
 Quoted By.: JPC

Cust 410-556-6064
 Terms.....: NET 10TH PROX

Customer: BEARING CONSTRUCTION INC
 S COASTAL RGNL WSTWTR PLNT
 805 SHINE SMITH ROAD
 SUDLERSVILLE, MD 21668

Ship To: BEARING CONSTRUCTION INC
 S COASTAL RGNL WSTWTR PLNT
 805 SHINE SMITH ROAD
 SUDLERSVILLE, MD 21668

Cust PO#...:

Job Name: SCWRP CHECK VALVE CH

Item	Description	Quantity	Net Price	UM	Total
	=====				
	NEW GA PACKAGE PRICE FOR				
	CHECKS W/ AIR CUSHIONS				
	=====				

SP-GA-250DS-16	16" 125# FLG OL&W AIR CUSH CHK S LS	4	0.000	EA	0.00
SP-GA-625D-8	8" 125# ANGL SWR SURGE RELIEF VLV	2	0.000	EA	0.00
	*****				62869.92
	GA AIR CUSH PACK PRICE				62869.92

	=====				

	OLD GA PACKAGE PRICE FOR				
	CHECKS W/ OIL CUSHIONS				
	=====				

SP-25DXH-16	16" 25DXH CUSH SWG CHK VLV W/ LS	4	0.000	EA	0.00
SP-625D-X	8" 625D SWR SURGE RELIEF VLV	2	0.000	EA	0.00
				-77869.92
	GA OIL CUSH PACK CREDIT				-77869.92

Net Total: \$-15000.00

No Tax

~~Tax \$-900.00~~

Freight: \$0.00

RFI No. 10?

Gilbert, Michael

From: Hinz, Will
Sent: Thursday, December 13, 2012 11:16 AM
To: Jim Merrell
Cc: Gilbert, Michael; Stubbs, Kenneth; Brad Hawkes
Subject: RE: PS#30 Valves
Attachments: 15120-01 Surge Relief Valve.pdf.pdf; 15060-11 Combination Air Valve.pdf.pdf; 15114-01 Plug Valves.pdf.pdf; 15116-01 Check Valve.pdf; Surge_Relief Valve Settings.pdf

Jim,

Please see the attached review submittals for the valves as well as the Surge Relief Settings requested. Everything has been approved with the exception of the check valve. We are requesting a valve substitution for the Check Valve. Based on discussions with the manufacturers rep for GA, the new valves should be half the cost as the original valves, but should not impact lead time. However, please review and submit for cost impacts. We can expedite the review and approval of the alternate valve as you can email us the submittal and we should be able to respond within a day or two.

Thanks,

Will

From: Jim Merrell [<mailto:Jim@bearingconstruction.net>]
Sent: Thursday, December 13, 2012 8:29 AM
To: Hinz, Will
Cc: Gilbert, Michael; Stubbs, Kenneth
Subject: PS#30

Will,

Can you provide me with the pressure settings for the pressure relief valve. Kenny Stubbs has a form that was left at our field office that he will fax over to you. Thanks

James R Merrell
Bearing Construction
ph. 410-556-6100
fax. 410-556-6574



Bearing
Construction

Line Item No. 4

("Zero Dollar" Contract Time Extension – 114 Calendar Days)



October 17th, 2013

Mr. Brad Hawkes
Sussex County Engineering Department
#2 The Circle
Georgetown, Delaware 19947

Re: South Coastal Regional Wastewater Facilities (SCRWF)
P.S. #30 Improvements
Contract No. 09-17

Dear Mr. Hawkes:

Whitman, Requardt and Associates, LLP (WR&A) has received and completed our review and analysis of Bearing Construction, Inc.'s (BCI's) October 15th, 2013 letter regarding their request for a (100) calendar day, time extension on the above referenced project. Please be reminded that the revised completion deadline on the 09-17 Contract (as recommended by WR&A regarding per BCI's November 7th, 2012 and March 27th, 2013 Contract time extension request letters) on the 09-17 Contract has been tentatively extended from April 1st, 2013 (original deadline) to April 15th, 2013.

In the October 15th, 2013 letter, BCI has requested that a (100) calendar extension be approved due to additional Sussex County Engineering Department (SCED) requested work regarding the replacement of faulty air release valves (ARV's) on the existing force main conveyance system immediately upstream and off of the P. S. #30 project site. Our review of BCI's "ARV", time extension claim is summarized below:

- I. **"Off-Site" Replacement of (7) Faulty ARV's (100 days):** The Contractor has requested (100) calendar days for the time needed by Sussex County Environmental Services/SCED to acquire/purchase (7) new ARV units and subsequent installation and force main testing by BCI's work forces that was not originally required by the plans and specifications for the 09-17 Contract.

April 16th thru July 24th, 2013: Based on our review of WR&A field inspection records, the Contractor could not effectively start/perform/complete the Contract added, ARV replacement work until the middle part of July, 2013. Most of the time requested by BCI is due to the time needed to (1) solicit/review Contract Change Order cost proposals, (2) to negotiate final costs and (3) to acquire/deliver the new (Sussex County purchased) ARV units to the project site. Review of WR&A field inspector's log reveals that required final testing of the impacted sections of existing force main was successfully completed on Wednesday, July 24th, 2013.

(Total Days Impact = 100 calendar days from April 16th, 2013 through July 24th, 2013)

Therefore, based upon the above referenced added ARV replacement work item(s), as well as, WR&A's field observed/verified data, WR&A suggests that consideration be given by Sussex County Engineering Department for an additional one hundred (100) calendar day, "zero dollar", time extension on the 09-17 Contract for the above referenced time period from April 16th through July 24th, 2013. If SCED supervisors agree with WR&A's position on this particular matter, the requested time extension can be included (and officially approved) as part of the Contract stipulated, Change Order process.

Please inform WR&A of your final decision on this matter so we can include this time extension as a separate "line item" on the soon to be processed, Change Order No. 2 – Final, Contract 09-17 "close-out", documents. A copy of this letter will be sent directly to Bearing Construction, Inc. for their records

Should you happen to have any questions pertaining to this matter, please feel free to contact our office.

Very truly yours,

Whitman, Requardt & Associates, LLP

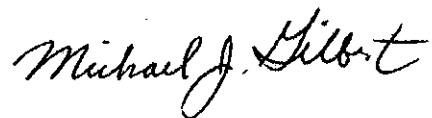

Michael J. Gilbert

Enclosure: BCI letter dated 3/27/13

cc: Michael A. Izzo, P.E. - (Sussex County Engineering Department)
Bobby Rogers - (Sussex County Engineering Department)
Rodney Marvel (Sussex County Environmental Services)
Chip Mayhew, P.E. - (U.S.D.A. – Rural Development)
Lisa Fitzgerald - (U.S.D.A. – Rural Development)
Jim Merrell - (Bearing Construction, Inc.)
Dennis J. Hasson, P.E. - (Whitman, Requardt and Associates)
Will F. Hinz, P.E. - (Whitman, Requardt and Associates)
Ken Stubbs - (Whitman, Requardt and Associates)
File No. 14207-003

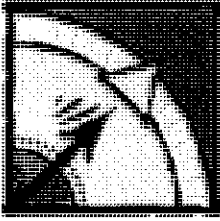

BEARING CONSTRUCTION, INC.

805 Shine Smith Road
Sudlersville, MD 21668

(410)556-6100

(410)556-6574 fax

www.bearingconstruction.net

10/15/2013

Michael J. Gilbert
WR&A Contract Administration
21553 Rudder Lane
Georgetown, Delaware

Contract No. 09-17
SCRWF P.S. #30 Improvements

Mr. Gilbert

Bearing Construction requests that a One Hundred day time extension be granted from April 16th, 2013 through July 24th, 2013 for the installation of the ARV's on the existing 18 inch force main. All cost for installation ARV's was approved on 7/19/2013 via email, for \$ 6,902.70. This time extension would result in a zero dollar change order to cover the time needed for the County to purchase the ARV's and the days needed by Bearing Construction to install them. Once the ARV's were installed Bearing was able to complete the start up operations for the Pump Station 30 Improvements Project (Contract 09-17).

James Merrell
President



March 27th, 2013

Mr. Brad Hawkes
Sussex County Engineering Department
#2 The Circle
Georgetown, Delaware 19947

Re: South Coastal Regional Wastewater Facilities (SCRWF)
P.S. #30 Improvements
Contract No. 09-17

Dear Mr. Hawkes:

Whitman, Requardt and Associates, LLP (WR&A) has received and completed our review and analysis of Bearing Construction, Inc.'s (BCI's) March 27th, 2013 letter regarding their request for a (9) calendar day, time extension on the above referenced project. Please be reminded that the revised completion deadline on the 09-17 Contract (as recommended by WR&A regarding per BCI's November 7th, 2012 Contract time extension request letter) on the 09-17 Contract has been tentatively extended from April 1st, 2013 (original deadline) to April 8th, 2013.

In the March 27th, 2013 letter, BCI has requested that a (9) calendar extension be approved primarily due to an adverse weather events encountered at the P. S. #30 project site during the months of January through March, 2013. Our review of BCI's "adverse weather, time extension claim is summarized below:

- I. **Adverse/Extreme Weather Event (7 days):** The Contractor has requested (9) calendar days for lost "production" or work days due numerous inclement weather events during the January 14th, 2013 work week, as well as, during the months of February and March, 2013.

January 1st thru January 23rd, 2013: Based on our review of our field inspection and local weather station records (Fenwick Island, Delaware), inclement rain/snow weather events directly impacted planned construction operations starting Monday, January 14th through Thursday, January 17th, 2013. In addition, two (2) additional working days were lost (Friday, January 18th and Saturday, January 19th) where the Contractor could not effectively work throughout the P. S. #30 project site due to the impacts of heavy precipitation and saturated soils.

(Total Days Impact = 7 calendar days from January 1st through January 23rd, 2013)

January 24th thru March 25th, 2013: In accordance with Specification Section 00810-12.03F, a potential Contract time delay may be claimed for "adverse weather conditions that cannot be reasonably anticipated" or weather events that go beyond what can be reasonably anticipated. It is WR&A's position that the inclement weather events of 1/24, 2/8, 2/11, 3/6, 3/12 and 3/25/13 do not go beyond normal weather events that can be reasonably anticipated for this time period and that the overall construction schedule was not adversely or significantly impacted.

21513 Rudder Lane, Georgetown, Delaware 19947 www.wrallp.com Phone: 302.855.9840 Fax: 302.855.9838

(Total Days Impact = 0 calendar days from January 24th through March 25th, 2013)

Therefore, based upon the above referenced, field observed and Rehoboth Beach, Delaware, weather station verified, weather data, WR&A suggests that consideration be given by Sussex County Engineering Department for an additional seven (7) calendar day, "zero dollar", time extension on the 09-17 Contract for the above referenced Monday, January 14th through Thursday, January 17th, 2013, "adverse weather event" item only. If this particular seven (7) calendar day time extension consideration is granted and approved by SCED officials, the Completion Date for Contract 09-17 will be changed from the tentative April 8th, 2013 date to April 15th, 2013. (Note: The "Hurricane Sandy" weather delay claim has been previously addressed under separate WR&A correspondence dated November 7th, 2012.)

Please inform us of your final decision on this matter so we can include this time extension as part of the next or the final close-out change order. A copy of this letter will be sent directly to Bearing Construction, Inc. for their records

Should you happen to have any questions pertaining to this matter, please feel free to contact our office.

Very truly yours,

Whitman, Requardt & Associates, LLP

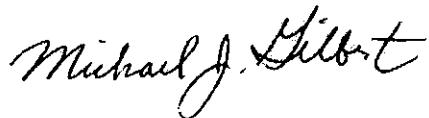

Michael J. Gilbert

Enclosure: BCI letter dated 3/27/13

cc: Michael A. Izzo, P.E. - (Sussex County Engineering Department)
Bobby Rogers - (Sussex County Engineering Department)
Rodney Marvel (Sussex County Environmental Services)
Chip Mayhew, P.E. - (U.S.D.A. - Rural Development)
Jim Merrell - (Bearing Construction, Inc.)
Dennis J. Hasson, P.E. - (Whitman, Requardt and Associates)
Will F. Hinz, P.E. - (Whitman, Requardt and Associates)
Ken Stubbs - (Whitman, Requardt and Associates)
File No. 14207-003



BEARING CONSTRUCTION, INC.

805 Shine Smith Road
Sudlersville, MD 21668

(410)556-6100

(410)556-6574 fax

www.bearingconstruction.net

3/27/2013

Michael J. Gilbert
WR&A Contract Administration
21553 Rudder Lane
Georgetown, Delaware

Contract No. 09-17
SCRWF P.S. #30 Improvements

Mr. Gilbert

Bearing Construction request a seven day time extension for the time lost due to the Hurricane Sandy weather event.

Bearing Construction also request a additional nine days for rain outs on the following dates;

1/15/2013
1/16/2013
1/17/2013
1/24/2013
2/08/2013
2/11/2013
3/06/2013
3/12/2013
3/25/2013

James Merrell
President



November 7th, 2012

Mr. Brad Hawkes
Sussex County Engineering Department
#2 The Circle
Georgetown, Delaware 19947

Re: South Coastal Regional Wastewater Facilities (SCRWF)
P.S. #30 Improvements
Contract No. 09-17

Dear Mr. Hawkes:

Whitman, Requardt and Associates, LLP (WR&A) has received and completed our review and analysis of Bearing Construction, Inc.'s (BCI's) November 7th, 2012 letter regarding their request for a (7) calendar day, time extension on the above referenced project. Please be reminded that the original/current completion deadline on the 09-17 Contract is April 1st, 2013.

In the November 7th, 2012 letter, BCI has requested that a (7) calendar extension be approved primarily due to an adverse or extreme weather event ("Hurricane Sandy") encountered during the backfill/excavation operations for the wet well and proposed valve vault structures at the P. S. #30 project site. Our review of BCI's "adverse/extreme weather, time extension claim is summarized below:

- I. Adverse/Extreme Weather Event (7 days): The Contractor has requested (7) calendar days for lost "production" or work days due to the adverse/extreme weather event identified as "Hurricane Sandy". Based on our review of our field inspection and local weather station records (Rehoboth Beach, Delaware), Hurricane Sandy directly impacted planned construction operations on both October 29th and 30th, 2012, "plus" 4 additional working days (Wednesday through Saturday) where the Contractor could not effectively work within the P. S. #30 project site due to the impacts of high wind, flooded drainage ditches and heavy rain.

October 29th/30th, 2012: High winds (60 mph +/-) and heavy rain (9.00" +/-) on these dates resulted in hazardous conditions at the P.S. #30 site where no productive work could be performed. A State of Delaware declared, Level II – State of Emergency also prohibited BCI forces from mobilizing to the project site.

October 31st thru November 3rd, 2012: The heavy rains of October 29th and 30th, 2012 resulted in extreme mud conditions and flooding within local drainage ditches where no productive work could be performed throughout the P.S. #30 project site.

(Total Days Impact = 7 calendar days from October 29th through November 4th, 2012)

Therefore, based upon the above referenced, field observed and Rehoboth Beach, Delaware, weather station verified, weather data, WR&A suggests that consideration be given by Sussex County Engineering Department for a seven (7) calendar day, "zero dollar", time extension on the 09-17 Contract for the above referenced "adverse weather event" item only. If this seven (7) calendar day time extension consideration is granted and approved by SCED officials, the Completion Date for Contract 09-17 will be changed from April 1st, 2013 to April 8th, 2013.

Please inform us of your final decision on this matter so we can include this time extension as part of the close-out change order. A copy of this letter will be sent directly to Bearing Construction, Inc. for their records

Should you happen to have any questions pertaining to this matter, please feel free to contact our office.

Very truly yours,

Whitman, Requardt & Associates, LLP

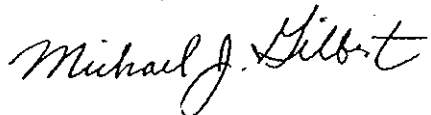

Michael J. Gilbert

cc: Michael A. Izzo, P.E. - (Sussex County Engineering Department)
Bobby Rogers - (Sussex County Engineering Department)
Rodney Marvel (Sussex County Environmental Services)
Chip Mayhew, P.E. - (U.S.D.A. - Rural Development)
Jim Merrell - (Bearing Construction, Inc.)
Dennis J. Hasson, P.E. - (Whitman, Requardt and Associates)
Will F. Hinz, P.E. - (Whitman, Requardt and Associates)
Ken Stubbs - (Whitman, Requardt and Associates)
File No. 14207-003

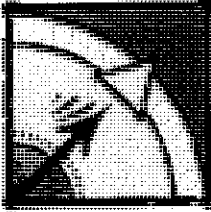

BEARING CONSTRUCTION, INC.

805 Shine Smith Road
Sudlersville, MD 21668
410/556-6100
410/556-6574

11/7/2012

Whitman, Requardt and Associates, LLP
21553 Rudder Lane
Georgetown, DE 19947

Project: South Coastal Regional Wastewater Facilities
P.S. #30 Improvements
Contract No. 09-17

Attn: Michael J. Gilbert

Re: PCO # 006
Hurricane Recovery

Bearing Construction is requesting a seven (7) day time extension for the Hurricane Sandy and the cleanup effort. The storm caused a stoppage of work for a complete week. Thanks for your consideration in this matter.

James Merrell
President

U.S. DEPARTMENT OF TRANSPORTATION
 FEDERAL AVIATION ADMINISTRATION
 AIRPORT IMPROVEMENT PROGRAM



CONTRACT CHANGE ORDER NO. 5 or SUPPLEMENTAL AGREEMENT NO
 AIRPORT SUSSEX COUNTY AIRPORT DATE 9/6/2013
 LOCATION GEORGETOWN, DE AIP PROJECT NO. 3-10-0007
 CONTRACTOR BUNTING AND MURRAY

You are requested to perform the following described work upon receipt of an approved copy of this document or as directed by the engineer:

Item No.	Description	Unit	Unit Price	Quantity	Amount
BALANCING CHANGE ORDER					
	Credit to original contract	LS	49,959.68	1	49,959.68
	Additional charges to original contract	LS	15,205.24	1	15,205.24

This Change Order Total \$(34,754.44)
 Previous Change Order(s) Total \$15,205.24
 Revised Contract Total \$386,600.52

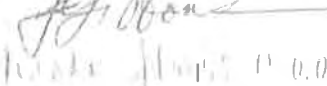
The time provided for completion in the contract is (unchanged) (decreased) (increased) by 0 working days. This document shall become an amendment to the contract and all provisions of the contract will apply. Changes are shown on Drawing(s) No. n/a dated n/a, three copies attached.

Recommended by:	Not Required		
	Engineer		Date
Approved by:	Owner		9/9/13 Date
Accepted by:	Contractor		(11/11)13 Date
Concurred by:	Not Required		Date
	State Aeronautics (if applicable)		Date
Approved by:	Required		Date
	Federal Aviation Administration		Date

NOTE: Change Orders and Supplemental Agreements require FAA approval prior to construction otherwise no Federal participation can be granted. State Aeronautics concurrence is required when state participation is anticipated.

AIP PROJECT NO. 3-10-0007

CHANGE ORDER NO. 5

(Supplemental Agreement)

AIRPORT SUSSEX COUNTY AIRPORT

LOCATION Georgetown, DE

JUSTIFICATION FOR CHANGE

1. Brief description of the proposed contract change(s) and location(s).
Balancing change order

2. Reason(s) for the change(s) (Continue on reverse if necessary)
See above

3. Justifications for unit prices or total cost.
See above

4. The sponsor's share of this cost is available from:
Sussex County

5. If this is a supplemental agreement involving more than \$2,000, is the cost estimate based on the latest wage rate decision: Yes No Not Applicable

6. Has consent of surety been obtained? Yes Not Necessary .

7. Will this change affect the insurance coverage? Yes No .

8. If yes, will the policies be extended? Yes No .

9. Has this (Change Order) (Supplemental Agreement) been discussed with FAA officials?
Yes No When _____ With Whom _____

Comment _____

Submit 4 copies to the FAA

09/09/13

To: Juel Gibbons

From: Renda Wise

The Final Contract amount we have is \$386,600.52 as follows:

Original Contract:		\$420,813.00
CO #1: Weed Whacking & String Line Trimming Pods A,B,C,&D July 2012	\$6,682.23	
CO#2: Re-Flagging of Shrubs July 2012	\$1,542.35	
CO#3: String Lined/Mowed Pods A,B,C,&D August 2012	\$6,980.66	
Add for A-12 Add'l .17 Acre Ernst Seeding:	\$391.34	
Add for A-15 Add'l .17 Acre Mulching:	\$150.62	
Total Adds to Original Contract:		\$15,747.20
Less Work Not Required as Follows:		
A-1 932.3 cy of Excavation & Embankment	-\$2,162.94	
A-2 400 cy of Type C Select	-\$3,576.00	
A-3 15% of Erosion & Sediment Control	-\$2,311.80	
A-4 1,250 lf Silt Fence	-\$1,787.50	
A-13 1.5 Acre Seeding	-\$2,020.50	
A-14 3.44 Acres Topsolling	-\$17,698.94	
A-16 Extra Dewatering by DNREC Permit per Pod	-\$8,802.00	
B-19 Add'l Excavation	-\$11,600.00	
Total Credit to Original Contract:		-\$49,959.68
Ending Contract Total:		<u>\$386,600.52</u>

Payments Received:

Last 6 Digits of Check #	Payment Amount	Date Received
133801	\$ 36,820.09	04/24/12
134846	\$ 116,779.69	05/29/12
135673	\$ 121,363.51	06/29/12
100027	\$ 35,623.40	07/16/12
101026	\$ 7,813.35	08/27/12
102113	\$ 6,631.63	10/18/12
103737	\$ 20,882.29	12/27/12
107533	\$ 21,356.53	05/30/13

Payments Received: \$ 367,270.49

Balance Due as of 09/09/13: \$ 19,330.03



**SUSSEX COUNTY
CHANGE ORDER REQUEST**

A. ADMINISTRATIVE

1. Project Name: **GREENWOOD LIBRARY**
2. Sussex County Contract No. 07-05
3. Change Order No. 2
4. Date Change Order Initiated 10/28/2013
5.
 - a. Original Contract Sum \$2,768,572.00
 - b. Net Change by Previous Change Orders \$5,110.36
 - c. Contract Sum Prior to Change Order \$2,773,682.36
 - d. Requested Change \$221.45
 - e. Net Change (No. of days) -
 - f. New Contract Amount \$2,773,903.81
6. Sussex County Contact Person Michael A. Izzo, P.E.
Telephone (302) 855-7718

B. REASONS FOR CHANGE ORDER

1. Differing Site Conditions
2. Errors and Omissions in Construction Drawings and Specifications
3. Changes Instituted by Regulatory Requirements
4. Design Change
5. Overrun/Underrun in Quantity
6. Factors Affecting Time of Completion

7. Other (explain below)

C. **BRIEF DESCRIPTION OF CHANGE ORDER**

Changes proposed to improve the final quality of the project.

D. **JUSTIFICATION FOR CHANGE ORDER INCLUDED?**

Yes No

E. **APPROVALS**

1. Richard Y. Johnson & Son, Inc., Project General Contractor

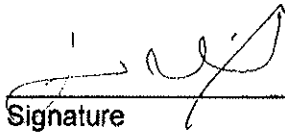
 _____
Signature Date 10/31/13

Jesse L. Dixon
Representative's Name in Block Letters

2. Sussex County Engineer

Signature Date

3. Davis, Bowen & Friedel, Inc., Project Consultant

Signature Date

GREENWOOD LIBRARY CHANGE ORDER #2		Original Contract Amount		\$	2,768,572.00	
		Change Order #1		\$	5,110.36	
DESCRIPTION	DEBIT	CREDIT	DAYS	\$	2,773,682.36	Net Chg. To Contract Amt.
Eliminate Magazine racks at Circ Desk; Add decorative panels		\$ (1,075.00)	-	\$	2,772,607.36	\$ (1,075.00)
Add snow guards to entrance canopy	\$ 594.00		-	\$	2,773,201.36	\$ (481.00)
Add Suspended ceiling teen services room	\$ 702.45		-	\$	2,773,903.81	\$ 221.45
Add USG 401 trim at exterior of building	\$ -		-	\$	2,773,903.81	\$ 221.45
					Change Order #2 Amount	\$ 221.45

P.O. Box 105
 LINCOLN, DELAWARE 19960
 (302) 422-3732
 (302)422-4696 fax

Change Order Proposal 11

Job Phone	Date	September 19, 2013
Job Location:		
Greenwood Public Library		
Greenwood, Delaware		
Job Number:	Architect:	
DBF # 1897B003	Davis, Bowen & Friedel, Inc.	

TO:

Sussex County
2 The Circle
Georgetown, Delaware 19947

We hereby submit specifications and estimates for:

Eliminate Magazine racks at Circulation Desk and Add decorative panels in their place	
Eliminate Magazine Racks at Circulation Desk	-\$4,000.00
Add decorative panels to front of Circulation Desk	\$2,925.00
Total:	- \$1,075.00

For the Sum of: Deduct One Thousand and Seventy-Five Dollars & 00 Cents - \$ 1,075.00

All material is guaranteed to be as specified. All work to be completed in a workmanlike manner according to standard industry practices. Any alteration or deviation from the above specifications involving extra cost will be executed only upon written orders, and will become an extra charge over and above the estimate. All agreements contingent upon strikes, accidents or delays beyond our control. Owner to carry fire, tornado and other necessary insurance. Our workers are fully covered by Workman's Compensation Insurance. This proposal may be withdraw by us if not accepted within Thirty (30) days.

Accepted By: _____
 Date: _____ Jesse Dixon – Project Manager



CABINETS • COUNTERTOPS • TILE

PO BOX 687, SELBYVILLE, DE 19975

Phone: 302-436-8696 Fax: 302-436-5031

**** CHANGE ORDER ****

Name: Jesse Dixon
Company: Richard Y Johnson
Address: 18404 Johnson Road
Lincoln, DE

Date: 9/19/2013
Job: Greenwood Public Library
Location: Greenwood, DE

Subject: Elimination Mag. Racks

Sales Order #:

Contact: Jesse Dixon

Contract Date:

Phone: 302-422-3732

Revised Drawings Attached:

The following items have been changed, amended, deleted, added or selected:

Description of work: Eliminate Magazine racks at Circulation desk. Add decorative panels in their place.

Table with 4 columns: Description, Qty, Price/Unit, Total. Row 1: Eliminate Magazine Racks at Circulation desk, 1, \$ (4,000.00), \$ (4,000.00). Row 2: Add decorative panels to fron of Circ. Desk, 1, \$ 2,925.00, \$ 2,925.00.

Tax: 0%
Labor: 0 dollars \$ -

The above changes have affected the previously executed executed contract by:

one thousand seventy five 00/100 CREDIT dollars \$ (1,075.00)

CABINETERY UNLIMITED (with signature)

ACCEPTANCE OF CHANGE ORDER: The prices and changes set forth above are satisfactory and are hereby accepted. Cabinetry Unlimited LLC is authorized to perform the work as specified. Payment will be made according to contract term. Prices are valid for 30 days.

CUSTOMER SIGNATURE

DATE OF ACCEPTANCE

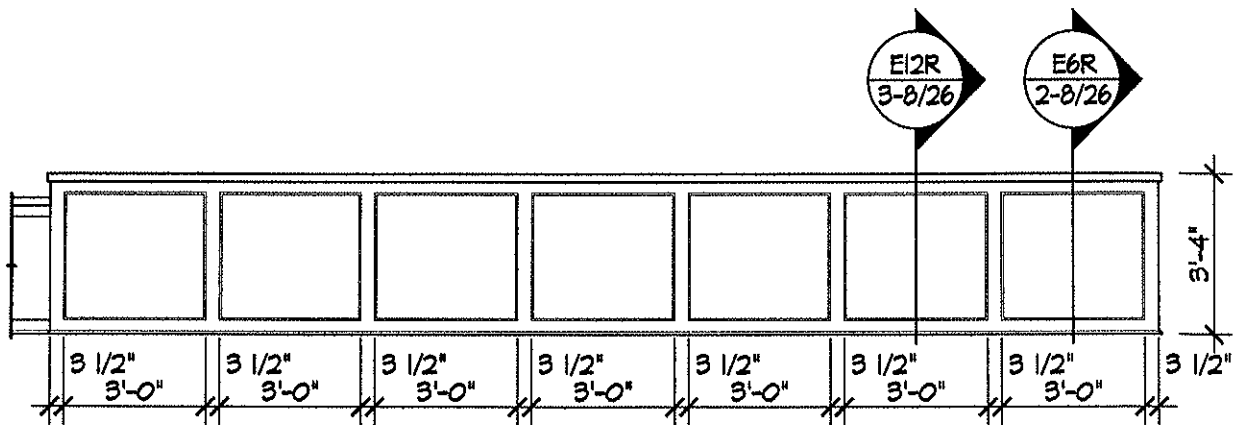

16R

CIRCULATION/INFORMATION - 123

1/4" = 1'-0"



DAVIS
BOWEN &
FRIEDEL, INC.

ARCHITECTS, ENGINEERS & SURVEYORS
SALISBURY, MARYLAND ■ MILFORD, DELAWARE
410.543.9091 302.424.1441

GREENWOOD PUBLIC LIBRARY
100 MILL STREET
GREENWOOD, DELAWARE

MODIFIES DET 16/A8.2

Date: 8/26/13

Scale: NOTED

Proj.No.: 1897B003

COPYRIGHT © 2013

Dwg.No.: .

1-8/26

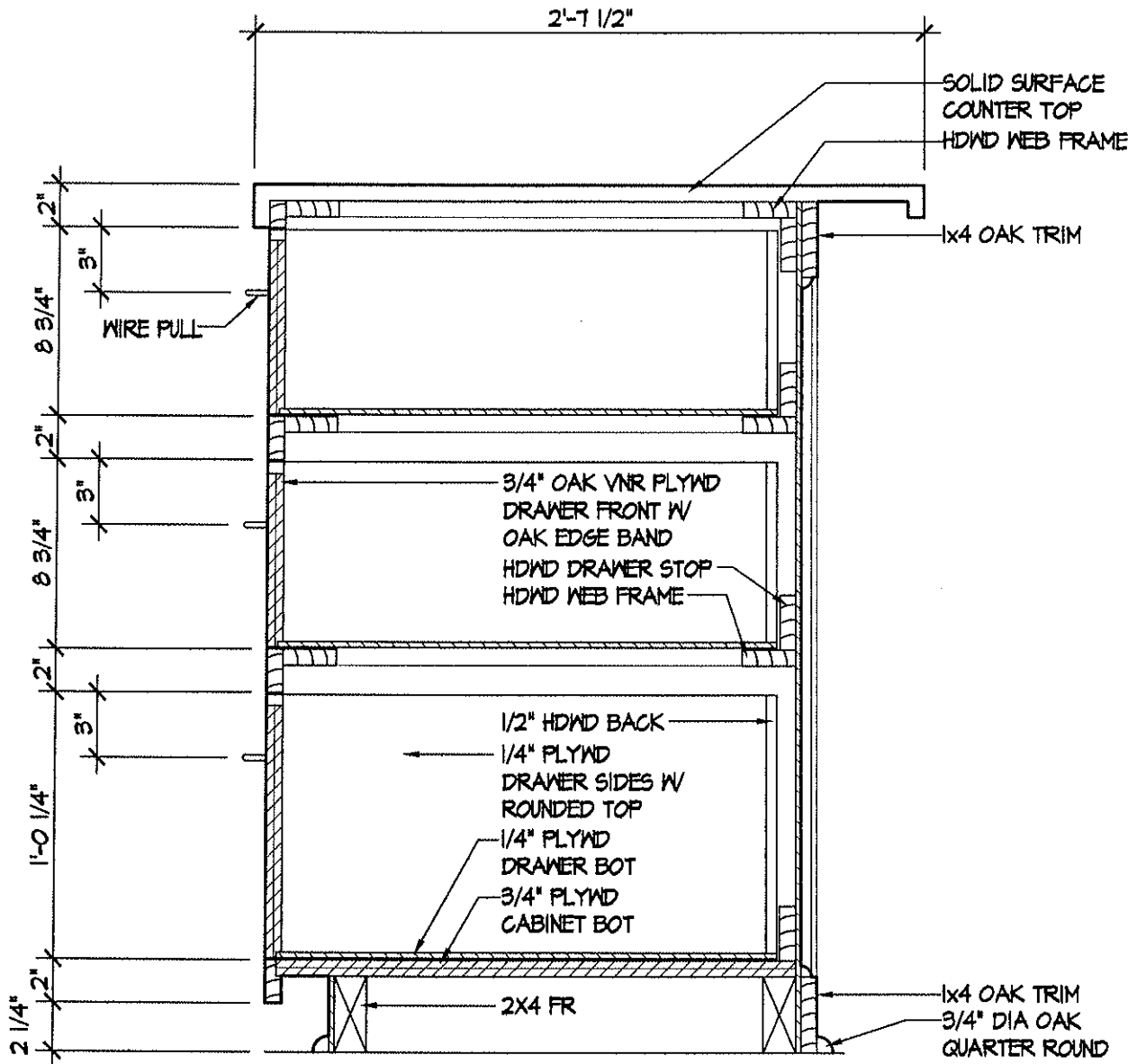

E6R

CABINET @ CIR/INFO -123

1 1/2" = 1'-0"



DAVIS
BOWEN &
FRIEDEL, INC.

ARCHITECTS, ENGINEERS & SURVEYORS
SALISBURY, MARYLAND ■ MILFORD, DELAWARE
410.543.9091 302.424.1441

GREENWOOD PUBLIC LIBRARY
100 MILL STREET
GREENWOOD, DELAWARE

COPYRIGHT © 2013

Dwg.No.:

2-8/26

MODIFIES DET E6/A8.4

Date: 8/26/13

Scale: NOTED

Proj.No.: 1897B003

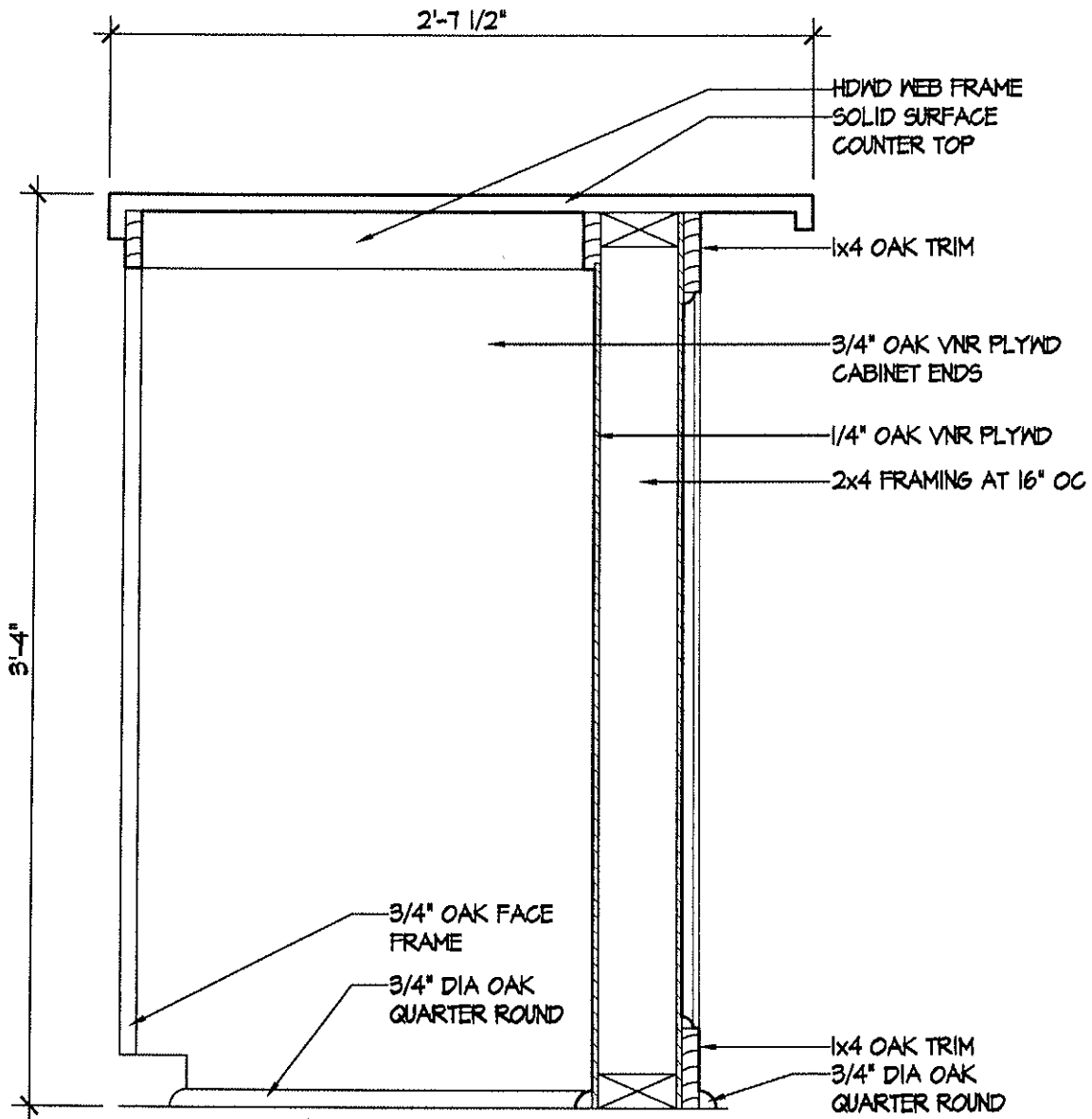

E12R

COUNTER @ CIR/INFO -123

1 1/2" = 1'-0"



DAVIS
BOWEN &
FRIEDEL, INC.

ARCHITECTS, ENGINEERS & SURVEYORS
SALISBURY, MARYLAND ■ MILFORD, DELAWARE
410.543.9091 302.424.1441

GREENWOOD PUBLIC LIBRARY
100 MILL STREET
GREENWOOD, DELAWARE

MODIFIES DET E12/A84

Date: 8/26/13

Scale: NOTED

Proj.No.: 1897B003

COPYRIGHT © 2013

Dwg.No.:

3-8/26

Change Order Proposal 12

Job Phone	Date	September 20, 2013
Job Location:		
Greenwood Public Library		
Greenwood, Delaware		
Job Number:	Architect:	
DBF # 1897B003	Davis, Bowen & Friedel, Inc.	

TO:

Sussex County
 2 The Circle
 Georgetown, Delaware 19947

We hereby submit specifications and estimates for:

Add additional 10' of Snow Guards on Entrance Canopy	
10' Snow Guard Labor	\$352.50
10' Snow Guard Material	\$187.50
Subtotal	\$ 540.00
RYJ (10% OH&P)	\$54.00
Total:	\$594.00

For the Sum of: <u>Five Hundred & Ninety-Four Dollars & 00 Cents</u>	<u>\$594.00</u>
<p>All material is guaranteed to be as specified. All work to be completed in a workmanlike manner according to standard industry practices. Any alteration or deviation from the above specifications involving extra cost will be executed only upon written orders, and will become an extra charge over and above the estimate. All agreements contingent upon strikes, accidents or delays beyond our control. Owner to carry fire, tornado and other necessary insurance. Our workers are fully covered by Workman's Compensation Insurance. This proposal may be withdraw by us if not accepted within Thirty (30) days.</p>	
Accepted By: _____	_____
Date: _____	Jesse Dixon -- Project Manager

BUILDING CONCEPTS OF AMERICA, INC.

101 Peoples Drive Newark Industrial Park Newark, DE 19702 302-292-0200 Fax: 302-456-1251

September 20, 2013

Richard Y. Johnson & Son, Inc.
18404 Johnson Rd.
P.O. Box 105
Lincoln, DE 19960
Attn: Jesse Dixon

Re: Greenwood Library / TEN FOOT ONLY ColorGard Snow Guards on Entrance Canopy

Dear Jesse,

As was requested BCA respectfully submits this change order proposal for the owners' review and consideration. BCA offers to furnish and install TEN FOOT of ColorGard Snow Guards on the entrance canopy standing seam metal roof system. The ColorGard system is per spec and will be installed according to the prevailing wage rates per contract as follows.

- ColorGard Snow Guard with S5 clamps on 16" centers and 1 SnoClip III per pan.
- 2" Color Strips as "Brownstone" included to match roof system per spec.
- Freight to the jobsite and unloading included.
- Installation per prevailing wage rates and project specs per manufacturer's instructions.
- Priced as requested TEN FOOT ONLY of canopy length.

LABOR AT PREVAILING WAGE PER CONTRACT = \$352.50
MATERIALS PER APPROVED PRODUCT = 10' 0" = \$187.50
TOTAL LUMP SUM INSTALLED = Five Hundred Forty Dollars and Zero Cents
= \$540.00 ADD to Contract.

Thanks for your time and efforts and please let me know how we should proceed.

Sincere regards,

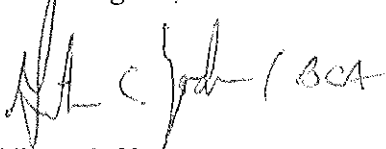

Gibson C. Yoder
Construction Sales

Julie Cooper

From: Chris Cullen <clc@dbfinc.com>
Sent: Tuesday, September 10, 2013 4:10 PM
To: 'Jesse Dixon'
Cc: Julie Cooper
Subject: GPL Snow Guards

Jesse,

Please revise the scope of work for RYJ Change Order Proposal # 10 as follows:

1. Please provide 10' feet of Snow Guard per the specifications to be located in the field as directed by the Architect.
2. The purpose of the snow guard will be to protect the large gutter on the lower roof that will be exposed to snow falling off the canopy roof.

Thank you,

Christopher Lee Cullen AIA | Associate | Salisbury Office
One Plaza East, Suite 200 | Salisbury, MD 21801 | www.dbfinc.com
Office: 410-543-9091 | Fax: 410-543-4172 | Email: clc@dbfinc.com



P.O. Box 105
 LINCOLN, DELAWARE 19960
 (302) 422-3732
 (302)422-4696 fax

Change Order Proposal 13

Job Phone	Date	October 30, 2013
Job Location:		
Greenwood Public Library		
Greenwood, Delaware		
Job Number:	Architect:	
DBF # 1897B003	Davis, Bowen & Friedel, Inc.	

TO:

Sussex County

 2 The Circle

 Georgetown, Delaware 19947

We hereby submit specifications and estimates for:

Add suspended Ceiling in Teen Services Room due to ductwork and complex roof.	
Suspended Ceiling (See attached Master Acoustical Quote)	\$1659.00
Deduct Painting above 9' height in walls and ceiling (See attached M&S)	-\$990.00
Level 5 finish fro Drywall (substituted add USG trim)	\$0.00
Subtotal	\$ 669.00
RYJ (5% OH&P)	\$33.45
Total:	\$702.45

For the Sum of: <u>Seven Hundred & Two Dollars & 45 Cents</u>	<u>\$702.45</u>
All material is guaranteed to be as specified. All work to be completed in a workmanlike manner according to standard industry practices. Any alteration or deviation from the above specifications involving extra cost will be executed only upon written orders, and will become an extra charge over and above the estimate. All agreements contingent upon strikes, accidents or delays beyond our control. Owner to carry fire, tornado and other necessary insurance. Our workers are fully covered by Workman's Compensation Insurance. This proposal may be withdraw by us if not accepted within Thirty (30) days.	
Accepted By: _____	_____
Date: _____	Jesse Dixon – Project Manager

Master Acoustical, Inc.

158 Mullet Run
Milford, Delaware 19963
(302) 424-3744
FAX (302) 424-3749

CHANGE ORDER FAX SHEET

To: Jesse Dixon Company: CM-Richard Y Johnson
Project: Greenwood Library Date Due: _____
From: Lyle Humpton Pages Faxed: _____
Date: 10/30/13

Change Order Price: \$1,659

Specification Section(S): Acoustical ceilings: same material as already approved

Addendums: NA

Exclusions/Additions:

Price to supply and install acoustical ceilings in Teen Services room per your email. No ceilings to be installed in Youth Program Room.

Material: \$961

Labor: \$547

Total: \$1,508

10%: \$151

Total change order: \$1,659

M & S PAINTING, INC.

Custom Painting & Wall Covering

P.O. BOX 6137
WILMINGTON, DE 19804

Phone 302-995-2623
Fax 302-998-2420
mspinters@aol.com

BID / PROPOSAL FORM

TO:	FROM:
Jessie Dixon	James C. McElroy, Jr.
COMPANY:	DATE:
R.Y. Johnson, Inc.	10/01/12
PROJECT:	TOTAL PAGES INCLUDING COVER:
Greenwood Public Library	One
BID AS RATED PROJECT	READ – Five (5) ADDENDUM(S)

Credit: Painting Expos. Ceiling & Walls in Teen Services Rm 121

Deduct BASE BID \$ 990.00

Credit PRICE INCLUDES: **Painting Drywall Walls & Exposed Ceiling**
Bid Using: 1 Primer Ct & 2 Finish CT's thru out.
All Labor & Material

Julie Cooper

From: Chris Cullen <clc@dbfinc.com>
Sent: Tuesday, August 20, 2013 9:12 AM
To: 'Jesse Dixon'
Cc: Julie Cooper
Subject: Greenwood Public Library
Attachments: 8-20 TRIM CO.pdf

Jesse;

Please develop a cost proposal for the attached sketch adding the USG Galvanized 410 Trim to cover the edge of the exterior gypsum sheathing at the metal siding only, this is not required at the brick veneered walls.

Thank you,

Christopher Lee Cullen AIA | Associate | Salisbury Office
One Plaza East, Suite 200 | Salisbury, MD 21801 | www.dbfinc.com
Office: 410-543-9091 | Fax: 410-543-4172 | Email: clc@dbfinc.com

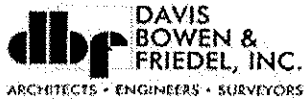

USG GALVANIZED
401 TRIM OR EQUAL

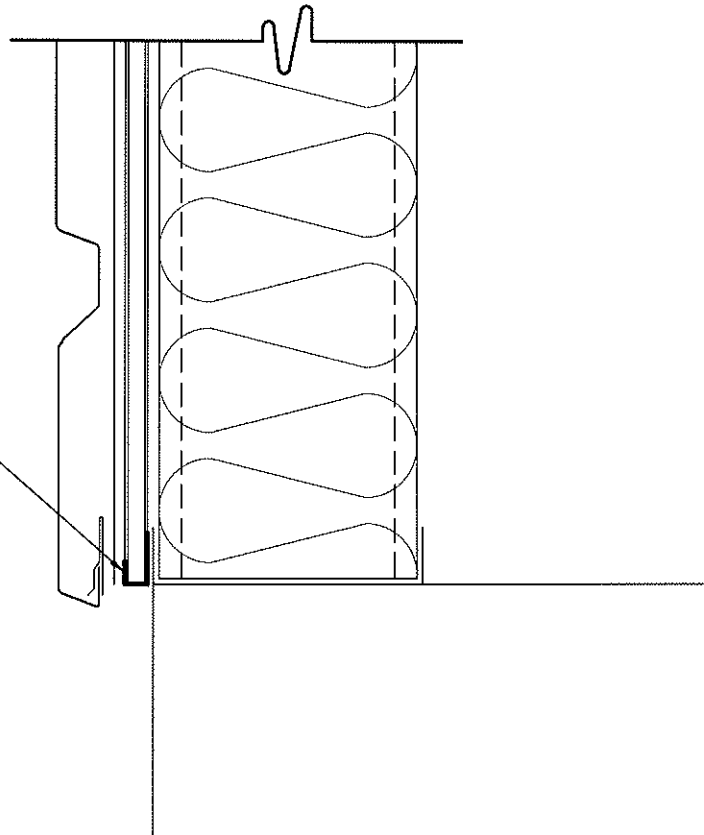

PARTIAL SECTION

3"=1'-0"



DAVIS
BOWEN &
FRIEDEL, INC.

ARCHITECTS, ENGINEERS & SURVEYORS
SALISBURY, MARYLAND ■ MILFORD, DELAWARE
410.543.9091 302.424.1441

GREENWOOD PUBLIC LIBRARY
100 MILL STREET
GREENWOOD, DELAWARE

COPYRIGHT © 2008

Dwg.No.:

8-20

1 OF 1

Date: 8/20/13

Scale: NOTED

Proj.No.: 1897B003



Sussex County Council
2 The Circle
P.O. Box 589
Georgetown, DE 19947

Re: Grant Request

Dear County Council:

We are writing to you today to ask for your assistance with purchasing hay for the winter. Normally, we receive several donations of hay each year. This year however we only received approximately 2% of the usual amount. That has left us to purchase basically all the hay we needed this year. We are currently trying to purchase as much hay as we can before winter sets in and the price of hay skyrockets.

We were able to purchase a large parcel of land at the end of 2012. We have separated half of the pasture land to enable us to disk, fertilize and plant seed. This is a slow process, but we will eventually be able to practice excellent pasture management and the need for hay will be reduced over time.

If you have any questions or need more information, please do not hesitate to contact me.

Sincerely,

Robin Weinkam

Changing Fates Equine Rescue of Delaware, Inc.

ORDINANCE NO. ____

AN ORDINANCE TO AMEND THE COMPREHENSIVE ZONING MAP OF SUSSEX COUNTY FROM AN AR-1 AGRICULTURAL RESIDENTIAL DISTRICT TO A CR-1 COMMERCIAL RESIDENTIAL DISTRICT FOR A CERTAIN PARCEL OF LAND LYING AND BEING IN LITTLE CREEK HUNDRED, SUSSEX COUNTY, CONTAINING 16,150 SQUARE FEET, MORE OR LESS (Tax Map I.D. 3-32-1.08-39.00)

WHEREAS, on the 13th day of October 2013, a zoning application, denominated Change of Zone No. 1739 was filed on behalf of Vance Phillips; and

WHEREAS, on the ____ day of _____ 2013, a public hearing was held, after notice, before the Planning and Zoning Commission of Sussex County and said Planning and Zoning Commission recommended that Change of Zone No. 1739 be _____; and

WHEREAS, on the ____ day of _____ 2013, a public hearing was held, after notice, before the County Council of Sussex County and the County Council of Sussex County has determined, based on the findings of facts, that said change of zone is in accordance with the Comprehensive Development Plan and promotes the health, safety, morals, convenience, order, prosperity and welfare of the present and future inhabitants of Sussex County,

NOW, THEREFORE,

THE COUNTY OF SUSSEX HEREBY ORDAINS:

Section 1. That Chapter 115, Article II, Subsection 115-7, Code of Sussex County, be amended by deleting from the Comprehensive Zoning Map of Sussex County the zoning classification of [AR-1 Agricultural Residential District] and adding in lieu thereof the designation CR-1 Commercial Residential District as it applies to the property hereinafter described.

Section 2. The subject property is described as follows:

ALL that certain tract, piece or parcel of land lying and being situate in Little Creek Hundred, Sussex County, Delaware, and lying at the northwest corner of U.S. Route 13 and Route 24 and being more particularly described as Tract No. 5 in Deed Book 4170, Page 89 as recorded in the Office of the Recorder of Deeds in and for Sussex County, excepting that portion of the property dedicated to public use for the right-of-way and intersection improvements for the intersection of U.S. Route 13 and Route 24; and as identified on the Sussex County Tax Map as District 3-32 Map 1.08 Parcel 39.00. Said parcel

containing 16,150 square feet, more or less.

This Ordinance shall take effect immediately upon its adoption by majority vote of all members of the County Council of Sussex County, Delaware.

PROPOSED

ORDINANCE NO. ____

AN ORDINANCE TO AMEND THE COMPREHENSIVE ZONING MAP OF SUSSEX COUNTY FROM AN AR-1 AGRICULTURAL RESIDENTIAL DISTRICT TO A CR-1 COMMERCIAL RESIDENTIAL DISTRICT FOR A CERTAIN PARCEL OF LAND LYING AND BEING IN BROADKILL HUNDRED, SUSSEX COUNTY, CONTAINING 2.3522 ACRES, MORE OR LESS (Tax Map I.D. 2-35-16.00-64.00)

WHEREAS, on the 25th day of September 2013, a zoning application, denominated Change of Zone No. 1740 was filed on behalf of Zhenguo Zhang; and

WHEREAS, on the ____ day of _____ 2013, a public hearing was held, after notice, before the Planning and Zoning Commission of Sussex County and said Planning and Zoning Commission recommended that Change of Zone No. 1740 be _____; and

WHEREAS, on the ____ day of _____ 2013, a public hearing was held, after notice, before the County Council of Sussex County and the County Council of Sussex County has determined, based on the findings of facts, that said change of zone is in accordance with the Comprehensive Development Plan and promotes the health, safety, morals, convenience, order, prosperity and welfare of the present and future inhabitants of Sussex County,

NOW, THEREFORE,

THE COUNTY OF SUSSEX HEREBY ORDAINS:

Section 1. That Chapter 115, Article II, Subsection 115-7, Code of Sussex County, be amended by deleting from the Comprehensive Zoning Map of Sussex County the zoning classification of [AR-1 Agricultural Residential District] and adding in lieu thereof the designation CR-1 Commercial Residential District as it applies to the property hereinafter described.

Section 2. The subject property is described as follows:

ALL that certain tract, piece or parcel of land lying and being situate in Broadkill Hundred, Sussex County, Delaware, and lying southwest of Route One (Coastal Highway) 1,000 feet northwest of Road 258 (Hudson Road) and being more particularly described in Deed Book 4164, Page 308 in the Office of the Recorder of Deeds in and for Sussex County, said parcel containing 2.3522 acres, more or less.

This Ordinance shall take effect immediately upon its adoption by majority vote of all members of the County Council of Sussex County, Delaware.

ORDINANCE NO. ____

AN ORDINANCE TO GRANT A CONDITIONAL USE OF LAND IN AN AR-1 AGRICULTURAL RESIDENTIAL DISTRICT FOR AUTO REPAIR AND SALES TO BE LOCATED ON A CERTAIN PARCEL OF LAND LYING AND BEING IN CEDAR CREEK HUNDRED, SUSSEX COUNTY, CONTAINING 1.06 ACRES, MORE OR LESS (Tax Map I.D. 3-30-15.00-20.01)

WHEREAS, on the 10th day of October 2013, a conditional use application, denominated Conditional Use No. 1975 was filed on behalf of Ronald and Susan Berwick; and

WHEREAS, on the ____ day of _____ 2013, a public hearing was held, after notice, before the Planning and Zoning Commission of Sussex County and said Planning and Zoning Commission recommended that Conditional Use No. 1975 be _____; and

WHEREAS, on the ____ day of _____ 2013, a public hearing was held, after notice, before the County Council of Sussex County and the County Council of Sussex County determined, based on the findings of facts, that said conditional use is in accordance with the Comprehensive Development Plan and promotes the health, safety, morals, convenience, order, prosperity and welfare of the present and future inhabitants of Sussex County, and that the conditional use is for the general convenience and welfare of the inhabitants of Sussex County.

NOW, THEREFORE, THE COUNTY OF SUSSEX HEREBY ORDAINS:

Section 1. That Chapter 115, Article IV, Subsection 115-22, Code of Sussex County, be amended by adding the designation of Conditional Use No. 1975 as it applies to the property hereinafter described.

Section 2. The subject property is described as follows:

ALL that certain tract, piece or parcel of land, lying and being situate in Cedar Creek Hundred, Sussex County, Delaware, and lying east of Road 225 (Marshall Street) 2,767 feet north of Road 207 (Johnson Road) and north of Jumping Jack Lane more particularly described as Lot 2 in Plot Book 121, Page 152 as recorded in the Office of the Recorder of Deeds in and for Sussex County, Delaware, said parcel containing 1.06 acres, more or less.

This Ordinance shall take effect immediately upon its adoption by majority vote of all members of the County Council of Sussex County, Delaware.

ORDINANCE NO. ____

AN ORDINANCE TO GRANT A CONDITIONAL USE OF LAND IN AN AR-1 AGRICULTURAL RESIDENTIAL DISTRICT FOR AN ELEMENTARY SCHOOL EXPANSION TO BE LOCATED ON A CERTAIN PARCEL OF LAND LYING AND BEING IN DAGSBORO HUNDRED, SUSSEX COUNTY, CONTAINING 26.77 ACRES, MORE OR LESS (Tax Map I.D. 1-33-17.00-41.00 and 42.00)

WHEREAS, on the 21st day of October 2013, a conditional use application, denominated Conditional Use No. 1976 was filed on behalf of Indian River School District; and

WHEREAS, on the ____ day of _____ 2013, a public hearing was held, after notice, before the Planning and Zoning Commission of Sussex County and said Planning and Zoning Commission recommended that Conditional Use No. 1976 be _____; and

WHEREAS, on the ____ day of _____ 2013, a public hearing was held, after notice, before the County Council of Sussex County and the County Council of Sussex County determined, based on the findings of facts, that said conditional use is in accordance with the Comprehensive Development Plan and promotes the health, safety, morals, convenience, order, prosperity and welfare of the present and future inhabitants of Sussex County, and that the conditional use is for the general convenience and welfare of the inhabitants of Sussex County.

NOW, THEREFORE, THE COUNTY OF SUSSEX HEREBY ORDAINS:

Section 1. That Chapter 115, Article IV, Subsection 115-22, Code of Sussex County, be amended by adding the designation of Conditional Use No. 1976 as it applies to the property hereinafter described.

Section 2. The subject property is described as follows:

ALL that certain tract, piece or parcel of land, lying and being situate in Dagsboro Hundred, Sussex County, Delaware, and lying southwest of Road 331 (Iron Branch Road) 1,200 feet southeast of Road 339 (Old Landing Road) and northwest of 1st Street in Riverview Subdivision more particularly described as:

BEGINNING at a point at the northwest corner of Road 331 (Iron Branch Road) and 1st Street, a 30 foot width right-of-way in Riverview Subdivision; thence south 24°44'09" west 502.81 feet along said 1st Street to a point; thence north 63°19'51" west 154.01 feet along lands of Ralph Drummond to a point; thence northwesterly and easterly the following eight (8) courses; south 51°47'41" west 454.88 feet to a point; south 88°18'47" west 320.12 feet to a

point; north 26°25'23" west 697.00 feet to a point; north 41°42'33" west 54.51 feet to a point; north 25°22'46" west 168.67 feet to a point; north 24°24'41" west 84.66 feet to a point; north 49°34'11" east 440.30 feet to a point; and north 48°02'39" east 337.02 feet to a point on the southwesterly right-of-way of Road 331; thence southeasterly 20 feet along Road 331 to a point, a corner for lands, now or formerly, of David C. and Jamie F. Doane; thence following said Doane lands the following three (3) courses: south 47°55'06" west 323.96 feet to a point; south 37°25'02" east 79.97 feet to a point; and north 48°00'42" east 347.66 feet to a point on the southwesterly right-of-way of Road 331; thence southeasterly 1,050.03 feet along the southwesterly right-of-way of Road 331 to the point and place of beginning. Said parcel containing 26.77 acres, more or less.

This Ordinance shall take effect immediately upon its adoption by majority vote of all members of the County Council of Sussex County, Delaware.

PROPOSED

ORDINANCE NO. ____

AN ORDINANCE TO GRANT A CONDITIONAL USE OF LAND IN AN AR-1 AGRICULTURAL RESIDENTIAL DISTRICT FOR A DOCTORS OFFICE TO BE LOCATED ON A CERTAIN PARCEL OF LAND LYING AND BEING IN INDIAN RIVER HUNDRED, SUSSEX COUNTY, CONTAINING 8,276 SQUARE FEET, MORE OR LESS (Tax Map I.D. 2-34-32.00-9.00)

WHEREAS, on the 24th day of October 2013, a conditional use application, denominated Conditional Use No. 1977 was filed on behalf of Matthew T. Favinger; and

WHEREAS, on the ____ day of _____ 2013, a public hearing was held, after notice, before the Planning and Zoning Commission of Sussex County and said Planning and Zoning Commission recommended that Conditional Use No. 1977 be _____; and

WHEREAS, on the ____ day of _____ 2013, a public hearing was held, after notice, before the County Council of Sussex County and the County Council of Sussex County determined, based on the findings of facts, that said conditional use is in accordance with the Comprehensive Development Plan and promotes the health, safety, morals, convenience, order, prosperity and welfare of the present and future inhabitants of Sussex County, and that the conditional use is for the general convenience and welfare of the inhabitants of Sussex County.

NOW, THEREFORE, THE COUNTY OF SUSSEX HEREBY ORDAINS:

Section 1. That Chapter 115, Article IV, Subsection 115-22, Code of Sussex County, be amended by adding the designation of Conditional Use No. 1977 as it applies to the property hereinafter described.

Section 2. The subject property is described as follows:

ALL that certain tract, piece or parcel of land, lying and being situate in Indian River Hundred, Sussex County, Delaware, and lying northwest corner of Route 30 (Gravel Hill Road) and Horseshoe Drive west of Route 24 (John J. Williams Highway) and being more particularly described as:

BEGINNING at a pipe at the northwest corner of the intersection of Route 30 (Gravel Hill Road) and Horseshoe Drive, and west of Route 24 (John J. Williams Highway); thence north 68°30'23" west 128.30 feet along the northerly right-of-way of Horseshoe Drive to a pipe; thence northerly and easterly along lands, now or formerly, of Walter J. Godwin north 04°14'37" east 34.95 feet to a pipe and north 56°42'37" east 86.00 feet to a pipe on the westerly

right-of-way of Route 30; thence southerly 137.10 feet along the westerly right-of-way of Route 30 to the point and place of beginning. Said parcel containing 8,276 square feet, more or less, per survey by Simpler Surveying & Associate.

This Ordinance shall take effect immediately upon its adoption by majority vote of all members of the County Council of Sussex County, Delaware.

PROPOSED